

NATIONAL VIDEO CORPORATION
 4300 W 47TH STREET CHICAGO 32, ILLINOIS
 CLIFFSIDE 4-5600

The 16BAP4 is a 16"-114° lightweight tube, laminated with a Pittsburgh facepanel and a 4 3/8" neck length. This tube has a 600 milliampere, 6.3 volt filament, a straight gun which requires no ion trap and 50 volt G₂ for cathode drive design.

ELECTRICAL DATA

Focusing Method	Electrostatic
Deflection Angles, Approximate	
Horizontal	103 Degrees
Vertical	87 Degrees
Diagonal	114 Degrees
Direct Interelectrode Capacitances	
Cathode to all other electrodes, approximate	5 uuf
Grid #1 to all other electrodes, approximate	6 uuf
External Conductive Coating to Anode	1500 max. uuf
	1000 min. uuf
Heater Current at 6.3 Volts	600 ± 30ma
Heater Warm-up Time	11 Seconds

OPTICAL DATA

Phosphor number JEDEC designation	P4-Aluminized
Light Transmittance at Center, Approximate	59%

MECHANICAL DATA

Overall Length	10 11/16 ±5/16 Inches
Greatest Diameter of Tube	
Greatest Dimensions of Tube	
Diagonal	15 5/8 ±1/8 Inches
Width	13 23/32 ±1/8 Inches
Height	11 3/32 ±1/8 Inches
Minimum Useful Screen Diameter (Projected)	
Minimum Useful Screen Dimensions (Projected)	
Diagonal	14 7/8 Inches
Horizontal Axis	12 15/16 Inches
Vertical Axis	10 1/4 Inches
Area	125 Sq. Inches
Neck Length	4 3/8 ±1/8 Inches
Bulb EIA designation or equivalent (including shield designation)	J125 A1 A & FP125 A1
Bulb Contact	J1-21
Base	8HR
Basing	B7-208
	JEDEC Designation
	JEDEC Designation
	JEDEC Designation

Bulb Contact Alignment

J1-21 contact aligns with pin position #4 \pm 30 Degrees

RATINGS (Design Maximum System)

Unless otherwise specified, voltage values are positive and measured with respect to Grid #1

Maximum Anode Voltage	18,000 Volts
Minimum Anode Voltage	12,000 Volts
Maximum Grid #4 (Focusing Electrode) Voltage	+1100 -500
Maximum Grid #2 Voltage	60 Volts
Minimum Grid #2 Voltage	25 Volts
Cathode Voltage	
Maximum Negative Value	0 Volts DC
Maximum Negative Peak Value	2 Volts
Maximum Positive Value	100 Volts DC
Maximum Positive Peak Value	150 Volts
Maximum Heater Voltage	6.9 Volts
Minimum Heater Voltage	5.8 Volts
Maximum Heater-Cathode Voltage	
Heater negative with respect to cathode	
During warm-up period not to exceed 15 seconds	450 Volts
After equipment warm-up period	200 Volts
Heater positive with respect to cathode	200 Volts

TYPICAL OPERATING CONDITIONS**CATHODE DRIVE SERVICE**

Unless otherwise specified, all voltage values are positive with respect to Grid #1.

Anode Voltage	15,000 Volts DC
Grid #4 Voltage (Focusing Electrode) (Notes 2 & 3)	250 Volts DC
Grid #2 Voltage	50 Volts DC
Cathode Voltage (Note 1)	35 to 55 Volts DC

MAXIMUM CIRCUIT VALUES

Maximum Grid #1 Circuit Resistance	1.5 Megohms
------------------------------------	-------------

GRAPHS AND DRAWINGS

Tube Outline with essential dimensions and tolerances.

Pin Connections:

Pin 1	Heater	Pin 6	Grid No. 1
Pin 2	Grid No. 1	Pin 7	Cathode
Pin 3	Grid No. 2	Pin 8	Heater
Pin 4	Grid No. 4		

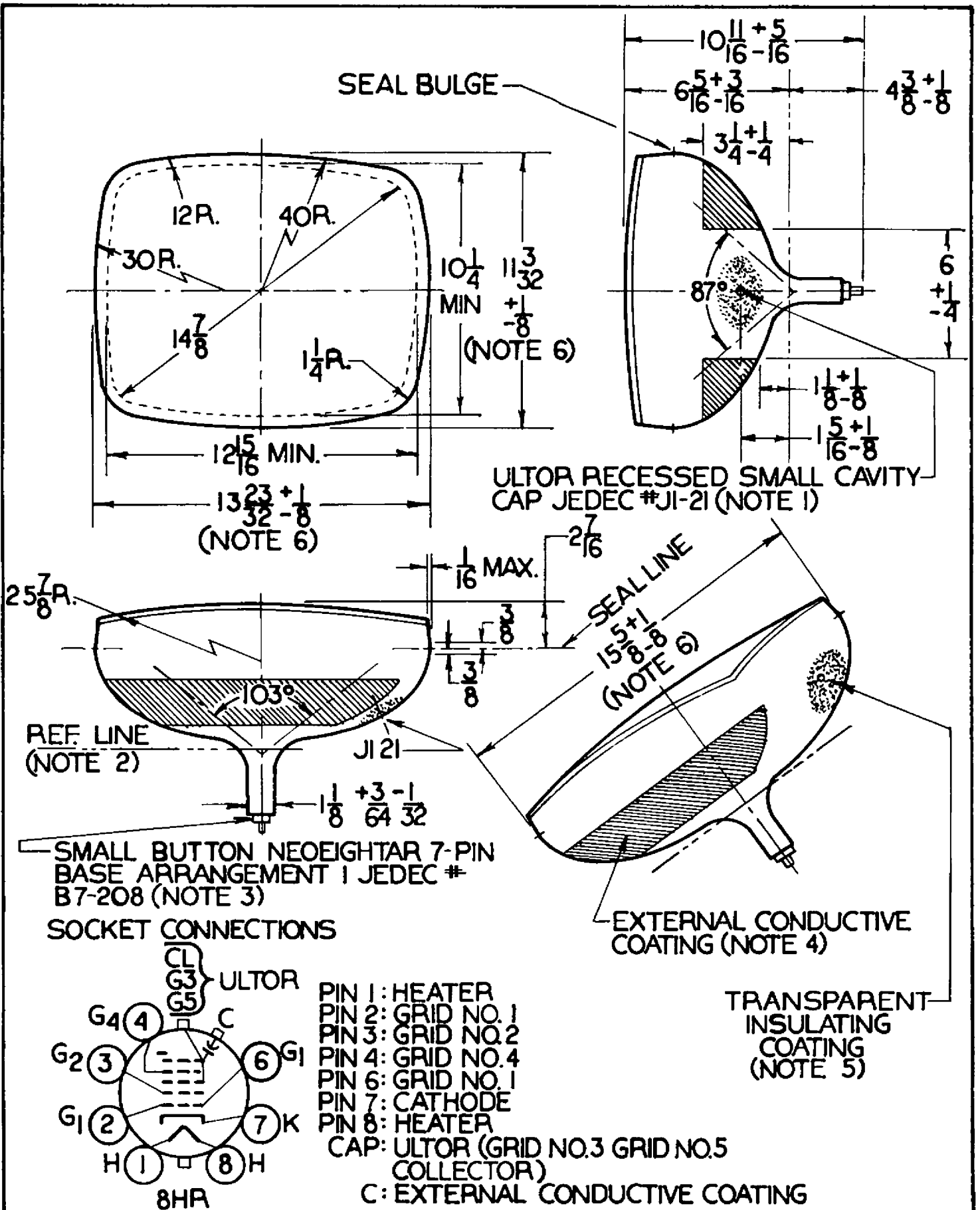

SEAL BULGE

ULTROR RECESSED SMALL CAVITY CAP JEDEC #J1-21 (NOTE 1)

REF. LINE (NOTE 2)

SMALL BUTTON NEOEIGHTAR 7-PIN BASE ARRANGEMENT 1 JEDEC # B7-208 (NOTE 3)

SOCKET CONNECTIONS

EXTERNAL CONDUCTIVE COATING (NOTE 4)

TRANSPARENT INSULATING COATING (NOTE 5)

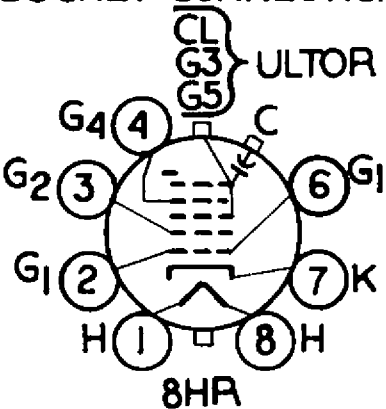

- PIN 1: HEATER
- PIN 2: GRID NO. 1
- PIN 3: GRID NO. 2
- PIN 4: GRID NO. 4
- PIN 6: GRID NO. 1
- PIN 7: CATHODE
- PIN 8: HEATER
- CAP: ULTROR (GRID NO.3 GRID NO.5 COLLECTOR)
- C: EXTERNAL CONDUCTIVE COATING

DRAWN BY A. L. PRIBYL	SCALE 1/8"	EFFECTIVE 2-4-63	DISTRIBUTION	DRAWING NO. 16BAP4
--------------------------	---------------	---------------------	--------------	-----------------------

NOTES:

16BAP4

1. Visual extinction of focused raster.
2. With the combined grid #1 bias voltage and video-signal voltage adjusted to give an anode current of 100 microamperes on a 12 5/16" x 10 1/4" pattern from RCA 2F21 Monoscope or equivalent.
3. Individual tubes will have satisfactory focus at some value between 0 and 400 volts.

NOTES FOR DIMENSIONAL OUTLINE

1. The plane through the tube axis and pin No. 4 may vary from the plane through the tube axis and ultor terminal by angular tolerance (measured about the tube axis) of $\pm 30^\circ$. Ultor terminal is on same side as Pin No. 4.
2. With tube neck inserted through flared end of reference-line gauge JEDEC No. G-126 and with tube seated in gauge, the reference line is determined by the intersection of the plane CC' of the gauge with the glass funnel.
3. Socket for this base should not be rigidly mounted; it should have flexible leads and be allowed to move freely. The design of the socket should be such that the circuit wiring cannot impress lateral strains through the socket contacts on the base pins. Bottom circumference of base wafer will fall within a circle concentric with bulb axis and having a diameter of 1 3/4".
4. External conductive coating must be grounded.
5. To clean this area, wipe only with soft dry lint-less cloth.
6. Measured at the mold-match line.