





## APPLICATION

### MECHANICAL

*Mounting:* The 3CX3000F1 must be mounted vertically with its base up or down at the convenience of the designer. The base is fitted with heavy filament leads to facilitate connections. These leads should be arranged to prevent mechanical stress on the filament structure. The grid is also fitted with a flying lead.

The tube must be protected from severe shock and vibration during shipment and operation.

*Cooling:* Sufficient forced air cooling must be provided to maintain seal temperature at 250°C or below. Air-flow must be started when filament power is applied and it is advisable to continue air-cooling for two minutes after all voltages are removed.

The table below lists minimum air-flow requirements to maintain tube temperatures below 250°C with air flowing in both the base-to-anode and anode-to-base directions. This tabulation presumes air at 50°C and sea level. A separate supply of approximately 3 cubic feet per minute, directed into the filament structure is also required to maintain rated filament seal temperatures. This is best accomplished using a small diameter insulating tubing directed into the stem, between the filament seals.

Plate Dissipation (Watts)	MINIMUM COOLING AIR-FLOW REQUIREMENTS			
	BASE-TO-ANODE FLOW		ANODE-TO-BASE FLOW	
	AIR-FLOW (CFM)	PRESSURE DROP (inches of water)	AIR-FLOW (CFM)	PRESSURE DROP (inches of water)
1000	32	0.49	39	0.65
2000	67.5	1.52	85	2.16
3000	106	3.15	138	4.55

**NOTE:**

An extra 450 watts have been added to these plate dissipation figures in preparing this tabulation, to compensate for grid and filament dissipation.

For operation at high altitudes or higher ambient temperatures, these quantities should be increased. In all cases it is suggested that actual temperatures be measured to insure adequate cooling.

### ELECTRICAL

*Filament:* The rated filament voltage for the 3CX3000F1 is 7.5 volts and should not be exceeded by more than five percent if maximum tube life is to be realized. Reduction of filament voltage to about 7.2 volts will actually enhance tube life and provision should be made for this adjustment where the lower emission can be tolerated.

*Grid Operation:* The grid dissipation rating of the 3CX3000F1 is 50 watts. This is the product of the peak positive grid voltage and average dc grid current. When tubes are used in parallel in amplifier or modulator service, provision should be made for individual adjustment of bias voltage, in order to match the tubes.

*Special Applications:* If it is desired to operate the tube under conditions widely different from those given here, write to Eimac Division of Varian Assoc., 301 Industrial Way, San Carlos, California, for information and recommendations.

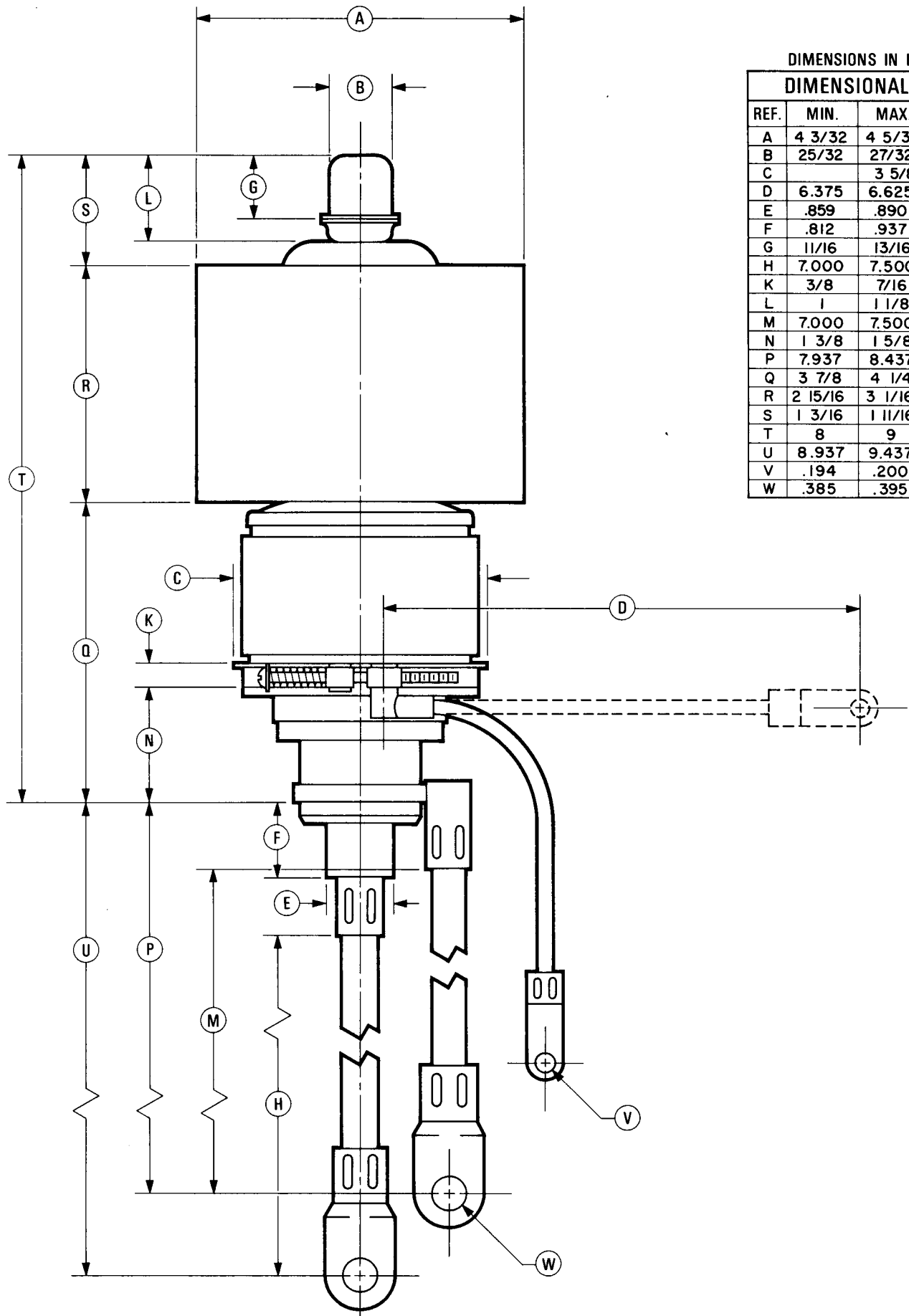

DIMENSIONS IN INCHES

DIMENSIONAL DATA

REF.	MIN.	MAX.	NOM.
A	4 3/32	4 5/32	
B	25/32	27/32	
C		3 5/8	
D	6.375	6.625	
E	.859	.890	
F	.812	.937	
G	11/16	13/16	
H	7.000	7.500	
K	3/8	7/16	
L	1	1 1/8	
M	7.000	7.500	
N	1 3/8	1 5/8	
P	7.937	8.437	
Q	3 7/8	4 1/4	
R	2 15/16	3 1/16	
S	1 3/16	1 11/16	
T	8	9	
U	8.937	9.437	
V	.194	.200	
W	.385	.395	



3CX3000F1

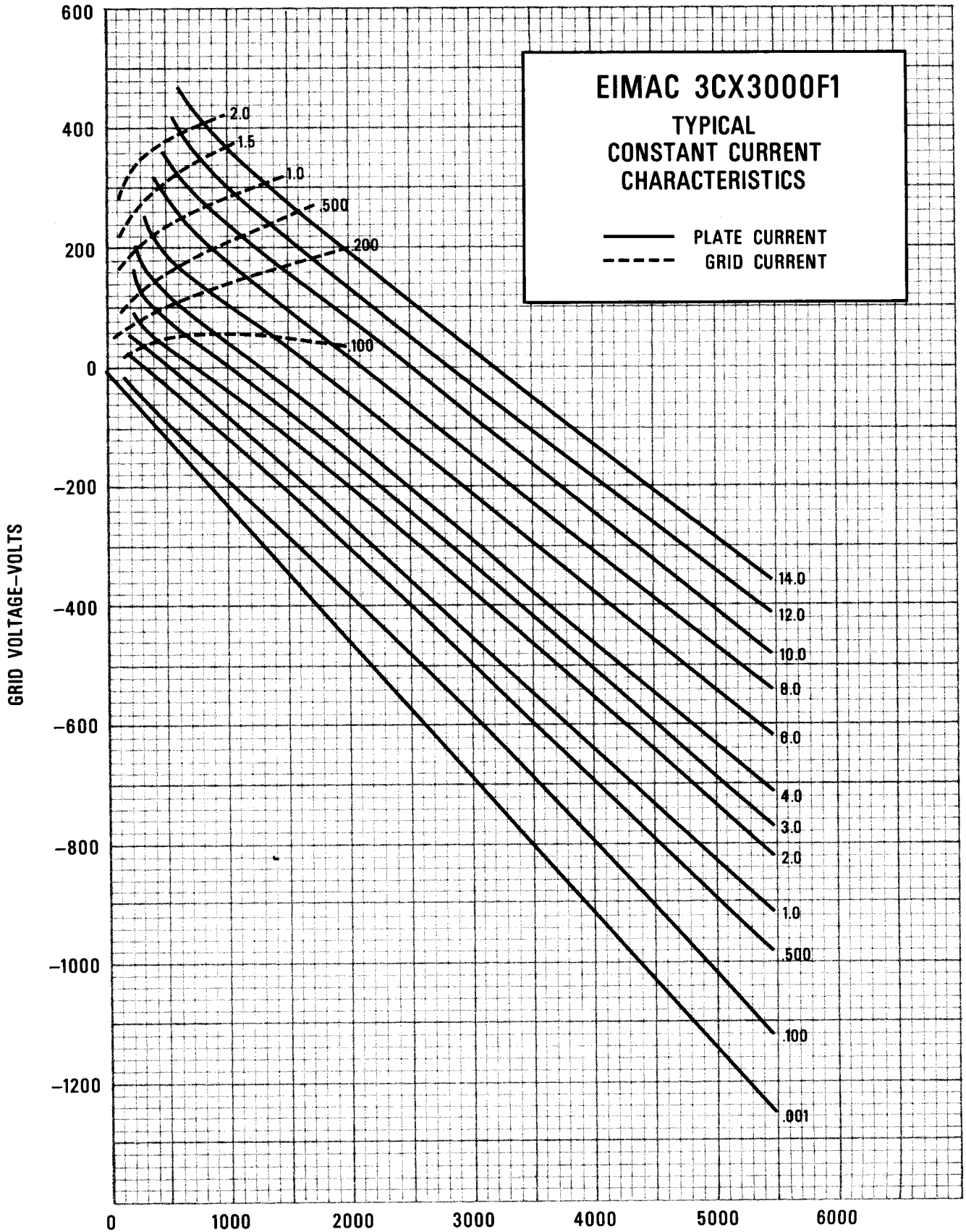

PLATE VOLTAGE-VOLTS

CURVE 3452