

## CHARACTERISTICS

### GENERAL DATA

Focusing Method . . . . .	Electrostatic
Deflection Method . . . . .	Magnetic
Deflection Angles (approx.)	
Horizontal . . . . .	79 Degrees
Diagonal . . . . .	85 Degrees
Phosphor . . . . .	Aluminized P4
Fluorescence . . . . .	White
Persistence . . . . .	Short to Medium
Faceplate . . . . .	Gray Filter Glass
Light Transmittance (approx.) . . . . .	75 Percent

### ELECTRICAL DATA

Heater Voltage . . . . .	6.3 Volts
Heater Current . . . . .	0.6 ±5% Ampere
Heater Warm-up Time <sup>1</sup> . . . . .	11 Seconds
Direct Interelectrode Capacitances (approx.)	
Cathode to All Other Electrodes . . . . .	5 μmf
Grid No. 1 to All Other Electrodes . . . . .	6 μmf
External Conductive Coating to Anode <sup>2</sup> . . . . .	1200 μmf Max. 900 μmf Min.
Ion Trap Magnet . . . . .	External, Single Field Type

### MECHANICAL DATA

Minimum Useful Screen Dimensions (Maximum Assured) . . . . .	12 x 9 <sup>7</sup> / <sub>16</sub> Inches
Minimum Useful Screen Area . . . . .	103 Sq. Inches
Bulb Contact (Recessed Small Cavity Cap) . . . . .	J1-21
Base (Small Shell Duodecal 6-Pin) . . . . .	B6-63
Basing . . . . .	12L

## RATINGS

### MAXIMUM RATINGS (Absolute Maximum Values)

Anode Voltage . . . . .	15,400 Volts dc
Grid No. 4 Voltage (Focusing Electrode) . . . . .	-550 to +1100 Volts dc
Grid No. 2 Voltage . . . . .	550 Volts dc
Grid No. 1 Voltage	
Negative Bias Value . . . . .	154 Volts dc
Negative Peak Value . . . . .	220 Volts
Positive Bias Value . . . . .	0 Volts dc
Positive Peak Value . . . . .	2 Volts
Peak Heater-Cathode Voltage	
Heater Negative with Respect to Cathode	
During Warm-up Period not to Exceed	
15 Seconds . . . . .	450 Volts
After Equipment Warm-up Period . . . . .	200 Volts
Heater Positive with Respect to Cathode . . . . .	200 Volts

### TYPICAL OPERATING CONDITIONS

Anode Voltage . . . . .	12,000 Volts dc
Grid No. 4 Voltage for Focus . . . . .	-48 to +264 Volts dc
Grid No. 2 Voltage . . . . .	300 Volts dc
Grid No. 1 Voltage Required for Cutoff <sup>3</sup> . . . . .	-28 to -72 Volts dc
Ion Trap Magnet Current (Average) <sup>4</sup> . . . . .	26 Ma dc
Field Strength of PM Ion Trap Magnet <sup>5</sup> . . . . .	28 Gaussess Min.

### CIRCUIT VALUES

Grid No. 1 Circuit Resistance . . . . .	1.5 Megohms Max.
---	------------------

### NOTES:

(Continued on Page 2)

1. Heater warm-up time is the time required for the voltage across the heater terminals to increase to 5.0 volts in the JETEC test circuit, with E = 25 volts and series R = 31.5 ohms.

## QUICK REFERENCE DATA

Television Picture Tube  
14" Direct Viewed  
Rectangular Glass Type  
Spherical Faceplate  
Gray Filter Glass  
Magnetic Deflection  
Electrostatic Focus  
Single Field Ion Trap  
External Conductive Coating  
Aluminized Screen

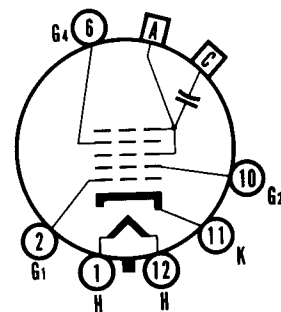
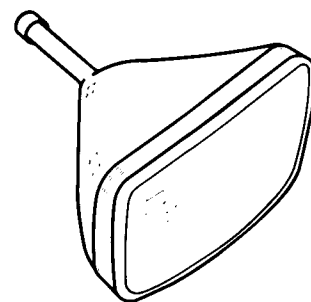

12-1

**SYLVANIA ELECTRIC  
PRODUCTS INC.**

**TELEVISION PICTURE TUBE  
DIVISION**

**SENECA FALLS, NEW YORK**

*Prepared and Released By The  
TECHNICAL PUBLICATIONS SECTION  
EMPORIUM, PENNSYLVANIA*

APRIL 1956

PAGE 1 OF 2

SYLVANIA  
14SP4

PAGE 2

2. External conductive coating must be grounded.
3. Visual extinction of focused raster. Extinction of stationary focused spot will require that these values be about 5 volts more negative.
4. For JETEC Ion Trap Magnet No. 117 with pole pieces centered over Grid No. 2 on mount, and rotated for maximum brightness.
5. For typical PM ion trap magnet with field strength tolerance of  $\pm 3$  gauss.

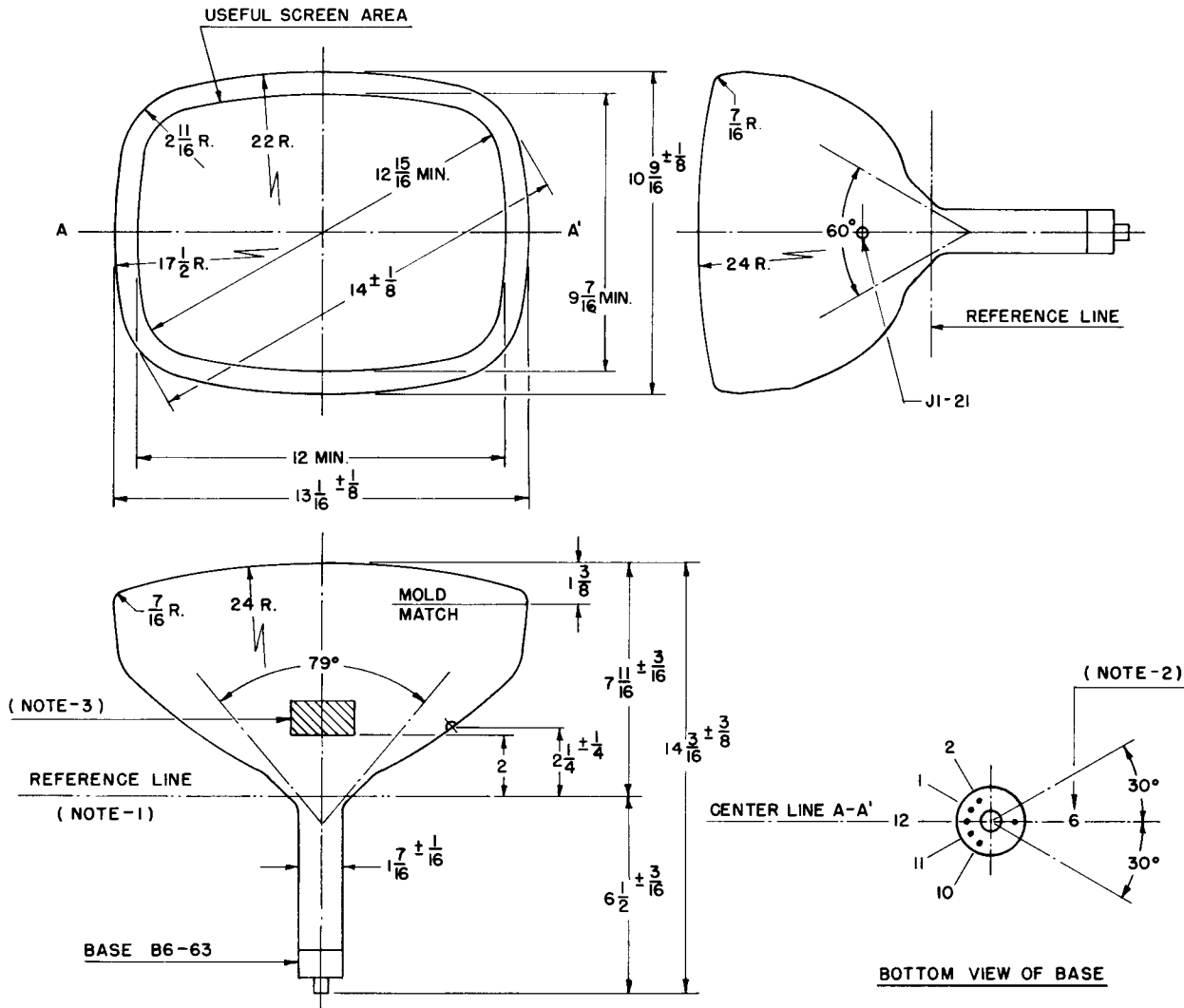

DIAGRAM NOTES:

1. Reference line is determined by the plane C-C' of the reference line gauge (JETEC No. 116) when the gauge is resting on the glass cone.
2. Base pin No. 6 aligns with anode contact terminal J1-21 within 30 degrees.
3. Contact area for external conductive coating, 2" x 2", located 90 degrees counterclockwise from anode contact as viewed from base end of tube.
4. Dimensions are in inches.

WARNING:

X-ray radiation shielding may be necessary to protect against possible danger of personal injury from prolonged exposure at close range if this tube is operated at higher than the manufacturer's Maximum Rated Anode Voltage or 16,000 volts, whichever is less.