

PHILIPS

APPLICATION BOOK

ELECTRONIC COMPONENTS
AND MATERIALS DIVISION

AUDIO AMPLIFIER SYSTEMS

TRANSISTOR CIRCUITS
INTEGRATED CIRCUITS
LOUDSPEAKERS

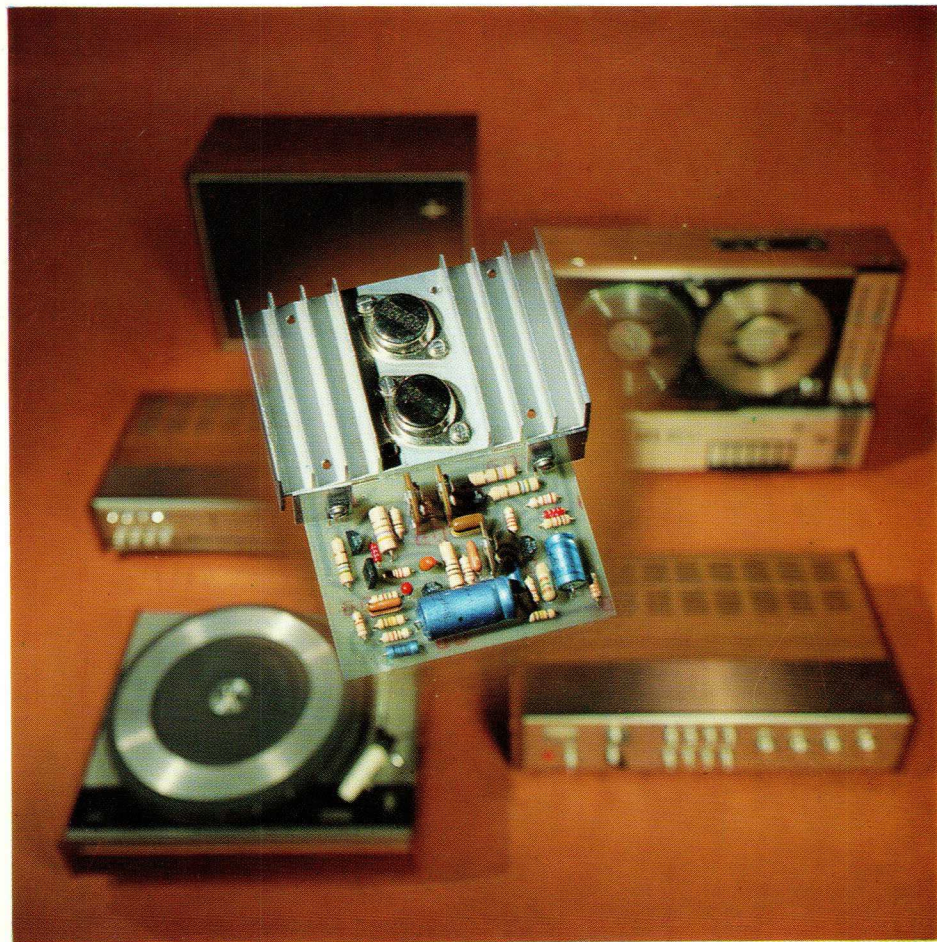

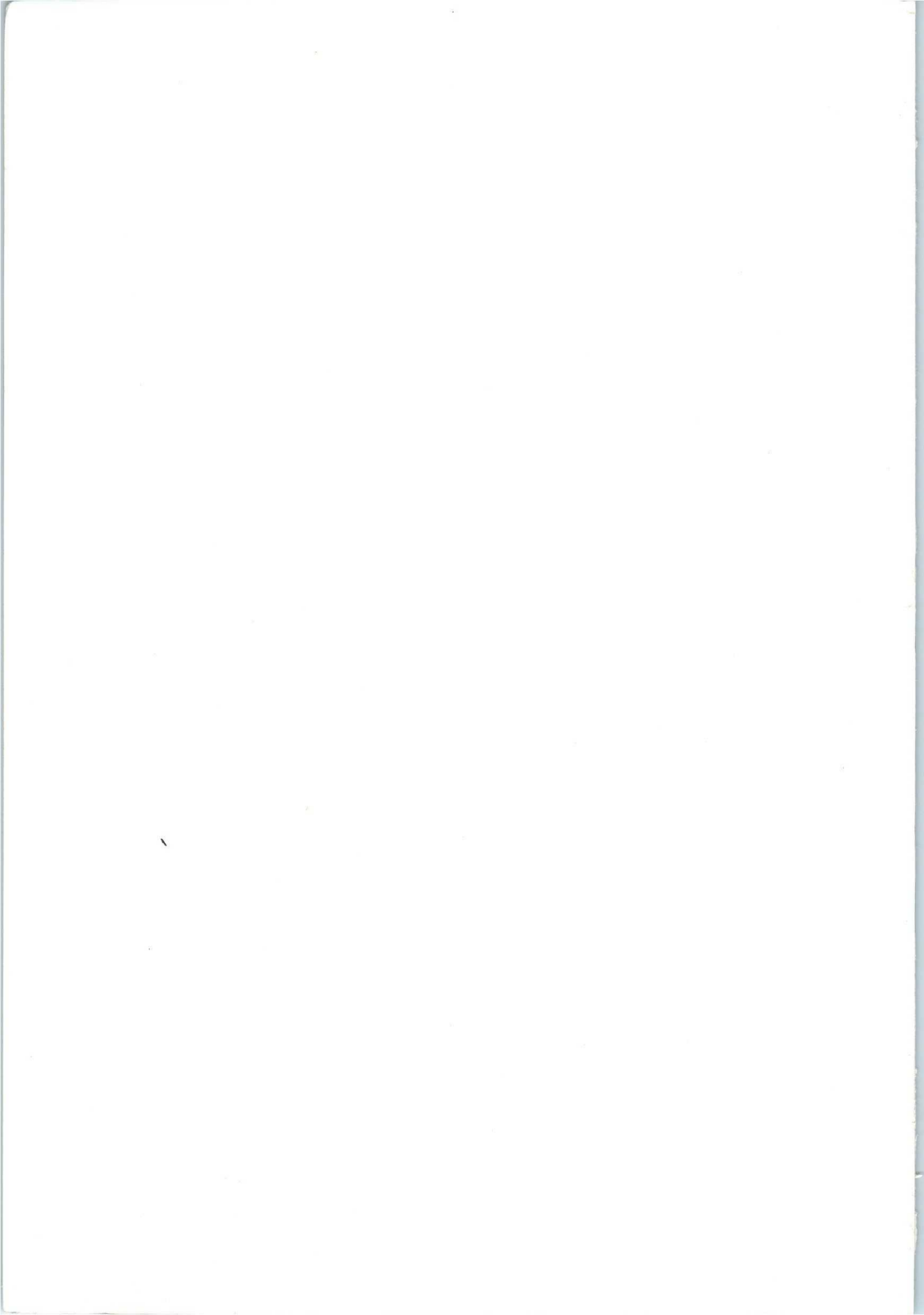

Audio Amplifier Systems

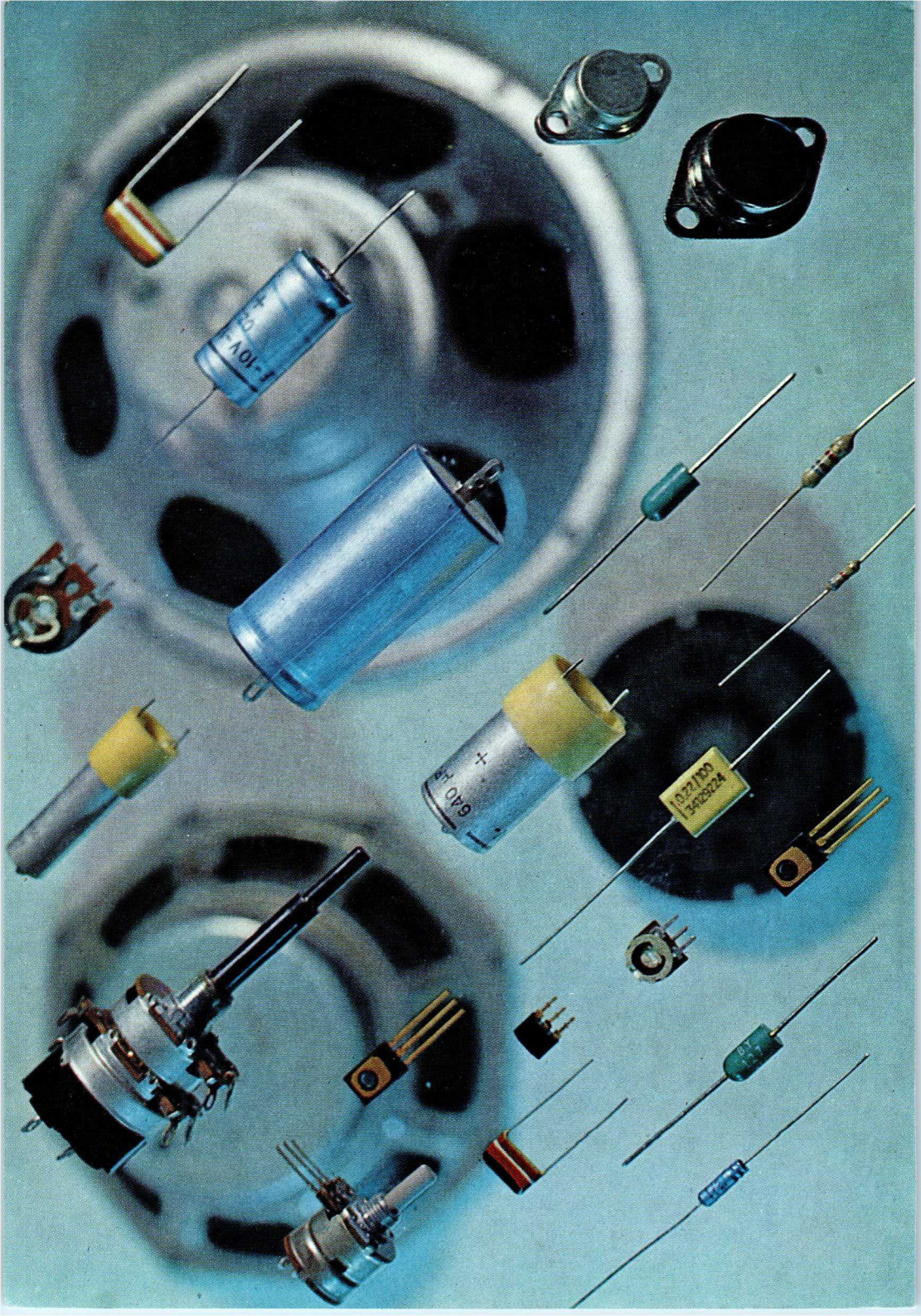

Audio Amplifier Systems

transistor circuits - integrated circuits - loudspeakers

M. D. Hull, C. Eng., A.M.I.E.R.E.

**PUBLICATIONS DEPARTMENT
ELECTRONIC COMPONENTS AND MATERIALS DIVISION**

© *N.V. Philips' Gloeilampenfabrieken*

EINDHOVEN - The Netherlands

September 1970

*The publication of this document does not
imply a licence under any patent*

List of Contents

1	Germanium and Silicon Transistors	1
2	Low-level Audio Amplifiers and Control Circuits.	2
2.1	Design Requirements for Audio Pre-amplifiers	2
2.1.1	Input Facilities and Controls	2
2.1.2	Frequency Bandwidth	7
2.1.3	Signal/Noise Ratio	9
2.1.4	Distortion.	9
2.2	Transistors for Small-signal Applications.	10
2.2.1	Gain Considerations	10
2.2.2	Survey of Transistors	11
2.3	Low-level Amplifier Circuits	15
2.3.1	Circuit 1: Basic A.F. Voltage Amplifier.	15
2.3.2	Circuit 2: Low-distortion, High-output voltage Amplifier	21
2.3.3	Circuit 3: Buffer Amplifier	22
2.3.4	Circuit 4: Microphone Amplifier	24
2.3.5	Circuit 5: Mixer Amplifier	26
2.3.6	Circuit 6: Magnetic Pick-up Pre-amplifier	27
2.3.7	Circuit 7: Pre-amplifier for Pick-up, Tape and Radio Inputs	30
2.3.8	Circuit 8: Universal Pre-amplifier	33
2.4	Control Circuits	43
2.4.1	Circuit 9: Input Switching Arrangements	43
2.4.2	Circuit 10: Stereo Balance Control	45
2.4.3	Circuit 11: Stereo Balance Meter	47
2.4.4	Circuit 12: Active Tone Control	48
2.4.5	Circuit 13: Sound Source Width (Dimension) Control	50
2.4.6	Circuit 14: Low-Pass/High-Pass Filter	52
2.4.7	Circuit 15: Noise and Rumble Filter	53
2.4.8	Circuit 16: Presence Control	55
3	Power Amplifiers	57
3.1	Performance Characteristics	57
3.1.1	General	57
3.1.2	Distortion.	57
3.1.3	Dynamic Range	58
3.1.4	Damping Factor	59
3.1.5	Power Bandwidth	60
3.1.6	Output Power Ratings	60

3.2	Output Stage Arrangements	61
3.2.1	General	61
3.2.2	Principles of Complementary Output Stages	61
3.2.3	Quasi-Complementary Symmetry	65
3.3	Survey of Transistors for Power Amplifiers	65
3.3.1	Transistors for Battery-operated Equipment	65
3.3.2	Silicon Driver and Power Transistors	70
3.4	Practical Layout of Audio Circuitry	70
3.4.1	General Principles	70
3.4.2	Earthing	71
3.4.3	Stray Fields	73
3.4.4	Power Supplies	73
3.5	Economical Transistor Power Amplifiers	74
3.5.1	Circuit 17: One Watt Stereo Pick-up Amplifier	74
3.5.2	Circuit 18: Two Watt Stereo Pick-up/Radio Amplifier	76
3.5.3	Circuit 19: Four Watt Mono Car Radio Amplifier	80
3.5.4	Circuit 20: Five/Ten Watt Low-cost Amplifier	83
3.6	High Fidelity Power Amplifiers	86
3.6.1	Circuit 21: 8 Watt Hi-Fi Amplifier using AD161/162 Output Transistors	86
3.6.2	Circuit 22: 15 Watt Hi-Fi Amplifier using BD181 Output Transistors	90
3.6.3	Circuit 23: 20 Watt Hi-Fi Amplifier using BD181 Output Transistors	97
3.6.4	Circuit 24: 25 Watt Hi-Fi Amplifier using BD182 Output Transistors	100
3.6.5	Circuit 25: 40 Watt Hi-Fi Amplifier using BD182 Output Transistors	119
3.6.6	Circuit 26: Overdrive Indicator for 25 W and 40 W Amplifiers	133
4	Integrated Circuit Amplifiers	135
4.1	Application of Integrated Circuits to Audio Amplifiers	135
4.2	Practical Circuits	136
4.2.1	Circuit 27: One Watt Transformerless Class-B Audio Amplifier for Record Players using the TAA300 Integrated Circuit	136
4.2.2	Circuit 28: Two Watt Pick-up Amplifier using the TAA320 and the high voltage Class-A Transistor BD115	150
4.2.3	Circuit 29: Four Watt Pick-up Amplifier using the TAA320 and two high voltage BD115 Output Transistors.	155
4.2.4	Circuit 30: Four Watt Transformerless Car Radio Amplifier using the TAA435 and AD161/162 Output Transistors	157
4.2.5	Circuit 31: Recording and Playback Amplifier using the TAA310 Integrated Circuit	161

5 Loudspeaker Systems	169
5.1 Principles of Loudspeaker Selection	169
5.1.1 Survey of Loudspeakers	169
5.1.2 Power Requirements	175
5.1.3 Methods of Mounting.	181
5.2 Sealed Enclosures for High Fidelity Systems	182
5.2.1 Principles of Design.	182
5.2.2 Enclosure Volume and Frequency Response	186
Appendix — Heat-sink Design and Calculations	192
Index	197

The circuits described in this book are proven designs and we regret that we cannot undertake to answer queries from home-constructors arising from the information presented.

It should be stressed that the circuits have been constructed using components of our own manufacture throughout. No guarantee can therefore be given that the published results will be obtained if other components are used.

Whilst every care has been taken to ensure the accuracy of the information presented, no liability therefor can be assumed.

Foreword

Sound recording and reproduction became firmly established with the invention of the gramophone in 1887. Ever since then, improvements in the quality of the reproduced sound have taken place. The invention of the electron tube and the moving coil loudspeaker revolutionized not only the quality of the sound but also the shape and size of the equipment. Now another revolution has taken place with the development of solid-state devices. The use of the transistor and integrated circuit in audio equipment has brought about a radical change once again in the appearance of the equipment. Never before have so many watts been packed into so small a volume.

The development of small attractive units, blending subtly with modern décor in the home, has not been entirely without some drawbacks. In harmony with smaller amplifiers there must be smaller loudspeaker enclosures and, to achieve this size reduction without impairing the sound quality, the requirements imposed on the components concerned have become more and more stringent.

For instance, reducing the volume of the speaker enclosure results in a lower efficiency for the same speaker. To obtain the same acoustic output, the electrical power to the loudspeaker system has to be increased. This, in turn, means higher power ratings for the amplifier components and power supply.

To ensure that our components keep abreast of the requirements for modern audio equipment design, our Application Laboratories are engaged in a continuous development programme. A comprehensive range of miniature components is readily available for small-sized equipment, in which transistors play the major role.

There are transistors for every audio application, ranging from low noise to high power, for use in pre-amplifier, power amplifier and tape recorder circuits. To demonstrate the differences in their properties we have selected over 30 circuits representative of general and sophisticated requirements. They cater for a wide range of tastes from the inexpensive and simple design, to the more costly high fidelity circuits.

In addition to the circuits of complete amplifiers, there is a wide range

of circuits for individual stages, such as mixers, tone controls and filters. These are intended to be used in combination with one another, like building bricks, provided that a little discretion is used in their inter-connection. All the designs are for construction on printed-wiring boards.

Five of the amplifiers described use integrated circuits. The great simplicity with which these can be employed makes them an attractive proposition, not only for present-day designs, but for the equipment of tomorrow.

Since an audio amplifier system comprises all the equipment necessary to amplify the electrical signals from the input transducer and produce a replica of the original sound, the loudspeaker forms a vital part of any audio amplifier system. To obtain the best performance from an audio amplifier it is essential that the correct load conditions are applied and we have therefore included information on loudspeakers for use with the amplifiers, together with basic details of the design of sealed enclosures.

Finally, an Appendix on heat-sink design and calculations has been included, since it is most important that adequate provision is made for the dissipation of heat in the power amplifier stages.

M.D.H.

Acknowledgements

Acknowledgements are made to members of the Staff of the Semiconductor Laboratories, particularly W. A. M. Peters, G. W. J. van de Pol, J. J. Sips and J. Thörig, for their valuable assistance. Also to J. Vandekerckhove of the Loudspeaker Development Laboratory for carrying out a large number of measurements on loudspeakers at the author's request.

Some of the information included in this book has been taken from recently published material by Philips Electron Devices, Toronto; Mullard Ltd., London; and Valvo GmbH, Hamburg, to whom thanks are due.

Finally, the author acknowledges the valuable assistance of L. J. M. van Boldrik for many helpful suggestions and without whose tireless enthusiasm this book might never have been written.

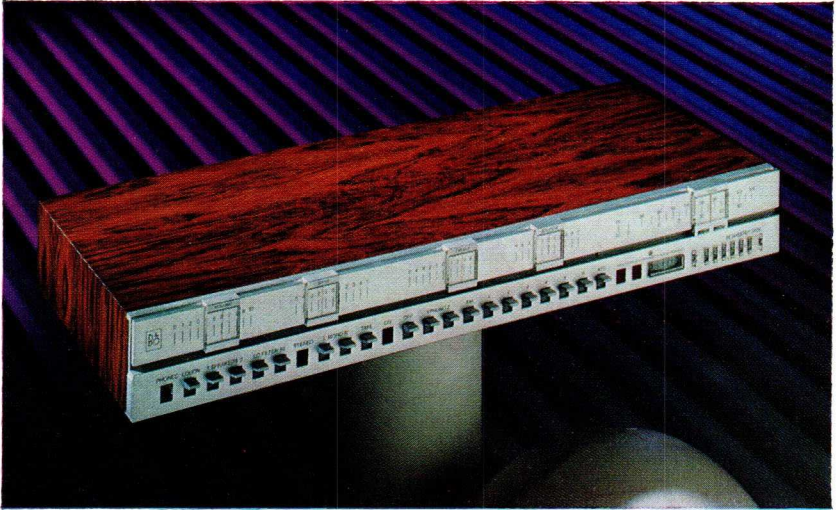

The BEOMASTER 3000 shown here is an elegant example of a high-fidelity stereo tuner-amplifier, which uses small-signal transistors mentioned in Chapter 2. (By courtesy of Bang & Olufsen A/S, Denmark.)

1 Germanium and Silicon Transistors

Nearly all transistors are made from either silicon or germanium. In the past germanium was much easier to refine than silicon and, since silicon presented many manufacturing problems, the early transistors were made from germanium. The problems with silicon have largely been overcome by the development of the planar process and both silicon and germanium transistors are now produced concurrently. There are applications for which each is the more suitable.

The operating junction temperature of germanium transistors is limited to about 100 °C, whereas silicon devices can operate at temperatures in excess of 175 °C. However, germanium transistors still have the advantage of low values of forward base/emitter voltage and knee voltage and, since these represent voltage losses in the circuit, germanium devices are particularly suitable for the lower-voltage type of audio output stage.

The leakage currents of silicon transistors are far smaller than those of germanium transistors due to the extremely high intrinsic resistivity of silicon ($3 \times 10^5 \Omega \text{ cm}$ at 27 °C) compared with germanium (47 $\Omega \text{ cm}$ at 27 °C). This advantage, combined with higher permissible junction temperatures and high voltage ratings of silicon transistors, makes them ideal for a wide variety of audio applications, especially at high output powers where high voltages are necessary.

The advantages of using either silicon or germanium transistors for specific applications are discussed for low-level audio amplifiers in Chapter 2, and for power amplifiers, including portable equipment, in Chapter 3.

2 Low-level Audio Amplifiers and Control Circuits

2.1 Design Requirements for Audio Pre-amplifiers

2.1.1 INPUT FACILITIES AND CONTROLS

For the listener the most common source of programme material is undoubtedly the radio, followed by disc and tape in that order. The microphone is normally used only in connection with a tape recorder, apart from public address applications.

Radio tuners, specially designed to feed a low-level audio signal to high quality amplifiers are now becoming popular. Tuner outputs vary, but it is normal to expect a signal level of between 150 mV and 250 mV. Provision of an input to accept a tuner signal is therefore desirable and this input should have a high impedance normally from 100 k Ω to 500 k Ω .

Crystal pick-ups working directly into a pre-amplifier require a high input impedance, otherwise there will be considerable loss of bass. Since they may produce as much as 1 V output, provision to handle this signal has to be made at the pre-amplifier input, and extra precautions must be taken to prevent damage to the input transistor if the pick-up cartridge is dropped on the record, when a voltage of the order of 100 V may be generated. An input impedance of the order of 0.5 to 1 M Ω would be considered normal for crystal pick-up inputs and a pre-amplifier would be designed to accept, a signal level from about 250 mV.

Magnetic pick-ups, very suitable for high fidelity applications, have a lower voltage output than crystal pick-ups and consequently a high gain amplifier including frequency correction is essential. Assuming that the pre-amplifier unit must deliver 300 mV to fully drive the power output stages, a gain of around 100 would be required, since an output voltage of only 3 mV could be expected from the pick-up. This leads to complications in the design of the pre-amplifier and precautions have to be taken to prevent feedback and instability. Care must be taken to avoid hum pick-up, and earth loops should be kept as small as possible. An input impedance of around 50 k Ω is required for a magnetic pick-up.

For the reproduction of disc recordings the pre-amplifier circuit should provide facilities for equalization of the recording characteristic. Practically all present-day domestic disc recordings are in accordance with the R.I.A.A. characteristic but, to enable older recordings to be played, a switch providing a choice of equalization characteristics is sometimes

used. Table 2.1 gives details of some of the recording characteristics in past and present use. An example of a pre-amplifier offering a choice of disc equalization characteristics is given in Circuit 6.

In addition to disc records, facilities for tape replay are often required. Tape recorded outputs are of two kinds: a high-level pre-corrected output of the order of 250 mV, or a low-level output direct from a playback head. The low-level output may be of the order of 300 to 500 μ V and will

Table 2.1. Past and Present Disc Recording Characteristics.

frequency (Hz)	early Decca		H.M.V.	American		BSI, AES, RIAA IEC	
	78	33	78	45	N.A.B.	78	33/45
20	-18		-15			-15.5	-18.6
30						-14.8	-17.8
50	-11	-14	-12	-26	-16	-14.0	-17.0
60						-13.1	-16.1
70						-12.3	-15.3
80	-7	-13	-8		-15	-11.6	-14.5
100	-5	-12	-7	-18	-8.75	-10.2	-13.1
150						-7.6	-10.2
200				-11		-5.8	-8.3
400	0		0			-2.3	-3.8
500	0	-3	0	-2.5	-1.75	-1.5	-2.6
700	0	0	0	-1		-0.7	-1.2
1000	0	0	0	+1	+1.3	0	0
1500	0					+0.7	+1.4
2000	0	+2	0	+3	+4.2	+1.4	+2.6
3000	0	+4		+6		+2.8	+4.7
4000	+1	+6	0		+8.5	+4.2	+6.6
5000	+2	+6	0	+9	+10.2	+5.5	+8.2
6000	+3.5					+6.7	+9.6
7000		+9	0	+11.5	+13	+7.7	+10.7
8000			0			+8.7	+11.9
10000	+6	+11.5	0	+11.5	+16	+10.5	+13.7
12000						+11.9	+15.3
14000						+13.2	+16.6
16000						+14.3	+17.7
18000						+15.3	+18.7
20000						+16.2	+19.6

depend, amongst other things, on the tape speed. An input impedance of the order of 10 k Ω would be normal for an input direct from a magnetic head.

Microphone inputs are not very common unless public address applications arise. The crystal microphone works under similar conditions to the crystal pick-up, but it has a frequency response incomparable to the dynamic microphone which is favoured for high fidelity work. The dynamic microphone, like the magnetic pick-up, produces only a low signal voltage of the order of 3 to 4 mV, and requires an amplifier input impedance of between say, 20 k Ω and 50 k Ω .

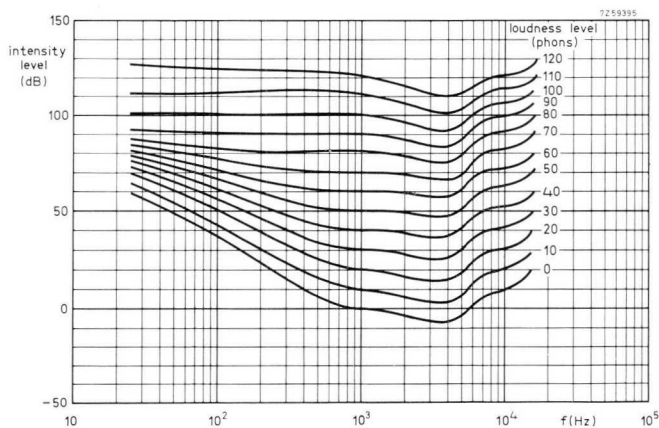

Fig. 2.1. Fletcher-Munson equal-loudness contours.

To avoid interaction between the various signal inputs it is desirable that inputs not in use are shorted to earth. An input selector switch which also performs this earthing function is therefore a useful facility.

Other facilities which must be provided in addition to the input selector, are the volume and tone controls. From 10 dB to 20 dB boost and cut of both bass and treble is normally provided, but values much in excess of that are seldom required since the basic use of the controls is to correct the reproduced sound image, not distort it further. Where stereo applications are considered, a balance control is also usually fitted to achieve aural equality of both channels in the listening room.

Fig. 2.1 shows the Fletcher-Munson equal-loudness contours. The effec-

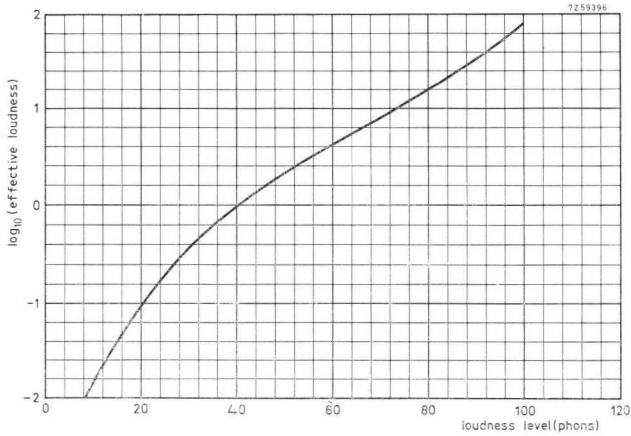

Fig. 2.2. Effective loudness as a function of loudness level.

tive loudness is substantially logarithmic above about 40 phons and semi-logarithmic below that level. Fig. 2.2 shows how the effective loudness is related to the loudness level. By taking the loudness at various frequencies for a given intensity from Fig. 2.1 and correcting for the modified logarithmic response of the ear, as shown in Fig. 2.2, a curve can be plotted showing the relative effective loudness as a function of frequency. Fig. 2.3 shows the result and clearly illustrates how a reduction in volume causes a considerable drop in bass.

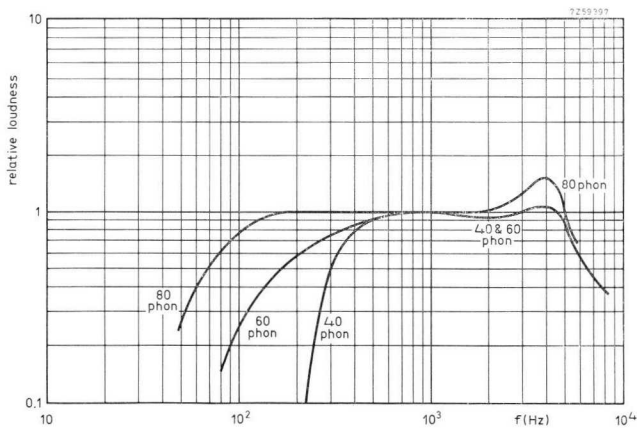

Fig. 2.3. Response of the ear as a function of loudness level.

At low volume levels, therefore, realistic sound reproduction requires bass boosting and to avoid the listener having to reset the bass control each time the volume is adjusted, a physiological volume control is sometimes used. This automatically increases the bass at low volume levels to make up for the insensitivity of the ear in that part of the spectrum and, because it follows the Fletcher-Munson contours, it is sometimes known as a contour control. The attenuation curves of a typical contour control are shown in Fig. 2.4.

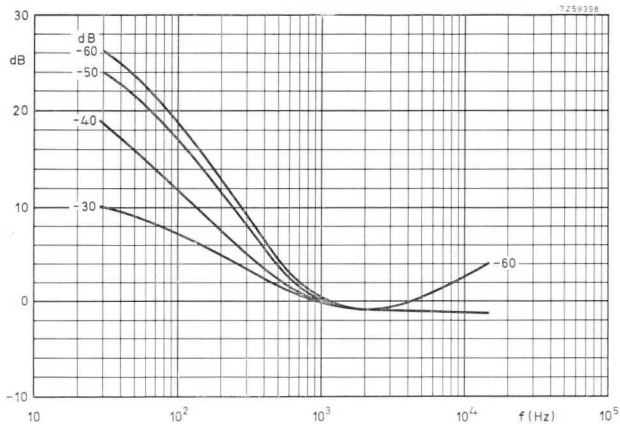

Fig. 2.4. Frequency characteristic of a physiological volume control (contour control).

Artificially boosting the mid-range at a selected frequency between 2000 and 3000 Hz produces the effect of bringing the vocalist or musical instrument nearer to the listener, and is known as *presence*. It is also a valuable facility for correcting mid-range absorption in imperfect listening conditions. A presence control is sometimes fitted on amplifiers and gives a lift of around 6 dB at a selected frequency, normally between 2000 and 3000 Hz. Fig. 2.5 shows a typical modified frequency response.

Some stereo installations have a sound source width (or dimension) control. This is a continuously variable control which at one end of its travel provides 100% in-phase cross-talk between channels and results in mono. The sound source then appears mid-way between the speakers, provided both speakers are in phase and assuming accurate balancing. When the control is turned in the opposite direction anti-

phase cross-talk up to about 20 % can be introduced, the two channels becoming further and further separated as the control is advanced. At about 24 % cross-talk the sound picture breaks up and becomes unpleasant. The apparent width of the “sound stage” can thus be varied with this control.

Finally, a number of useful filters may be employed. Rumble and scratch filters can be used to make up for the deficiencies of turn-tables and discs respectively, the incorporation of a scratch filter having the additional advantage that it may be used to remove the noise from radio tuner signals. For greater refinement low-pass and high-pass filters may be incorporated in the reproduction chain. The variable cross-over types normally provide a selection of frequencies at which roll-off commences and a fixed rate of attenuation is maintained; the variable slope filters, on the other hand, start to roll off at fixed frequencies and the rate of attenuation can be varied in steps. An example of a variable cross-over filter having an attenuation of 8 dB/octave is given in Circuit 14.

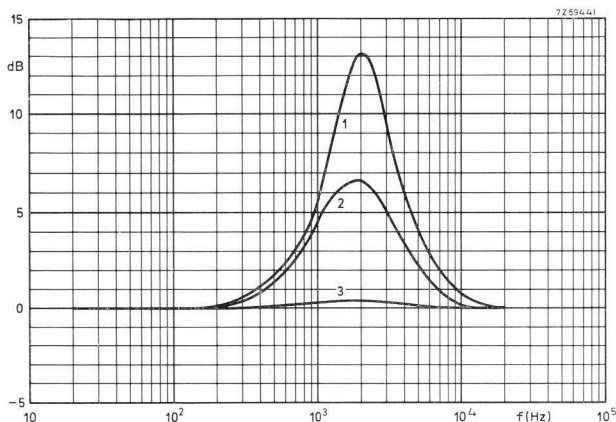

Fig. 2.5. Amplitude/frequency characteristic of a presence control.
Curve 1: maximum; Curve 2: half; Curve 3: minimum.

2.1.2 FREQUENCY BANDWIDTH

Fig. 2.6 shows the frequency range of a number of musical instruments. But to limit the frequency bandwidth of an amplifier to pass only those

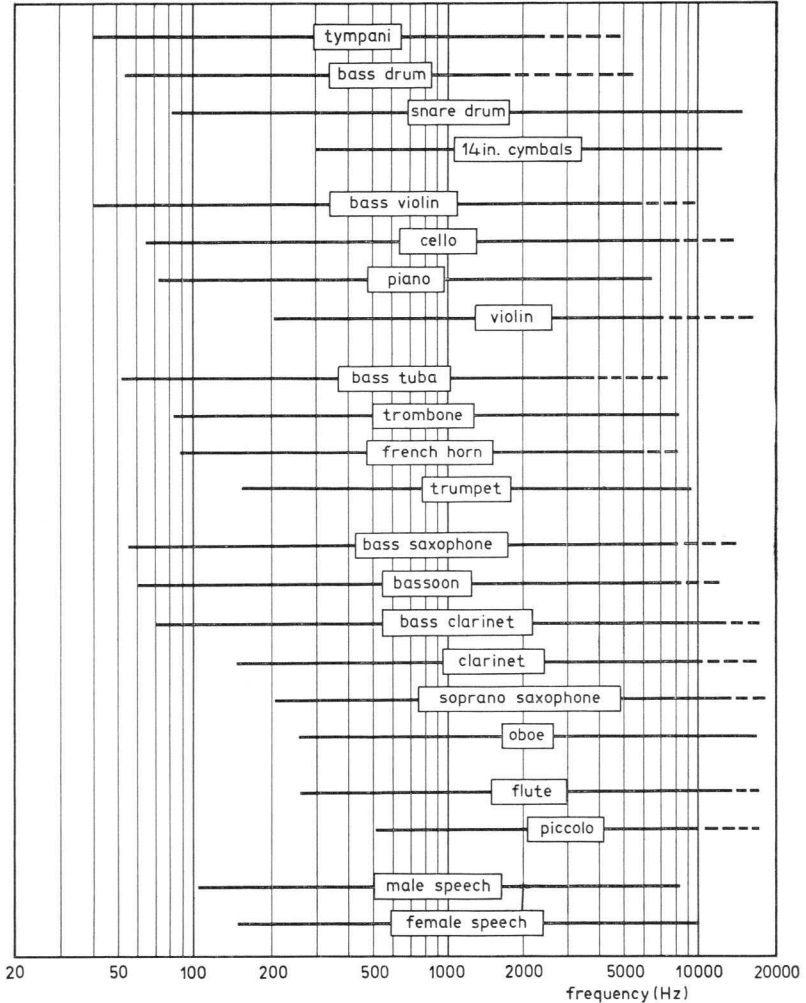

Fig. 2.6. Frequency ranges of musical instruments.

frequencies is neither desirable, nor necessary. The transient handling capabilities of an amplifier are directly related to its bandwidth, since a step-function waveform is rich in high order harmonics. Many high fidelity amplifiers have bandwidths (-1 dB relative to the response at 1000 Hz) of from 15 Hz to well over 30 000 Hz.

2.1.3 SIGNAL/NOISE RATIO

Thermal noise arises in any resistive component which is not at absolute zero temperature. The frequency spectrum of this thermal noise is infinite. When the term signal/noise ratio is applied to sound reproduction, the noise components in each part of the spectrum do not all sound equally loud as shown in Fig. 2.1. Noise is measured via a network which has a frequency response approximately the inverse of the Fletcher-Munson contours, usually the 70 phon curve, and the signal/noise ratio determined in this way is known as the *weighted* signal/noise ratio. Hum components may also be lumped with the noise and the difference between the weighted and unweighted signal/noise ratios will be even more noticeable, since the weighting reduces the hum component by about 10 dB.

It is suggested that a signal/noise ratio of 70 dB would be acceptable to a very critical listener in a very quiet room. Modern transistors, and especially carbon film resistors, used in the low-level input circuits make possible the achievement of signal/noise ratios even better than this. For example, the unweighted signal/noise ratio of the Universal Pre-amplifier in Circuit 8 is > 90 dB on the magnetic pick-up input position. The excellence of the signal/noise ratio will be apparent when it is realised that the frequency bandwidth of this pre-amplifier is from 10 Hz to 35000 Hz, within 1 dB of the 1000 Hz response.

2.1.4 DISTORTION

Distortion in all its forms should be as low as possible. It has been suggested that harmonic distortion below 1 % is undetectable by the ear, but with modern semiconductors entailing transformerless configurations it is fairly easy to arrange for the harmonic distortion to be only 0.1%. What is probably more important is the level of the intermodulation products arising from non-linearity. A very small percentage of intermodulation products can be easily detected by the ear and this objectionable form of distortion occurs mainly in the output stage. This is dealt with in greater detail under Power Amplifiers in Chapter 3.

It is particularly important that distortion arising in the input stages is kept very low. Further amplification will soon raise the level of any distortion beyond an acceptable limit. High-gain low-noise transistors may be used in input stages, with heavy negative feedback to obtain linear operating conditions.

2.2 Transistors for Small-signal Applications

2.2.1 GAIN CONSIDERATIONS

At the working point the parameters of the transistors, i.e. gain, leakage current, etc., have definite values under specified conditions. Temperature is one of these conditions and it can cause a shift in the working point. To prevent a shift occurring it is necessary to stabilize the values of direct current representing the working point and in the case of germanium transistors it is usual to consider the circuit configuration of Fig. 2.7, where conventional voltage biasing is shown. The effect of leakage current on the stage gain under these conditions will now be considered.

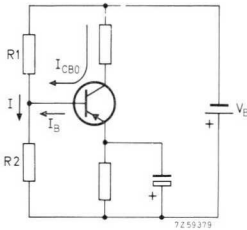

Fig. 2.7. Conventional voltage-biased transistor.

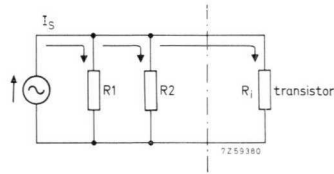

Fig. 2.8. Equivalent circuit of voltage-biased transistor.

The current I flowing through resistors R_1 and R_2 is made much larger (e.g. 10 times greater than the sum of the base current I_B and the leakage current I_{CBO}). The bleeder current is determined by the supply voltage V_B divided by the sum of the bleeder resistors, $R_1 + R_2$. Since the leakage current of germanium transistors is of the order of 10 to 60 μA at $T_{amb} = 45^\circ\text{C}$, the resistance values of R_1 and R_2 will be low.

Assuming that the internal resistance of the battery can be neglected, compared with the resistance values of R_1 and R_2 , Fig. 2.7 may be redrawn as shown in Fig. 2.8 with the bleeder resistors in parallel with each other. Their effective resistance is therefore very low and this, in turn, shunts the input resistance of the transistor. At a normal d.c. current of about 1 mA the input resistance of the transistor is *also* low. Therefore only a part of the total current I_S flows into the transistor. In

other words, the stage gain is affected. The gain could be much higher if the leakage current I_{CBO} was less.

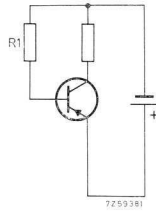

Fig. 2.9. Conventional current-biased transistor.

Silicon planar transistors, such as the BC149 and BC159, have negligible leakage current — just a few pico-amperes ($1 \text{ pA} = 10^{-3} \text{ nA} = 10^{-6} \text{ } \mu\text{A}$), and if silicon transistors are substituted for the germanium transistors that have been hitherto considered, the bleeder resistors R_1 and R_2 can have high values and the stage gain will be increased considerably.

The thermal stabilization of the stage can be simplified, however, since with a small gain (h_{fe}) spread it is possible to use current biasing as shown in Fig. 2.9. Two resistors and one capacitor are omitted and a very high gain is achieved. For small-signal applications, therefore, silicon transistors are preferred.

2.2.2 SURVEY OF TRANSISTORS FOR SMALL-SIGNAL APPLICATIONS

The availability of more or less identical transistors in both n-p-n and p-n-p versions affords the widest possible flexibility in circuit design to meet the requirements of direct-coupled stages, phase-splitting circuits, etc. However, in order to reduce the number of transistors and so simplify the designer's task, the properties of the transistors for different circuit functions have been combined and a small transistor range having wide application has been achieved. This range covers not only the low-noise input stage requirements of tape recorders and high fidelity amplifiers, but also the requirements of all the intermediate stages before the driver stage. The main characteristics of the transistors are given in Tables 2.2 and 2.3.

Table 2.2. N-P-N Transistors for Small-signal Applications.

envelope		V_{CES} (V)	V_{CEO} (V)	I_{CM} (A)	h_{fe}	F_{typ} (dB)
TO-18 ¹⁾	Lock-fit ²⁾					
BC107(A,B) ³⁾	BC147(A,B) ⁴⁾	50	45	0.2	125-500	2
BC108(A,B,C)	BC148(A,B,C)	30	20	0.2	125-900	2
BC109(B,C)	BC149(B,C)	30	20	0.2	240-900	1.2

Table 2.3. P-N-P Transistors for Small-signal Applications.

envelope		$V_{CEX}^{7)}$ (V)	V_{CEO} (V)	I_{CM} (A)	h_{fe}	F_{typ} (dB)
TO-18 ¹⁾	Lock-fit ²⁾					
BC177 ⁵⁾	BC157 ⁶⁾	50	45	0.2	75-260	2
BC178(A,B)	BC158(A,B)	30	25	0.2	75-500	2
BC179(A,B)	BC159(A,B)	25	20	0.2	125-500	1

1) T_j max = 175 °C, $R_{th j-a}$ = 500 °C/W

2) T_j max = 125 °C, $R_{th j-a}$ = 400 °C/W

3) I_{CBO} < 15 μ A at V_{CB} = 20 V and T_j = 150 °C.

4) I_{CBO} < 5 μ A at V_{CB} = 20 V and T_j = 125 °C.

5) $-I_{CBO}$ < 10 μ A at $-V_{CB}$ = 20 V and T_j = 150 °C.

6) $-I_{CBO}$ < 4 μ A at $-V_{CB}$ = 20 V and T_j = 125 °C.

7) V_{BE} = 1 V

In the above Tables the letters A, B and C in brackets indicate the gain spread where T_j = 25 °C, I_C = 2 mA, V_{CE} = 5 V and f = 1 kHz, as follows: A = 125-260, B = 240-500, C = 450-900. The transistors to which these letters apply may be ordered with an A, B or C only.

The noise values given in the Tables do not sufficiently emphasize the outstanding qualities of the transistors listed. Transistor noise depends on the current and voltage settings, the source resistance and the frequency. Fig. 2.10 shows how the noise figure F varies with frequency. The low-noise wide-band transistors BC109/149 and BC159/179 feature *stable* low noise even at very low frequencies, as can be seen. Figs. 2.11 and 2.12 show the constant noise contours for the BC159 transistor at two frequencies, 1 kHz and 10 kHz, the source resistance and the current setting varying.

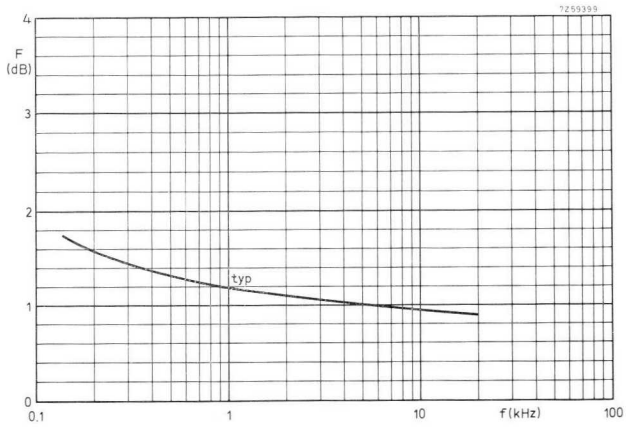

(a) *BC109 and BC149*

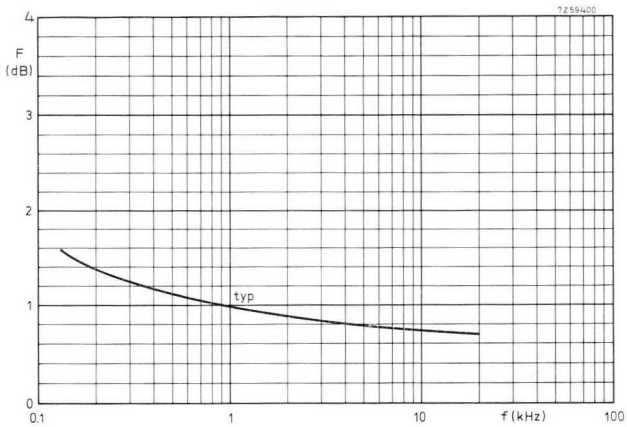

(b) *BC159 and BC179*

Fig. 2.10. Noise figures of the BC109|149 and BC159|179 transistors at $I_C = 0.2 \text{ mA}$, $V_{CE} = 5 \text{ V}$, $B = 200 \text{ Hz}$ and $T_j = 25^\circ \text{C}$.

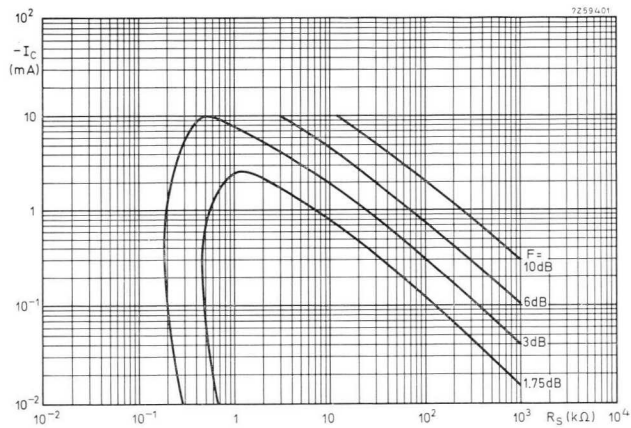

Fig. 2.11. Constant noise contours of the BC159 transistor at 1 kHz, the source resistance and current setting varying.

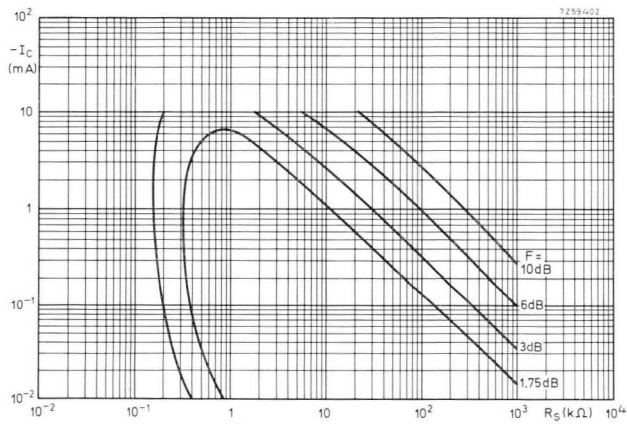

Fig. 2.12. Constant noise contours of the BC159 transistor at 10 kHz, the source resistance and current setting varying.

2.3 Low-level Amplifier Circuits

In the low-level amplifiers and control circuits which follow, all have a high input impedance and a low output impedance and, with one exception, a uniform supply voltage has been used, a value of 18 volts being chosen. The circuits can, therefore, be connected together in any order. A variation of $\pm 15\%$ in the supply voltage is possible without any appreciable change in the performance of the circuits.

2.3.1 CIRCUIT 1 - BASIC A.F. VOLTAGE AMPLIFIER

Four amplifiers are described in this Section. They are derived from the basic voltage amplifier shown in Fig. 2.13. Two d.c. feedback loops

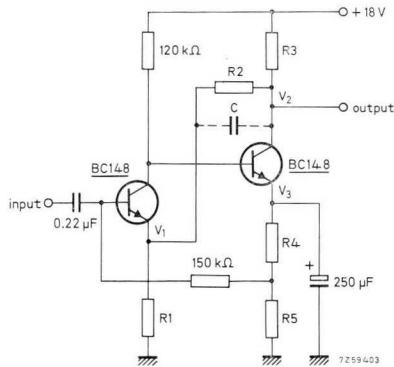

Fig. 2.13. Basic a.f. voltage amplifier. See Table 2.4 for component values.

Table 2.4. Component Values for Basic Amplifier for different Voltage Gains

circuit reference	gain 10 dB	gain 20 dB	gain 30 dB	gain 40 dB
R1	4.7 k Ω	1.5 k Ω	1.5 k Ω	1 k Ω
R2	12 k Ω	15 k Ω	56 k Ω	180 k Ω
R3	1.8 k Ω	2.2 k Ω	2.2 k Ω	2.2 k Ω
R4	470 Ω	560 Ω	330 Ω	680 Ω
R5	1.2 k Ω	470 Ω	270 Ω	220 Ω
C	—	—	—	10 pF

to achieve stabilization against temperature variations are used: one from the emitter of the second transistor to the base of the first, and the other from the collector of the second transistor to the emitter of the first. The component values for circuits with voltage gains of 10, 20, 30 and 40 dB are given in Table 2.4. The voltages at three points in the circuit, together with the input and output impedances Z_{in} and Z_{out} , are given in Table 2.5.

Table 2.5. Voltages and Impedances for Basic Amplifier

voltage or impedance	gain 10 dB	gain 20 dB	gain 30 dB	gain 40 dB
$V1$	3.4 V	0.97 V	0.4 V	0.15 V
$V2$	10.8 V	9.3 V	9.3 V	9.7 V
$V3$	5.6 V	3.55 V	2.3 V	3.4 V
Z_{in}	145 k Ω	140 k Ω	135 k Ω	110 k Ω
Z_{out}	63 Ω	140 Ω	260 Ω	700 Ω

Figs. 2.14 to 2.17 show for the four circuits the total distortion as a function of the output voltage at three frequencies: 40 Hz, 1000 Hz and 12 500 Hz, and the noise voltage at the output as a function of the generator resistance at the input. The total distortion for all four amplifiers remains below 0.1 % for output voltages up to 1 V at 1000 Hz, and below 1 % for output voltages up to 3 V. The noise voltage referred to the input in all four amplifiers is less than 1 μ V. The frequency response (-3 dB points) of all amplifiers is from < 20 Hz to $> 20\,000$ Hz.

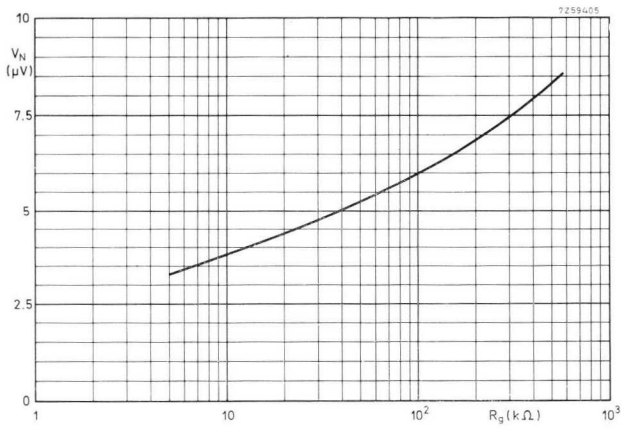
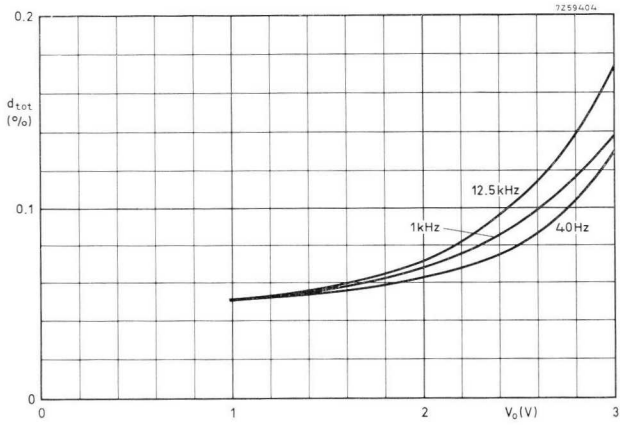

Fig. 2.14. Total distortion and noise voltage at output of 10 dB amplifier.

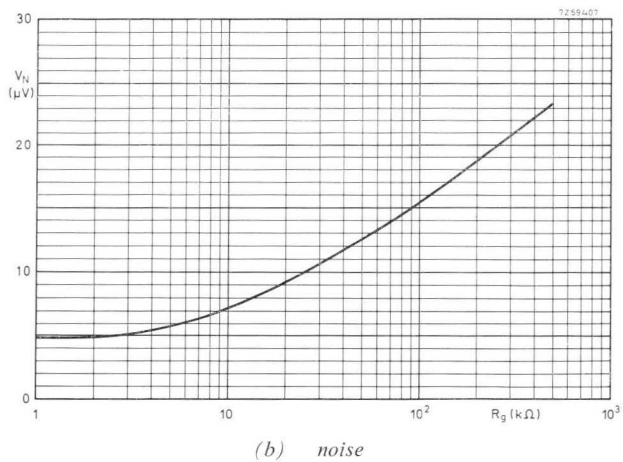
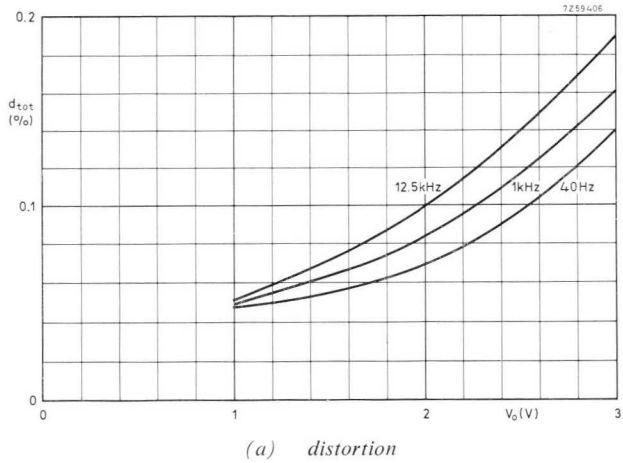

Fig. 2.15. Total distortion and noise voltage at output of 20 dB amplifier.

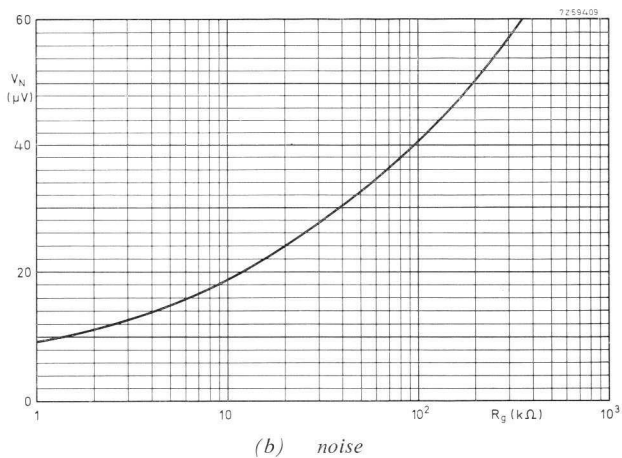
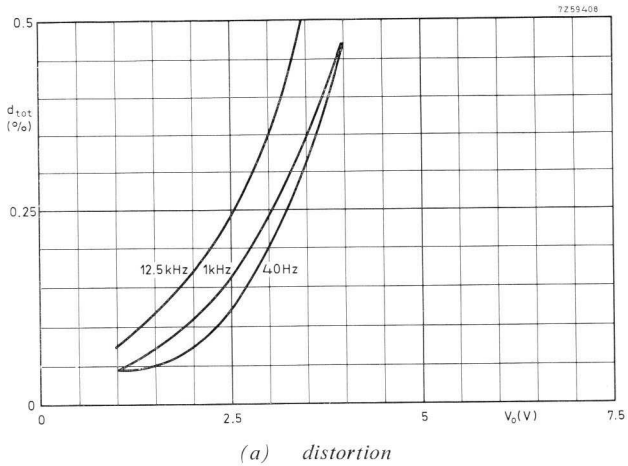
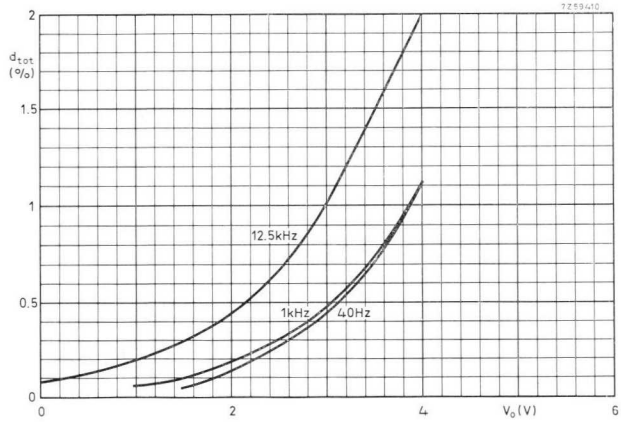
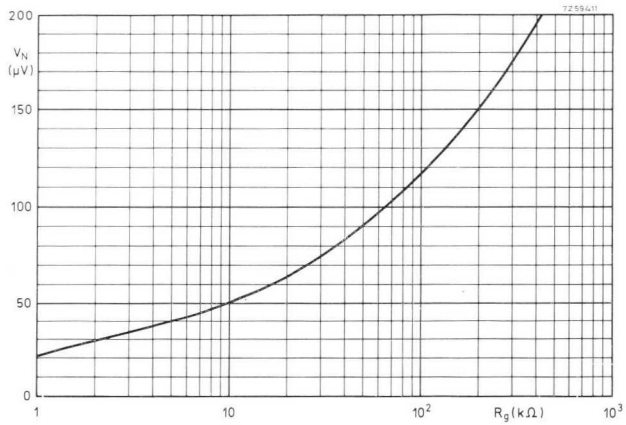

Fig. 2.16. Total distortion and noise voltage at output of 30 dB amplifier.



(a) distortion



(b) noise

Fig. 2.17. Total distortion and noise voltage at output of 40 dB amplifier.

2.3.2. CIRCUIT 2 - LOW-DISTORTION, HIGH-OUTPUT VOLTAGE AMPLIFIER

Fig. 2.18 shows the circuit of an amplifier having a total distortion of 0.11 % at 1000 Hz and maximum output. The amplifier has a voltage gain of 20 dB and a maximum output voltage of 10 V. To achieve this high output voltage with low distortion, the supply voltage has been raised from 18 V to 45 V. The frequency response (-3 dB points) is from < 20 Hz to > 20000 Hz, and the input and output impedances are 140 k Ω and 200 Ω respectively. The variation of total distortion with output voltage is given for three frequencies in Fig. 2.19.

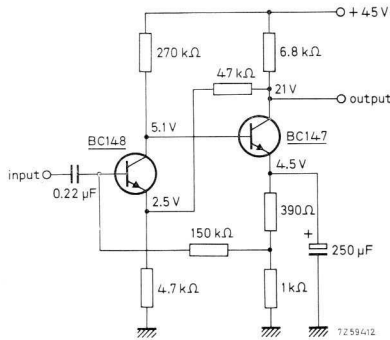

Fig. 2.18. Circuit of low-distortion high-output amplifier.

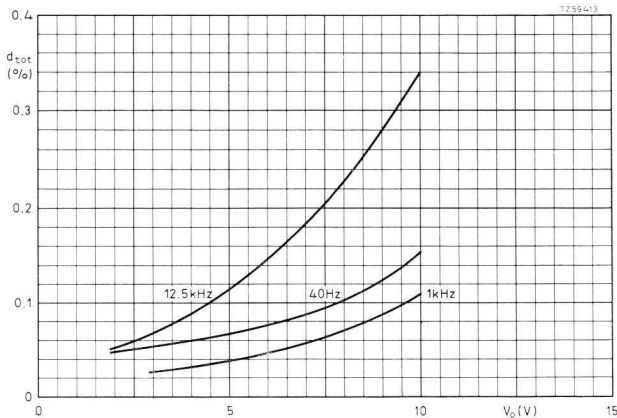

Fig. 2.19. Total distortion of the amplifier shown in Fig. 2.18. Note the high output voltage.

2.3.3 CIRCUIT 3 - BUFFER AMPLIFIER

A buffer amplifier circuit is shown in Fig. 2.20. Its first stage works in the common-emitter configuration with a large amount of feedback, while the second stage is an emitter follower. The circuit provides a high input impedance of $3.6\text{ M}\Omega$ and a low output impedance of $250\ \Omega$. Voltage gain is unity, the frequency response (-3 dB points) is from $< 20\text{ Hz}$ to $> 20\,000\text{ Hz}$. Fig. 2.21 shows the total distortion and noise voltage at the output.

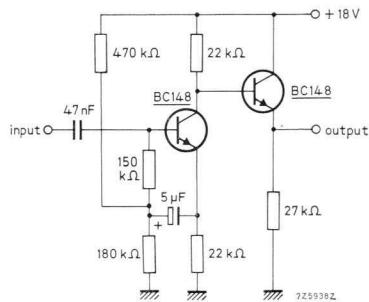
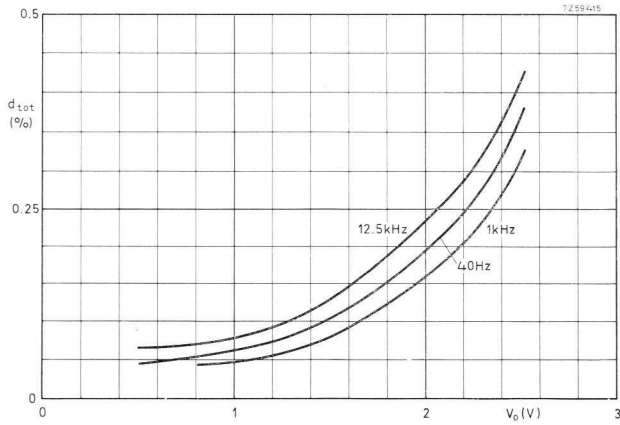
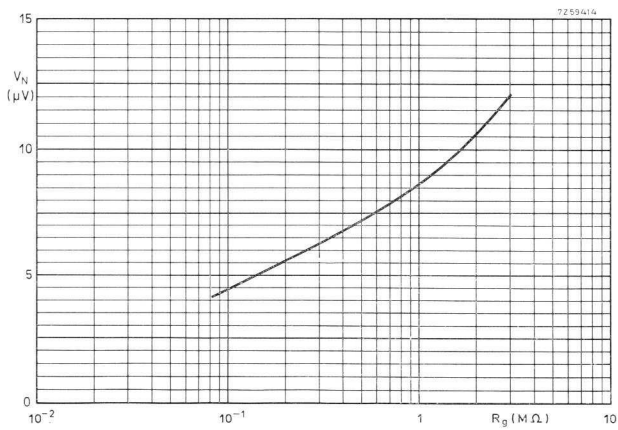

Fig. 2.20. Buffer amplifier circuit.



(a) distortion



(b) noise

Fig. 2.21. Total distortion and noise voltage at output of buffer amplifier.

2.3.4 CIRCUIT 4 - MICROPHONE AMPLIFIER

Fig. 2.22 shows the circuit of a microphone amplifier with a voltage gain adjustable between 13 dB and 40 dB. It has only 0.15 % distortion for a gain of 13 dB, and 0.75 % for a gain of 40 dB, with an output voltage of 2 V. The total distortion for the limiting values of voltage gain is given in Fig. 2.23. The values of noise voltage correspond to those of the 10 dB and 40 dB amplifiers given in Figs. 2.14 and 2.17 respectively. The input and output impedances and the frequency response (-3 dB points) are shown in Table 2.6.

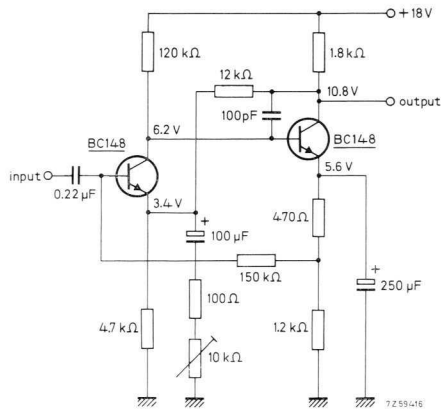
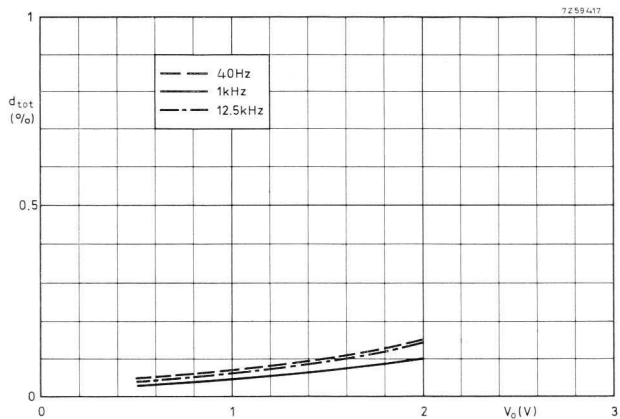

Fig. 2.22. Microphone amplifier circuit.

Table 2.6. Impedance and Frequency Response of Microphone Amplifier

impedance or frequency	gain 13 dB	gain 40 dB
Z_{in}	145 k Ω	120 k Ω
Z_{out}	47 Ω	120 Ω
f_{lower}	< 20 Hz	20 Hz
f_{upper}	\gg 20 kHz	20 kHz



(a) Voltage gain = 13 dB.

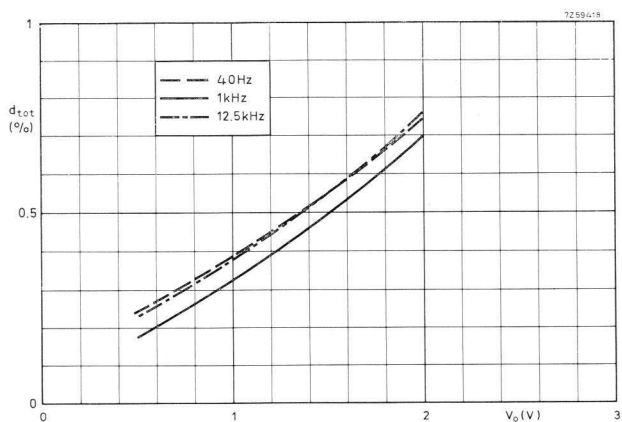

(b) Voltage gain = 40 dB.

Fig. 2.23. Total distortion of microphone amplifier.

2.3.5 CIRCUIT 5 - MIXER AMPLIFIER

The circuit of a mixer amplifier is given in Fig. 2.24. Here two inputs are fed to separate transistors which have a common collector load resistor. An emitter follower stage ensures a low output impedance of 70Ω and the input impedance is $2.5 \text{ M}\Omega$. At both inputs the voltage gain is unity.

Fig. 2.25 shows the total distortion of the mixer when a signal is applied to one input with the other input short-circuited. The distortion is 0.5% for 2 V output, and drops to 0.1% for outputs less than 0.5 V . To avoid exceeding 0.5% distortion, the voltage of each input should be restricted to 1 V , otherwise overloading can occur.

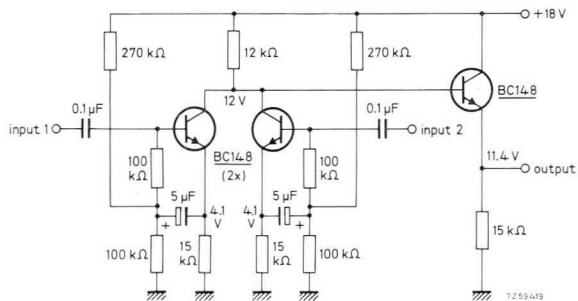

Fig. 2.24. Mixer amplifier circuit with two inputs.

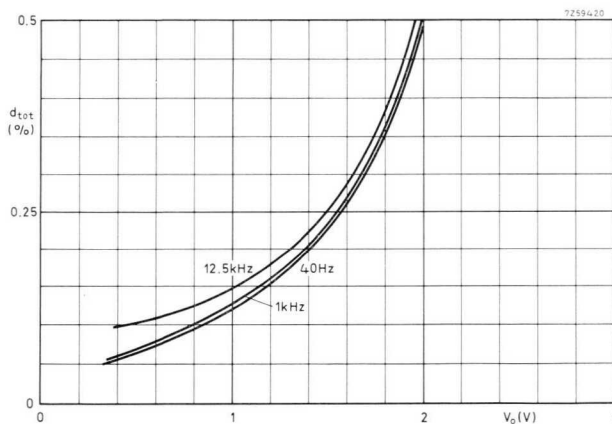

Fig. 2.25. Total distortion of mixer amplifier.

2.3.6 CIRCUIT 6 - MAGNETIC PICK-UP PRE-AMPLIFIER

The pre-amplifier circuit shown in Fig. 2.26 has a high input impedance and so permits a magnetic pick-up of any inductance to be used without change in the upper audio response. A choice of five equalization characteristics is offered for which component values are given in Table 2.7.

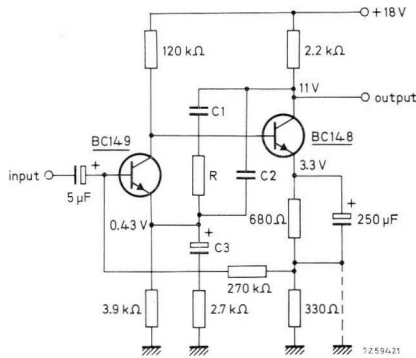

Fig. 2.26. Magnetic pick-up pre-amplifier circuit.

Table 2.7. Component Values for Magnetic Pick-up Pre-amplifier

circuit reference	equalization characteristic					units
	1	2	3	4	5	
R	56	56	56	47	47	$k\Omega$
C_1	12	5.6	6.8	6.8	6.8	nF
C_2	—	—	3.9	1.5	2.2	nF
C_3	25	25	1.5	3.2	5	μF

For characteristics 1 and 2 the electrolytic capacitor of 250 μF in the emitter circuit of the second transistor *must* be connected to earth. This is shown by the dotted line in Fig. 2.26.

The five equalization characteristics are shown in Figs. 2.27 and 2.28:

- Characteristic 1 corresponds with the old European recording characteristic (cross-over frequency 250 Hz) as used before the introduction of the micro-groove.
- Characteristic 2 corresponds with the recording characteristic which was applied in the U.S.A. up to 1940 and used in Europe up to about 1950 (cross-over frequency 500 Hz).
- Characteristic 3 represents the N.A.R.T.B. recording characteristic used in the U.S.A. up to about 1960.
- Characteristic 4 should be used for equalization of records made in Germany between 1952 and 1955. It has time constants of 3180 μ s, 318 μ s and 50 μ s.
- Characteristic 5 is the *present international standard* with time constants of 3180 μ s, 318 μ s and 75 μ s, suitable for mono and stereo records.

The discrepancies between these equalization characteristics and the required characteristics can be neglected. For example, equalization characteristic 5 shows up a difference of maximum -0.5 dB at 30 Hz and maximum $+0.7$ dB at 15 kHz, i.e., it is within ± 1 dB of the R.I.A.A. requirement.

The corresponding voltage gain at 1000 Hz, and the input output impedances for the different equalization characteristics are given in Table 2.8. The distortion at 1 kHz and 4 V amounts to 0.25 % and is below 0.1 % for output voltages below 1.5 V. The noise voltage at the output is 22 μ V, measured with a generator source resistance of 1 k Ω at the input.

This pre-amplifier is suitable for feeding into the “radio” or “auxiliary” input on most amplifiers.

Table 2.8. Voltage Gains and Impedances for Magnetic Pick-up Pre-amplifier

gain or impedance	equalization characteristic					units
	1	2	3	4	5	
gain	30	30	25	27	26	dB
Z_{in}	250	250	250	250	250	k Ω
Z_{out}	160	160	190	240	240	Ω

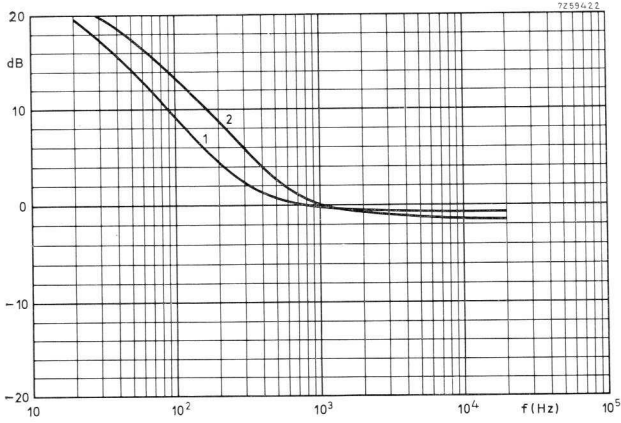

Fig. 2.27. Equalization characteristics 1 and 2 (see text).

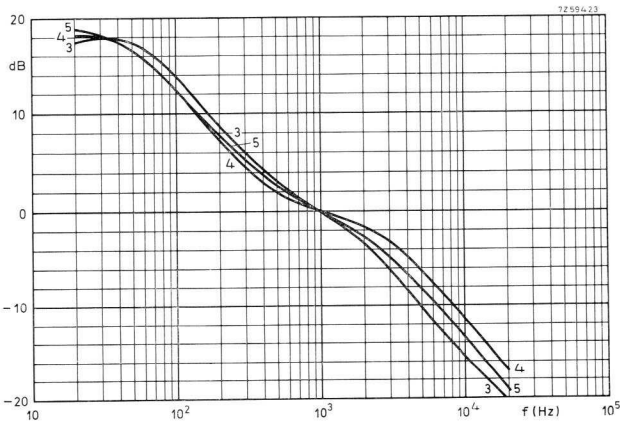

Fig. 2.28. Equalization characteristics 3, 4 and 5 (see text).

2.3.7 CIRCUIT 7 - PRE-AMPLIFIER FOR PICK-UP, TAPE AND RADIO INPUTS

The circuit of an equalizing pre-amplifier for use with magnetic and ceramic pick-up cartridges, radio, and tape playback heads is given in Fig. 2.29.

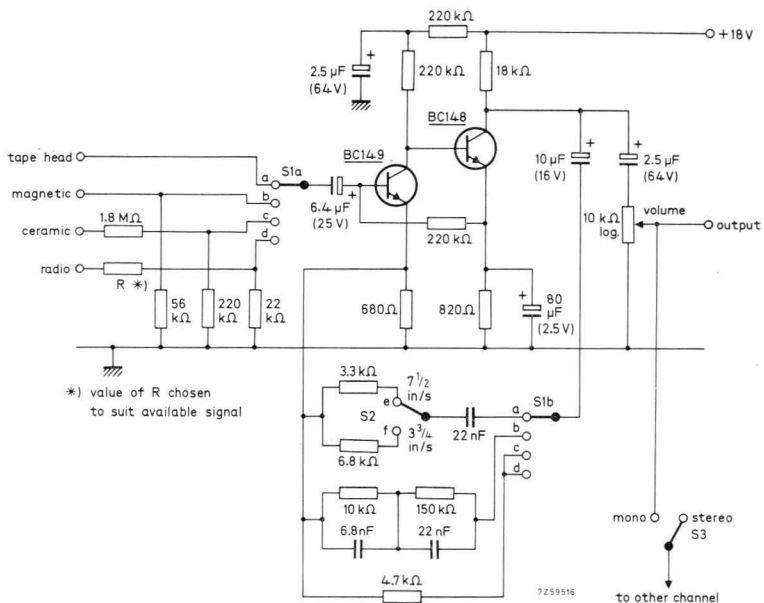

Fig. 2.29. Pre-amplifier circuit for pick-up, tape and radio inputs.

A BC149 and a BC148 form a directly coupled pair, the base voltage of the BC149 being derived from the emitter of the BC148. Equalization is obtained by feedback from the collector of the BC148 to the emitter of the BC149. The equalization characteristics are shown in Figs. 2.30 and 2.31.

No value is given for R , the input resistor for the radio position, because this should be chosen to suit the available signal.

For an output of 60 mV, the sensitivity for the various inputs at 1000 Hz is:

magnetic pick-up	4 mV
ceramic pick-up	170 mV
tape head with tape	
speed $7\frac{1}{2}$ in/s (19.1 cm/s)	6.5 mV

The total distortion of the pre-amplifier plotted as a function of the output voltage, is shown in 2.32.

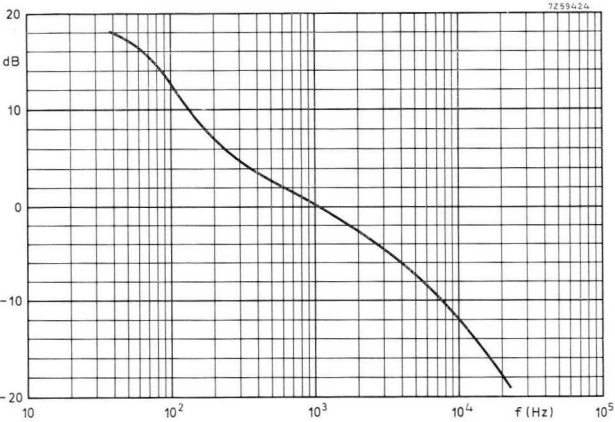

Fig. 2.30. Equalization characteristic of pre-amplifier for magnetic pick-up input.

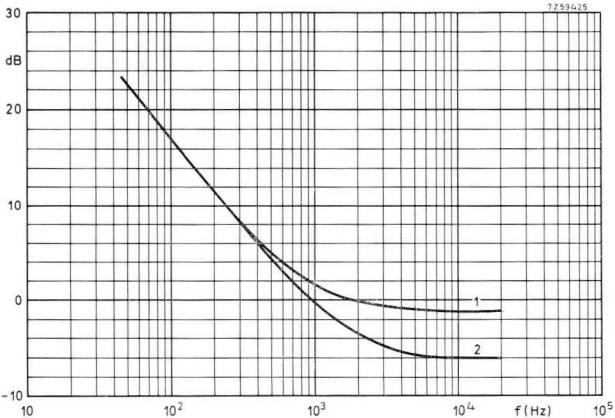

Fig. 2.31. Equalization characteristic of pre-amplifier for tape head inputs. Curve 1 is for a tape speed of $3\frac{3}{4}$ in/s and Curve 2 is for $7\frac{1}{2}$ in/s (9.5 and 19 cm/s).

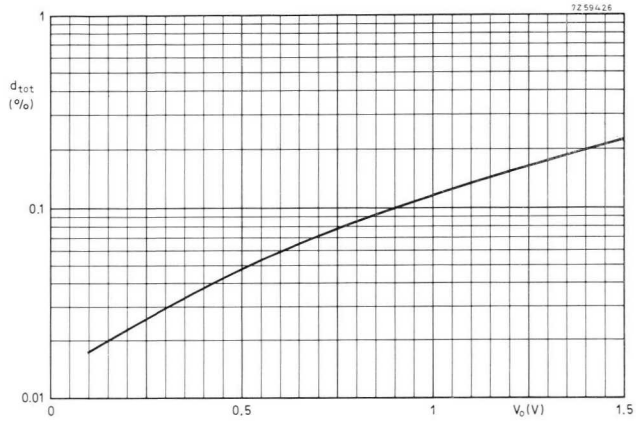

Fig. 2.32. Total distortion at output of pre-amplifier shown in Fig. 2.29.

2.3.8 UNIVERSAL PRE-AMPLIFIER

The Universal Pre-amplifier about to be described was designed specifically for operation with the 15 W, 25 W and 40 W high fidelity power amplifiers which are described fully in Chapter 3. It is suitable, nevertheless, for use with a wide range of power amplifiers since it will deliver a nominal output voltage of 440 mV/1 k Ω .

The pre-amplifier employs high levels of a.c. and d.c. feedback ensuring a very low distortion level ($< 0.15\%$) and variations from the nominal performance characteristics given here due to component tolerances are negligible.

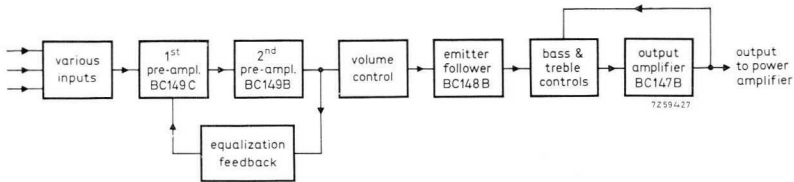

Fig. 2.33. Block diagram of Universal Pre-amplifier.

There are five different inputs: crystal pick-up, magnetic pick-up, radio tuner, tape recorder and magnetic microphone. In the magnetic pick-up position the amplitude/frequency characteristic is in accordance with the R.I.A.A. standard. In addition, the pre-amplifier provides an output signal of 0.35 mV/1 k Ω for tape recording.

In Table 2.9 the input sensitivity, input impedance, frequency response (-1 dB points) and the unweighted signal noise ratio are given for the various types of inputs. Sensitivities and input impedances are given at a frequency of 1000 Hz for an output signal level of 440 mV. The signal/noise ratios are given for an output signal level of 20 dB below 440 mV, i.e., 44 mV.

The block diagram of the universal pre-amplifier is shown in Fig. 2.33. Four n-p-n transistors of the BC147 family are employed. The first two amplifier stages are direct coupled with d.c. feedback, and different amounts of a.c. feedback are applied depending on the type of input.

The circuit diagram is given in Fig. 2.34. In the magnetic pick-up position the feedback loop R_{15} - C_5 - C_6 provides equalization according

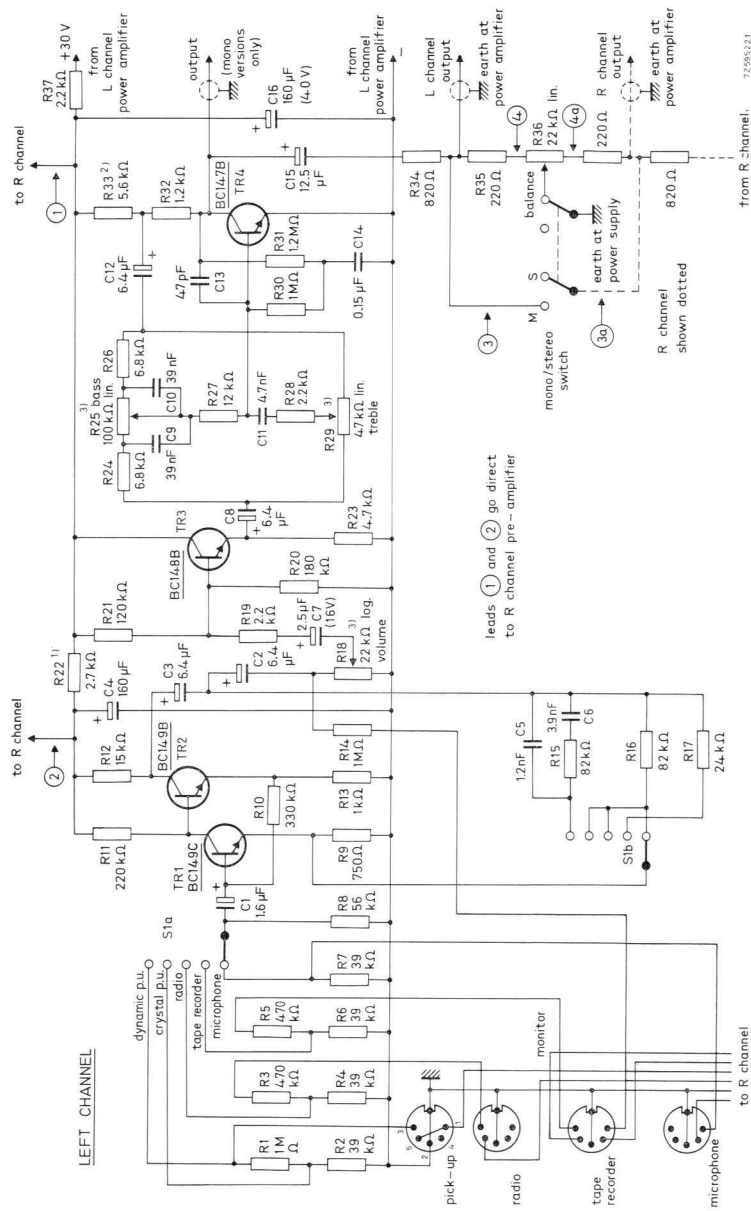

Fig. 2.34. Universal Pre-amplifier circuit (for notes, see foot of next page).

Table 2.9. Performance Characteristics of Universal Pre-amplifier

input	sensitivity (mV)	input impedance (k Ω)	frequency response	unweighted signal/noise ratio (dB)
crystal pick-up	300	1000	10 Hz - 35 kHz	> 80
magnetic pick-up	4	47	see Fig. 2.35	> 90
radio tuner	150	500	10 Hz - 35 kHz	> 80
tape recorder	300	500	10 Hz - 45 kHz	> 85
magnetic microphone	3.5	22	10 Hz - 65 kHz	> 80

to the R.I.A.A. characteristic. All other inputs are frequency independent and have a flat response. To obtain a low noise level a BC149C has been used as the input transistor, whilst the second pre-amplifier is a BC149B. The overdrive ratio of the first two stages is > 20 dB with respect to 350 mV across the volume control R_{18} . The voltage gains from the inputs to the top of the volume control at 1000 Hz are:

crystal pick-up	1.3 dB
magnetic pick-up	38.84 dB
radio tuner	7.34 dB
tape recorder	1.3 dB
magnetic microphone	40 dB

A BC148B is employed in an emitter-follower stage, to obtain a high input impedance and a low output impedance. As a result, the operation of the tone control circuit is independent of the position of the slider of the volume control potentiometer.

Notes to Fig. 2.34 (page 34)

- 1) R_{22} is omitted in R channel pre-amplifier, together with C_4 , R_{37} and C_{16} . For mono only, R_{22} and R_{37} are each replaced by 4.7 k Ω and C_{15} , R_{34} and R_{35} omitted.
- 2) Pre-amplifier delivers 440 mV suitable for driving 40 W amplifier with this value for R_{33} . For use with 15 W and 25 W amplifiers output may be reduced to 350 mV by making R_{33} equal to 6.8 k Ω and R_{32} short circuit.
- 3) Only one channel is shown here. For stereo, ganged potentiometers may be used.

The tone control circuit is of the feedback type, the bass and treble potentiometers being connected in the feedback loop between the collector and base of the output transistor TR_4 . This feedback system has the advantage of a low output impedance being maintained, while the bass and treble controls can be varied independently over a wide range. When the sliders of the bass and treble control potentiometers are at mid-positions, the feedback is practically independent of frequency. The equalization characteristic for the magnetic pick-up is given in Fig. 2.35 and the frequency response and tone control characteristics in Fig. 2.36.

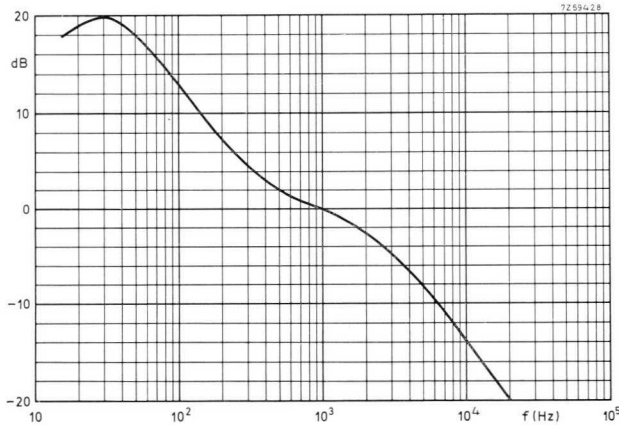

Fig. 2.35. Equalization characteristic for magnetic pick-up.

This pre-amplifier may be used in mono applications and for such purposes the audio output is taken from the collector of the output transistor TR_4 . This stage has a voltage gain of the order of 2.6 dB. If the input circuit of the power amplifier has no series capacitor, then an electrolytic capacitor of $6.4 \mu\text{F}/25 \text{ V}$ should be inserted between the pre-amplifier and the power amplifier.

For stereo applications two pre-amplifiers are used, the collectors of the output transistors being joined by a series network comprising $C_{15}-R_{34}-R_{35}-R_{36}$, and so on in the other channel. R_{36} serves as the stereo balance control, its slider being connected to earth when stereo programme material is reproduced. At the mid-point of its setting the decrease

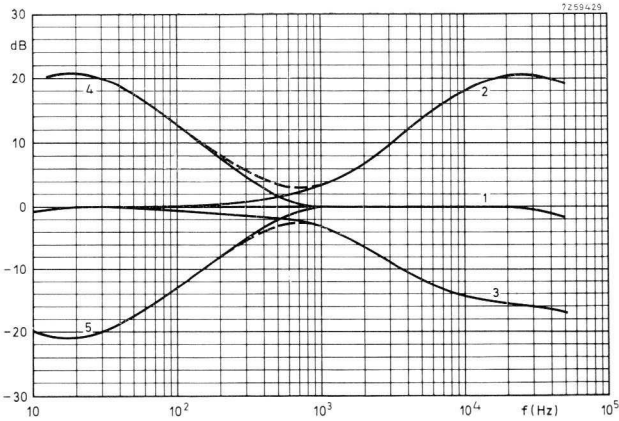

Fig. 2.36. Frequency response characteristic of Universal Pre-amplifier.

Curve 1: bass and treble controls in mid-position;

Curve 2: maximum treble, bass flat;

Curve 3: minimum treble, bass flat;

Curve 4: maximum bass, treble flat;

Curve 5: minimum bass, treble flat.

When maximum bass and maximum treble are applied together, curves 2 and 4 are joined by the dotted line. Similarly, when the bass and treble controls are both at minimum, curves 3 and 5 are joined by the dotted line.

in voltage amplification is about 0.6 dB. Resistors R_{34} and R_{35} are mounted on the printed-wiring board and the leads marked 3 and 4 in Fig. 2.34 are taken to the externally mounted mono/stereo switch and balance control respectively. Audio output is taken from the junction of R_{34} and R_{35} . No series capacitor is required if the pre-amplifier is used for driving the 15 W, 20 W, 25 W or 40 W power amplifiers described later, but where the 8 W amplifier is used, or any other power amplifier which has no input capacitor, a 6.4 $\mu\text{F}/25\text{ V}$ electrolytic capacitor must be inserted in series, its negative connection to the junction of R_{34} and R_{35} .

In the mono position of the mono-stereo switch, the output voltages of the two amplifiers are combined, the slider of the balance control being disconnected from earth.

As shown with the component values in Fig. 2.34 the pre-amplifier will deliver a nominal output voltage of 440 mV. This is the correct level for driving the 40 W power amplifier described in the next Chapter.

The input signal level required for the 15 W and 25 W amplifiers is, however, 350 mV and the pre-amplifier output voltage can be reduced to this level by making R_{33} equal to 6.8 k Ω and replacing R_{32} by a shorting link. Other values of output voltage may be obtained by changing the values of R_{32} and R_{33} correspondingly. The overdrive ratio of the complete pre-amplifier is > 20 dB with respect to the nominal output voltage of 440 mV, so the undistorted maximum output is > 4.4 V.

The supply voltage for the pre-amplifier is 30 V. Where the output power amplifier has a regulated supply unit the d.c. voltage for the pre-amplifier can be obtained from there via the series resistor R_{37} . Accommodation for this resistor has been provided on the printed-wiring board. If no stabilized supply is available the use of an additional active smoothing filter is recommended and a circuit is shown in Fig. 2.37. This filter should be connected between the pre-amplifier and the power supply unit.

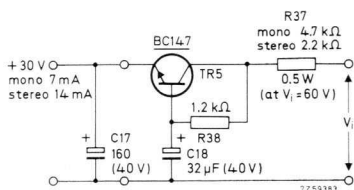

Fig. 2.37. Circuit of additional smoothing filter for use where a stabilized supply is not available. C_{17} is located on the printed-wiring board. When a stabilized supply is used, R_{37} is also mounted on the printed-wiring board (see Fig. 2.39).

The first two stages of the pre-amplifier have an additional decoupling network comprising R_{22} and C_4 . For stereo installations these components are necessary in only *one* pre-amplifier, the supply voltage being taken directly to the other channel from the point in the circuit immediately following R_{22} . This is the lead marked 2 in Fig. 2.34. Similarly, transistors TR_3 and TR_4 in the other channel are fed directly from R_{37} via the lead marked 1 in Fig. 2.34. Total d.c. consumption for one pre-amplifier is 7 mA.

For mono applications, where only one pre-amplifier is employed, resistors R_{11} and R_{37} are each replaced by 4.7 k Ω . Output circuit components C_{15} , R_{34} and R_{35} are also omitted, since the audio output is taken from the collector of TR_4 , as previously described.

The printed-wiring board for the L-channel pre-amplifier and its component layout are shown in Figs. 2.38 and 2.39 respectively, whilst those for the R-channel are shown in Figs. 2.40 and 2.41. Fig. 2.42 shows the external connections which have to be made to the L-channel pre-amplifier. The volume, balance and tone controls, together with the mono/stereo switch and input selector switch are mounted on the front panel of the unit enclosure. Input sockets would normally be situated on a rear panel. For stereo installations the L- and R-channel printed-wiring boards should be mounted reasonably close together in order to keep interconnections as short as possible.

The reader is referred to Section 3.4 and particularly Fig. 3.8 where details are given of the interconnection of units to avoid earth loops. These recommendations should be followed wherever possible, otherwise feedback troubles are likely to arise.

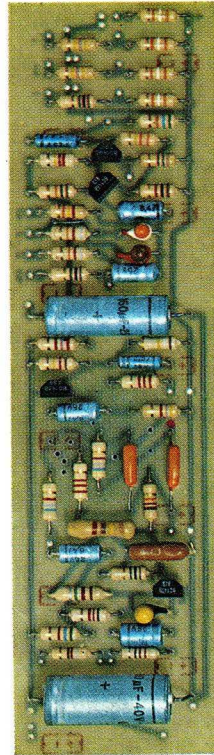

Photograph of the Universal Pre-amplifier, illuminated to show the printed wiring on the reverse side.

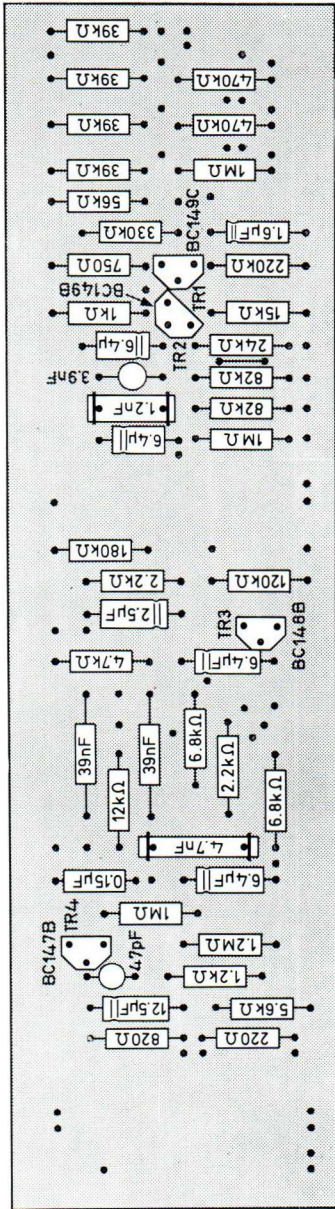

7259518

Fig. 2.41. Printed-wiring board for right channel pre-amplifier.

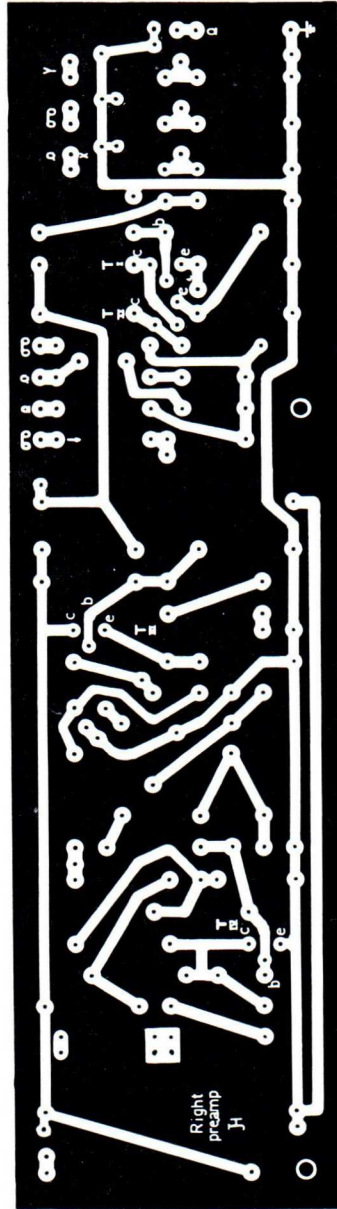
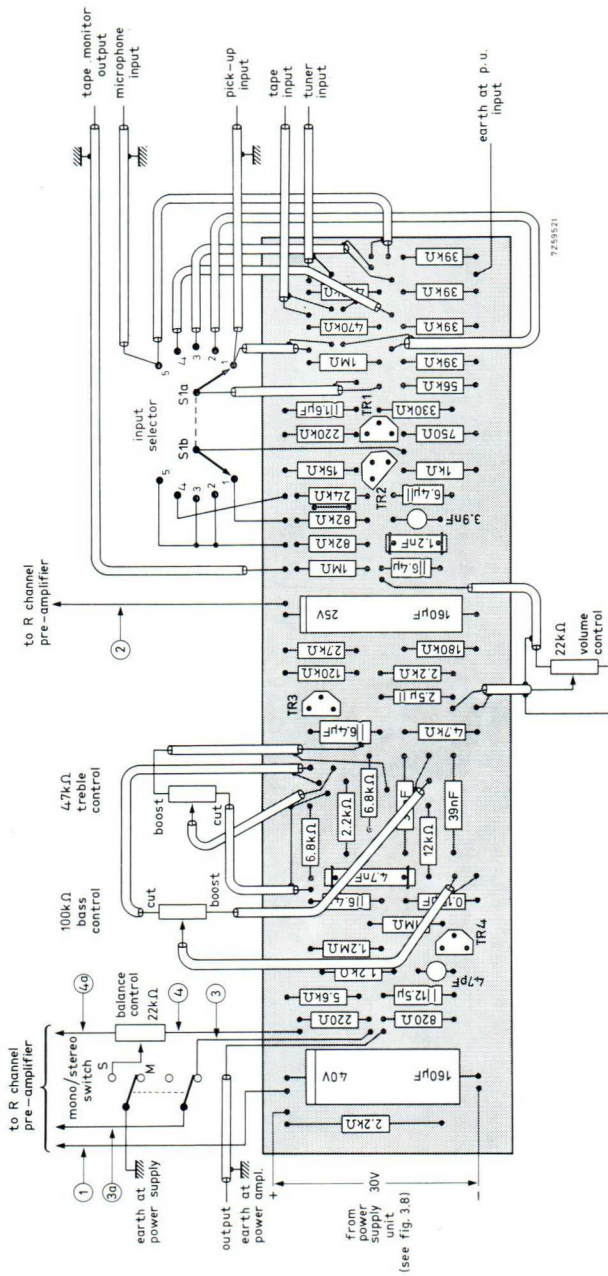

Fig. 2.40. Component layout of right channel pre-amplifier.



7259321

Fig. 2.42. Location of external connections to left channel pre-amplifier. Numbered connections refer to those similarly numbered in Fig. 2.34.

2.4 Control Circuits

2.4.1 CIRCUIT 9 - INPUT SWITCHING ARRANGEMENTS

The compatibility of hi-fi units is always something of a problem and many difficulties in operation have arisen due to incorrect impedance matching and unsatisfactory signal input level. The problem of input and output impedance is much less than hitherto, thanks to standardization between equipment manufacturers but the problem of signal level still remains.

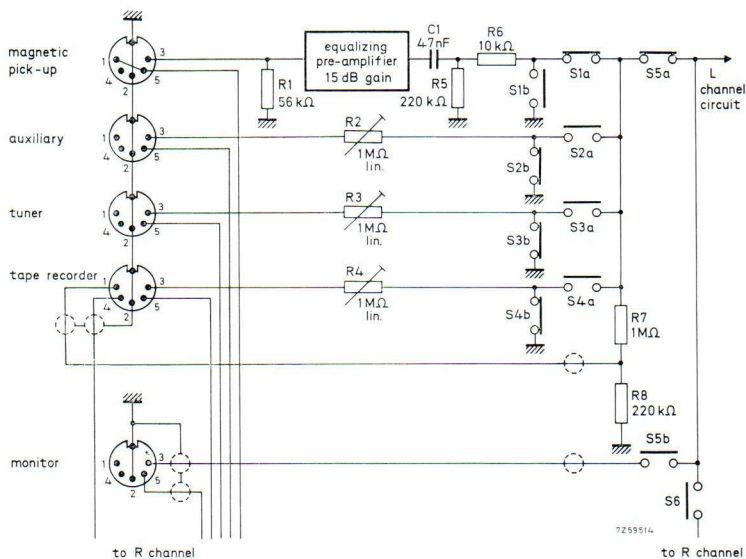

Fig. 2.43. Input switching arrangements. Switch functions are as follows:

- | | |
|------------------------|---------------------|
| S_1 magnetic pick-up | S_4 tape playback |
| S_2 auxiliary input | S_5 monitor head |
| S_3 tuner | S_6 mono. |

Figs. 2.43 offers the constructor a solution to this problem, resistors R_2 , R_3 and R_4 acting as variable input attenuators in conjunction with resistors R_7 and R_8 . Where excessive signal levels are present, adjustment of the preset potentiometers should be carried out so that the same out-

put power, and hence the volume, is obtained irrespective of the type of input selected. This will avoid the volume control having a different setting for each input. A suitable level should be first selected with the magnetic pick-up in use, after which the appropriate presets are adjusted for the same volume level.

Switches S_1 to S_4 select the input required, whilst shorting to earth the unwanted inputs. An output signal for recording purposes is taken from the junction of R_7 and R_8 to the tape recorder socket. Switch S_5 connects the amplifier circuit which follows to a monitor tape head, so that the recorded programme can be instantly compared with the "original". This facility applies only to tape recorders with separate record and playback heads, or where an extra monitor head is fitted. Switch S_6 combines the L- and R-channels for mono.

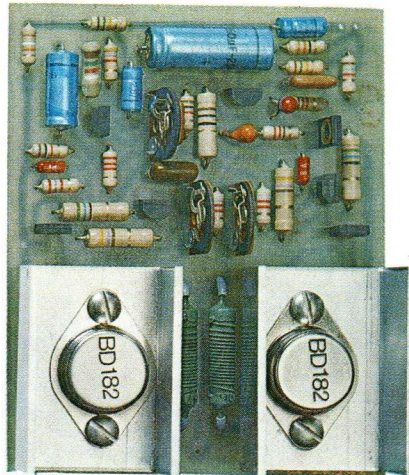

The 25 W high fidelity power amplifier described on page 100 measures only 11.75 cm long \times 9.5 cm wide.

2.4.2 CIRCUIT 10 - STEREO BALANCE CONTROL

The balance control circuit of Fig. 2.44 enables the voltage gain of both stereo channels to be varied by 6 dB in opposite directions. The controlling variable resistor forms part of the feedback circuit. Average gain is 23.4 dB, and Fig. 2.45 gives the total distortion for maximum and minimum gain. The differences are only small because of the large amount of feedback employed. The noise voltage corresponds to that of the 20 dB version of the basic amplifier given in Fig. 2.8. The frequency

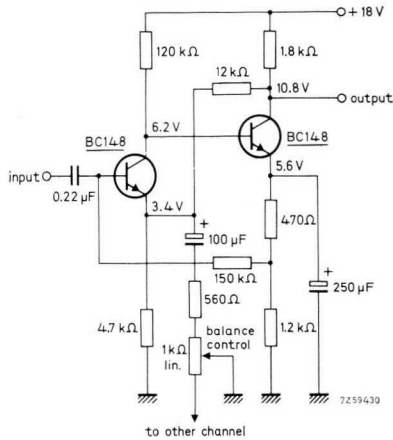
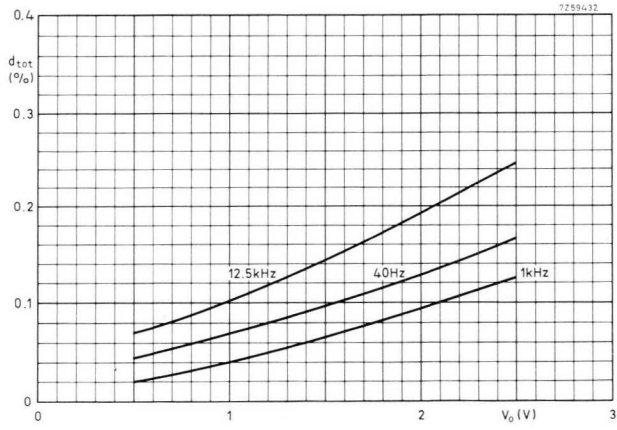
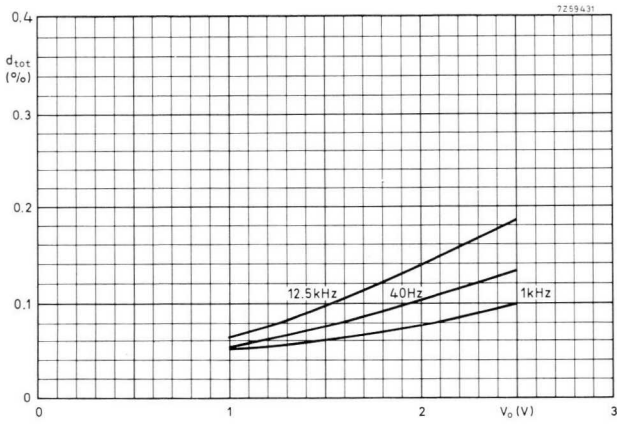

Fig. 2.44. Stereo balance control circuit.

response (-3 dB points) is from < 20 Hz to > 20000 Hz, whilst the input and output impedances are 140 k Ω and 85 Ω respectively.



Maximum gain



Minimum gain

Fig. 2.45. Total distortion of balance control circuit.

2.4.3 CIRCUIT 11 - STEREO BALANCE METER

Most stereo equipment is fitted with a balance control to achieve aural equality of the two channels. Lack of sensitivity of the ear in detecting small changes in volume levels can make the operation of balancing somewhat tedious if precision is required and a visual indication that balance has been achieved will ease the task considerably.

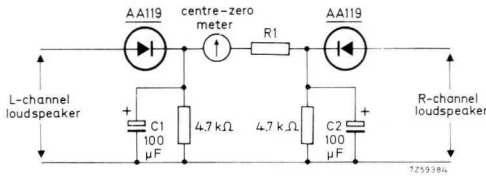

Fig. 2.46. Stereo balance meter circuit.

A simple meter circuit which may be used for balancing the outputs in a stereo system is shown in Fig. 2.46. Capacitors C_1 and C_2 damp the meter movement and resistor R_1 is chosen to suit the current rating of the centre-zero moving coil meter and the amplifier output. The value of R_1 would be typically 10 kΩ for a meter having a 1 mA movement.

2.4.4 CIRCUIT 12 - ACTIVE TONE CONTROL

Fig. 2.47 shows an active tone control circuit which employs a frequency-dependent feedback network between the collector and the base of the transistor. For input voltages less than 250 mV the total distortion remains below 0.1%, rising to 0.85% for an output voltage of 2 V at 12500 Hz. The variation of total distortion with output voltage is shown for three frequencies in Fig. 2.48.

The tone control characteristics are shown in Fig. 2.49. The range of control extends from -22 to $+19.5$ dB at 30 Hz, and from -19 to $+19.5$ dB at 20 kHz. With the controls at their mid-positions the voltage gain is 0.91. The input and output impedances at 1 kHz are $40\text{ k}\Omega$ and $180\ \Omega$ respectively.

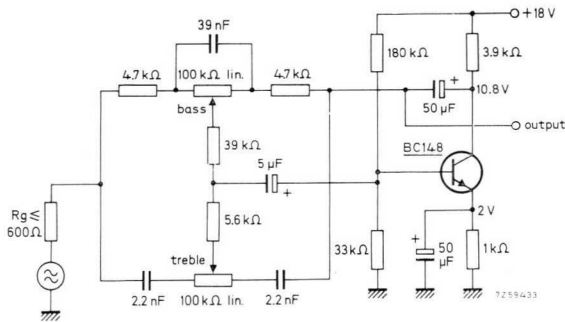

Fig. 2.47. Active tone control circuit.

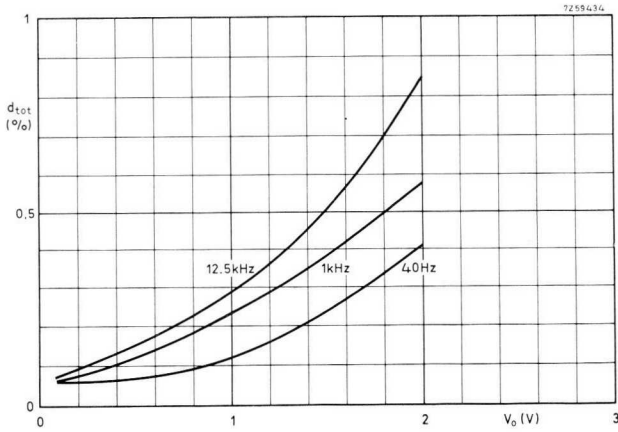

Fig. 2.48. Total distortion of active tone control.

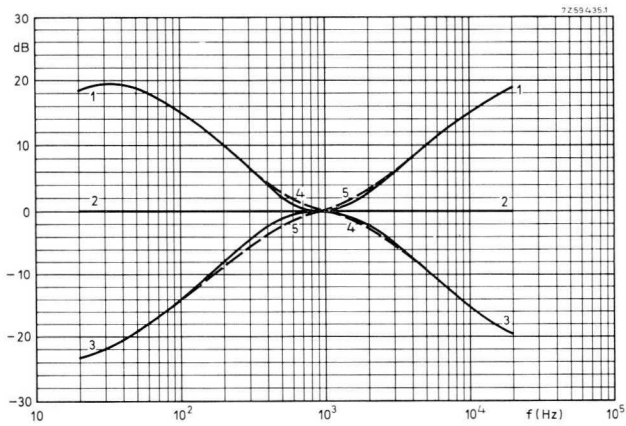

Fig. 2.49. Characteristics of active tone control circuit.

- Curve 1: maximum bass boost, maximum treble boost;
- Curve 2: linear frequency response (controls flat);
- Curve 3: maximum bass cut, maximum treble cut;
- Curve 4: maximum bass boost, maximum treble cut;
- Curve 5: maximum bass cut, maximum treble boost.

2.4.5 CIRCUIT 13 - SOUND SOURCE WIDTH (DIMENSION) CONTROL

The apparent width of the "sound stage" can be varied in stereo systems by deliberately introducing cross-talk between the channels, part of the signal voltage of one channel being added to the second channel. The circuit shown in Fig. 2.50 provides continuous control between in-phase cross-talk of 100%, corresponding to mono operation, and anti-phase cross-talk of 24%. Greater anti-phase cross-talk is not required since the sound impression will fall apart for greater values.

The voltage gain of the circuit is 0.5. Input and output impedances are 750 kΩ and 47 Ω respectively, and the frequency response (−3 dB points) is from < 20 Hz to > 20 000 Hz. Fig. 2.51 shows the total distortion of the circuit as a function of output voltage for three frequencies.

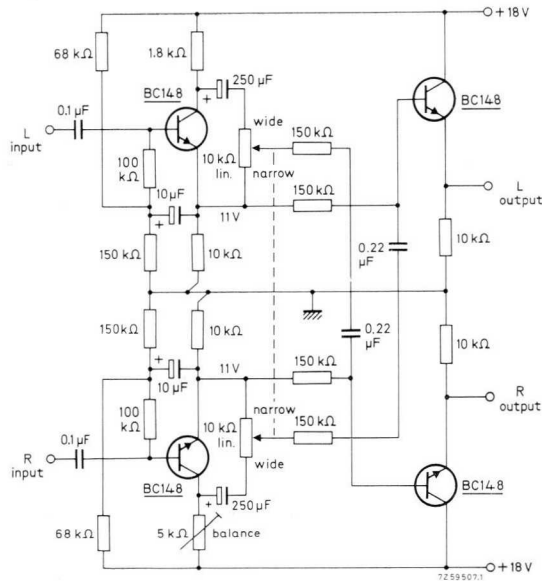

Fig. 2.50. Sound source width (dimension) control circuit.

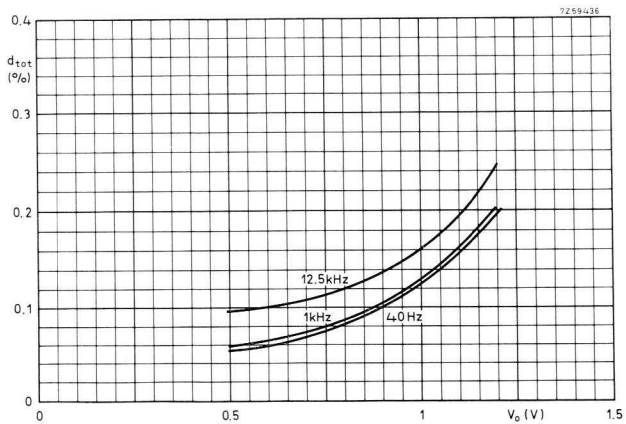

Fig. 2.51. Total distortion of sound source width control.

2.4.6 CIRCUIT 14 - LOW-PASS/HIGH-PASS FILTER

In Fig. 2.52 the circuit of a low-pass/high-pass filter is shown. It consists of two RC networks connected in series with a buffer amplifier, the circuit of which was given in Fig. 2.20. The frequency characteristics are shown in Fig. 2.53.

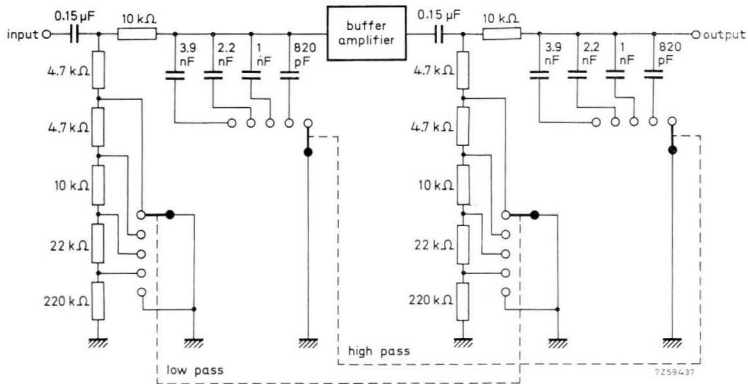

Fig. 2.52. Low-pass/high-pass filter circuit.

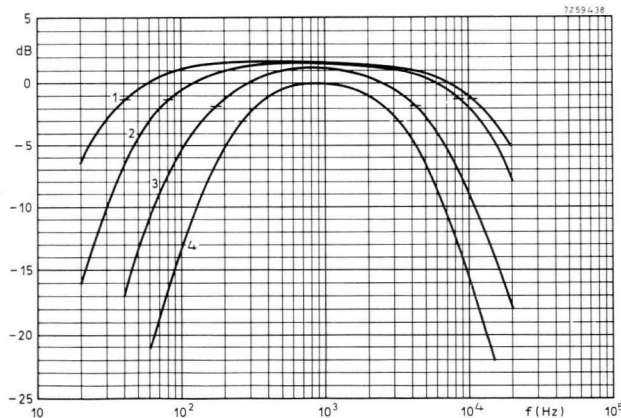

Fig. 2.53. Frequency characteristics of the low-pass/high-pass filter. The -3 dB points of the curves are as follows:

Curve 1: 40 Hz and 11 kHz

Curve 3: 160 Hz and 4.5 kHz

Curve 2: 80 Hz and 9 kHz

Curve 4: 270 Hz and 3.2 kHz.

2.4.7 CIRCUIT 15 - NOISE AND RUMBLE FILTER

The circuit of a noise and rumble filter is shown in Fig. 2.54. Bass and treble cut are produced by an RC network connected between two emitter followers, and a feedback loop from the output to the input through a second RC network. A high slope of around 13 dB/octave is achieved. The frequency limit of the rumble filter is fixed at 45 Hz, but the noise filter can be switched to limits of 16 000, 12 000 and 7000 Hz. The frequency characteristics are shown in Fig. 2.55.

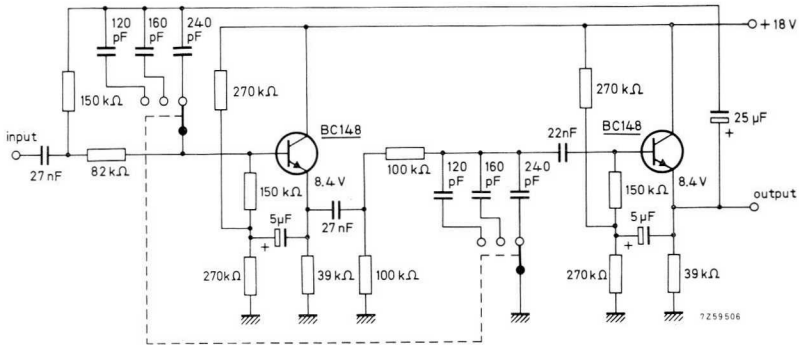

Fig. 2.54. Noise and rumble filter circuit.

The voltage gain is 0.95 and the total distortion at 1000 Hz and an output voltage of 2 V is 0.35 %, falling to less than 0.1 % at 1 V. The input and output impedances are 1.7 M Ω and 450 Ω respectively.

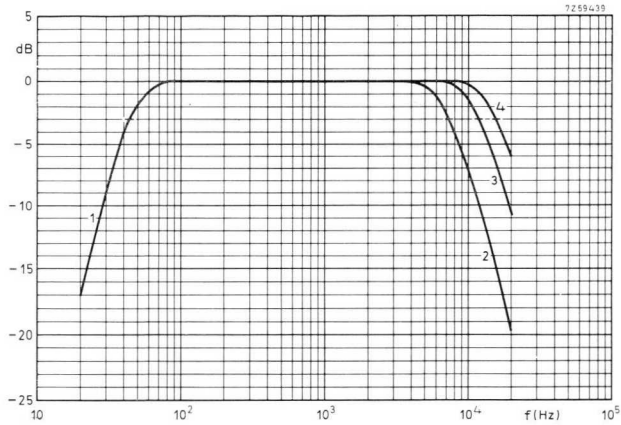

Fig. 2.55. Frequency characteristics of noise and rumble filter.

The -3 dB points of the curves are as follows:

Curve 1: 45 Hz (applies to Curves 2,3 and 4);

Curve 2: 7 kHz;

Curve 3: 12 kHz;

Curve 4: 16 kHz.

2.4.8 CIRCUIT 16 - PRESENCE CONTROL

The active presence control circuit shown in Fig. 2.56 uses frequency selective negative feedback with amplitude control to achieve up to 13 dB boost at 2000 Hz. The feedback network is a bridged-T filter. The frequency characteristics of the presence control circuit are shown in Fig. 2.57.

Nominal gain at flat response is 0.95 and the input and output impedances are 12 k Ω and 100 Ω respectively. The total distortion remains below 0.1% provided that the output voltage does not exceed 250 mV. The distortion characteristics are shown for three frequencies in Fig. 2.58

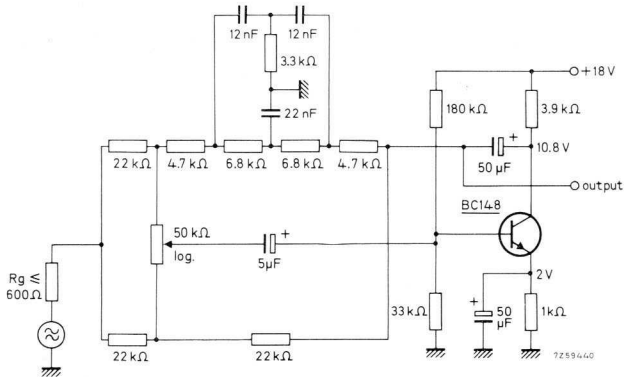

Fig. 2.56. Presence control circuit.

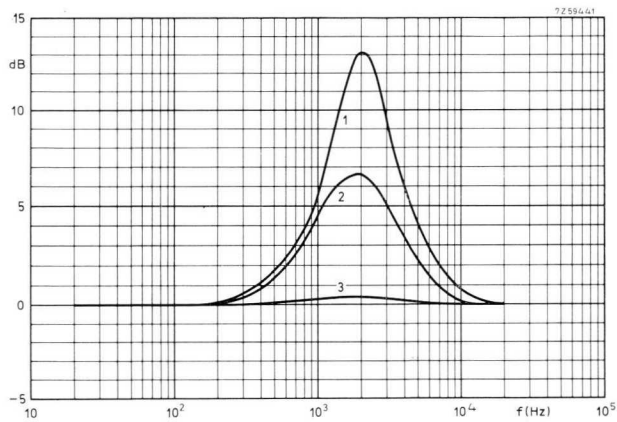

Fig. 2.57. Frequency characteristics of presence control circuit.
 Curve 1: maximum; Curve 2: mid-position; Curve 3: minimum.

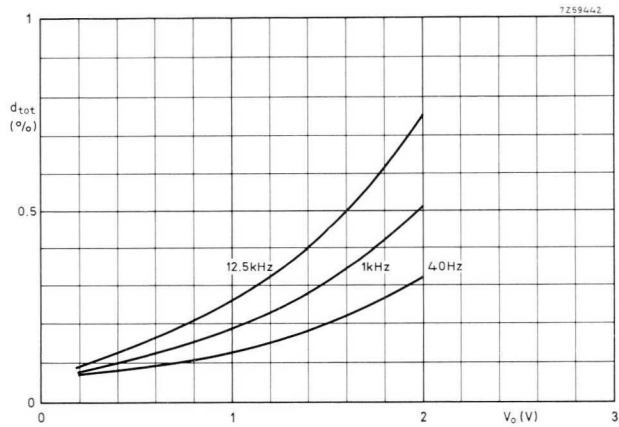

Fig. 2.58. Total distortion of presence control circuit.

3 Power Amplifiers

3.1 Performance Characteristics

3.1.1 GENERAL

In the discussion of the performance characteristics of power amplifiers which follows, the subject has been treated from a high fidelity standpoint since this represents the most stringent requirements. It is realised that high fidelity specifications do not apply to less expensive equipment and accordingly the performance specification may be relaxed to meet the less exacting requirements. Details of four economical power amplifier circuits are given in this Chapter, in addition to five circuits which meet the high fidelity specification.

3.1.2 DISTORTION

Frequency distortion occurs if the gain is a function of frequency and it is expressed on a relative gain/frequency basis. Using modern components, amplifiers having a response linear to within a fraction of a decibel over a wide frequency band are now commonplace. This has been achieved by omitting all frequency-conscious components, wherever possible, from the design and using directly-coupled stages in which no coupling capacitors are employed. Electrolytic capacitors for the input and output circuits of power amplifiers should be of high quality and a wide range of suitable components is available for this purpose.

Another reason for avoiding the use of capacitors is that they can cause phase distortion. When different frequency components suffer selective phase displacements the original waveform will not be preserved. To ensure that all frequency components of a complex waveform are transmitted through the amplifier at the same rate, the phase angle between the output and the input voltages should be independent of frequency. In other words, the phase angle for every frequency should be zero. Phase distortion is only detectable by the ear when a phase difference of many tens of cycles exists, or when the wavelength is comparable with the distance between the ears. This is of the order of 1,750 Hz. For frequencies below this, phase distortion remains undetectable unless the phase difference is larger, or a stereo system is used.

Because of the rising popularity of stereo systems, it is essential to

keep phase distortion in the reproduction chain to a minimum, otherwise there will be a loss of the sound-location faculty, and so the use of capacitors should be restricted. Where they must be used, they must be high quality components.

Non-linear distortion is the most objectionable form of distortion. It may be of two kinds: harmonic distortion and intermodulation distortion. Whilst 1% total harmonic distortion might be considered acceptable, the intermodulation products arising from non-linearity are intolerable and only a small proportion of these have to be present for the distortion to become unpleasant. In transistor amplifiers having high power outputs the main source of non-linear distortion is in the power output stage. High order odd harmonics are caused by slight discontinuities in the transfer characteristic at the cross-over point arising from the inherent asymmetry of a quasi-complementary output stage. For cross-over distortion to be eliminated it is therefore essential that a careful choice of components is made. Circuit 24 is a typical example of a high power audio amplifier design in which the total harmonic distortion does not exceed 0.1%.

Provided that non-linearity and phase distortion are low, transient distortion in a modern transformerless power amplifier is negligible, the main source of this distortion normally being the loudspeaker. Up to now the speaker has remained the last offending source of transient distortion, but recent developments have resulted in a new range of high fidelity loudspeakers becoming available. The transient-handling capabilities of these speakers is excellent, less than 1% distortion occurring with the 1" tweeter when it is correctly mounted.

3.1.3 DYNAMIC RANGE

Dynamic range is the ratio of maximum to minimum sound intensity, expressed in decibels. In any sound reproduction system it is also used to express the ratio of maximum to minimum signal which can be handled by all, or part, of the system. The maximum signal level is taken to be the full power output, normally measured at the onset of clipping, whilst the minimum signal level is determined by the noise level. Noise originates mainly in the pre-amplifier input stage and it can be clearly seen from Fig. 3.1 why it is so important to use low-noise components at the input of the pre-amplifier. The dynamic range is roughly equal to the signal/noise ratio.

In the concert hall a dynamic range of about 70 dB could be expected from a large orchestra, but with recorded music the dynamic range is less than this. High quality tape recordings played on professional machines do not have a dynamic range exceeding about 60 dB, and domestic standard tape recorders provide considerably less. The same

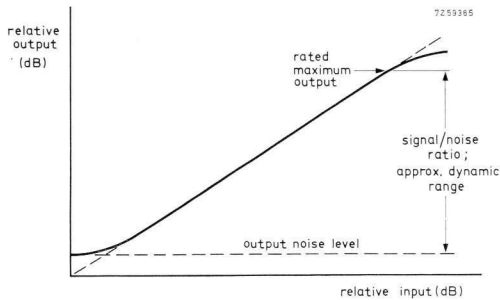

Fig. 3.1. Effect of noise level on dynamic range.

applies to disc recordings where a dynamic range of 55 to 60 dB is possible. Both AM and FM radio transmissions have amplitude limiting and volume compression applied, so it is unlikely that the listener will experience a dynamic range greater than 60 dB unless a microphone is used.

3.1.4 DAMPING FACTOR

The damping factor is the ratio of the internal resistance of the output of the amplifier to the impedance of the load.

With modern transformerless amplifiers in which feedback is generously applied, the internal resistance of the amplifier will be only a fraction of an ohm and a high damping factor will be easily achieved. This ensures that where, for example, a single full-range speaker with a power handling capacity of 40 W is mounted on an open baffle, adequate

damping can be obtained. A damping factor as high as a 100 could be applied in such a case, whereas a damping factor of 3 would be adequate for a modern sealed enclosure.

3.1.5 POWER BANDWIDTH

The power bandwidth is the frequency response at a particular level of high output power and low distortion. In most cases this response is measured at the onset of clipping, for a distortion of 1 %.

The practice of publishing only the amplitude/frequency response curves to illustrate the performance of an audio amplifier was sufficiently informative in the old days. With modern solid-state high fidelity amplifiers there is greater interest in power dependence on frequency and it is now common practice to publish the power/frequency characteristic, which shows the power performance of a high fidelity amplifier over its entire bandwidth, in addition to the amplitude/frequency characteristic.

3.1.6 OUTPUT POWER RATINGS

A number of different ways of defining the power output of an amplifier are in use. The most common are:

1. *Sine-wave Power*: the output power attained when the amplifier is sine-wave driven.
2. *Music Power*: the equivalent sine-wave power attained during passages of music. This may be as much as one-third higher than the sine-wave rating, but it depends on the regulation of the power supply. It is measured at a supply voltage which is equal to the zero signal d.c. supply voltage of the amplifier. Where a stabilized power supply is used, the amplifier voltages do not change and the music power is the same as the sine-wave power rating.

There are many other methods of defining the output power, such as "peak power" and "speech and music power", but the more common methods stated above are generally preferred. The ratings may be quoted:

- (a) at a specified distortion.
- (b) at clipping, where the working point of the transistors reaches the knee of the characteristic, resulting in a sudden increase in distortion of the output waveform.

Unless otherwise stated, the ratings of all amplifiers given in this book are quoted in terms of the *continuous r.m.s. sine-wave power which the amplifier will deliver for at least 10 minutes into a specified load with a total distortion of 1%*.

3.2 Output Stage Arrangements

3.2.1 GENERAL

A conventional push-pull output stage, with output transistors of the same polarity, requires the two input signals to be in anti-phase. These may be obtained from a driver transformer. But there are many disadvantages of using a transformer for phase-splitting, particularly its effect on the frequency response, and hence the power bandwidth.

The upper end of the audio system is affected by the stray inductance and capacitance of the transformer and the lower end by the primary self-inductance. In addition, the non-linear behaviour of core material introduces distortion. There are also copper losses, and dissipation of part of the a.c. driving power in the windings.

Not only do the above remarks apply to the driver transformer, but to the output transformer also. Distortion, efficiency and bandwidth depend to a very large extent on the quality of both transformers. Moreover, transformers for use in high quality audio amplifiers are expensive and bulky components, and even these do not completely eliminate losses and distortion.

A further drawback is that, being phase-shifting elements, transformers limit the amount of negative feedback which can be applied since there is always a chance that the feedback might become positive, giving rise to instability.

The most economical solution to eliminating the use of transformers is to employ p-n-p and n-p-n transistors in complementary symmetry. The small reduction in sensitivity due to the absence of the driver transformer is easily compensated for by the high gain of the latest transistors. Exceptionally, an additional stage of amplification may be necessary. A comprehensive range of complementary transistors is given on page 68.

3.2.2 PRINCIPLES OF COMPLEMENTARY OUTPUT STAGES

Fig. 3.2 shows the basic circuit of a complementary output stage. For

the sake of simplicity the components required for d.c. adjustment have been omitted. The transistors are assumed to operate in Class-B.

On positive half cycles of input voltage the n-p-n transistor is conducting and the p-n-p transistor is cut off, so that current i_p flows through the load resistance in the direction of arrow I. During the negative half cycles of the input signal, the p-n-p transistor is conducting and the current i_n flows through the load in the direction of arrow II. The n-p-n

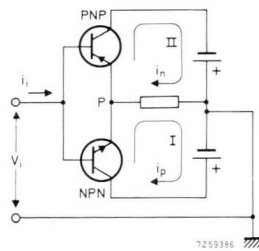

Fig. 3.2. Basic circuit of a complementary push-pull output stage.

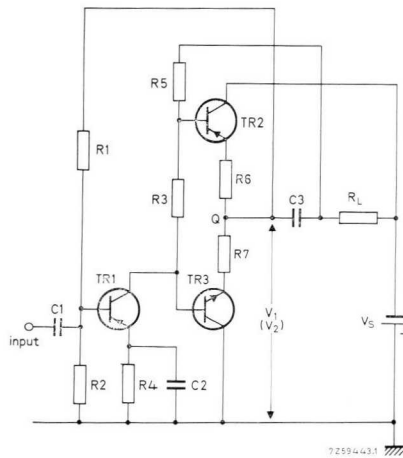

Fig. 3.3. Practical circuit arrangement of complementary output stage.

transistor is then cut off. The combined effect of these currents produces an output voltage across the load resistance.

For single power source operation, as shown in Fig. 3.3, one end of the load is connected for the negative line, while the other end is connected through capacitor C_3 to the common emitters. The d.c. voltage V_1 at the point Q is approximately half the supply voltage. The maximum output power of the circuit depends on the maximum ratings of the transistors, such as collector peak current, collector dissipation and knee voltage, on the load impedance R_L , and on the supply voltage V_S .

The driver stage is coupled directly to the output transistors; the collector resistor R_5 of the driver transistor is connected to the unearthed end of the load. In this way the current through resistor R_5 is reduced, because the voltage across R_5 is now the base voltage of the output transistor. The d.c. conditions of both the driver stage and the output stage are stabilized against temperature variations by applying d.c. feedback from the emitters of the output transistors to the base of the driver transistor by resistor R_1 , and by incorporating emitter resistors.

To minimise cross-over distortion, the output transistors must be biased to an emitter quiescent current of a few milliamperes. If both output transistors had the same polarity, this quiescent current could be obtained by applying a small negative base voltage with respect to the emitter voltage. Since, however, the transistors have opposite polarity, a positive and a negative base voltage with respect to the emitter voltage are required. These base voltages are obtained by means of resistor R_3 which is inserted in the collector circuit of the driver transistor TR_1 . Some asymmetry is introduced, and to minimise this, resistor R_3 must be given a low value.

The operation of the circuit is similar to that of Fig. 3.2. During the positive half cycles the n-p-n transistor conducts, thus lowering the value of V_1 , and during negative half cycles the p-n-p transistor conducts, raising the value of V_1 . The variations of V_1 are transferred to the load via C_3 .

As illustrated by Fig. 3.4, the a.c. excursions of the emitters of the output transistors are limited by several factors:

1. the peak value of the negative excursion at the onset of clipping, neglecting the voltage drop across C_3 is

$$-V_{RL} = V_S - V_1 - V_{R6} - V_{CEK2}$$

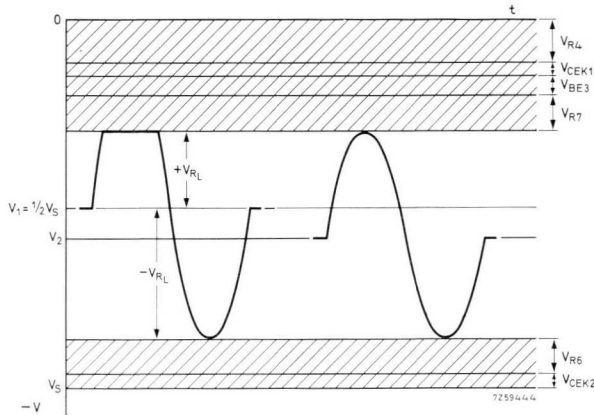

Fig. 3.4. Emitter voltages of a complementary pair of transistors.

2. the peak value of the positive excursion at the onset of clipping is:

$$V_{RL} = V_1 - V_{R7} - V_{BE3} - V_{CEK1} - V_{R4},$$

where V_{CEK1} and V_{CEK2} are the knee voltages of transistors TR_1 and TR_2 respectively.

It can be seen that if the voltage at the emitter junction of the output transistors under no-signal conditions is equal to $V_1 = \frac{1}{2} V_S$, the maximum permissible excursions are no longer equal in both directions. To ensure equal voltage excursions in both directions, point Q should be biased to a potential V_2 which neutralises the differences in potential, so that V_2 becomes:

$$V_2 = \frac{1}{2} [V_S - V_{CEK2} + V_{BE3} + V_{CEK1} + V_{R4}].$$

From Fig. 3.4 it can also be seen that no clipping will occur as a result of the knee voltage of the n-p-n transistor TR_3 being exceeded, since:

$$V_{CEK3} < V_{R4} + V_{CEK1} + V_{BE3}.$$

In practice, resistor R_3 is a preset potentiometer with its slider connected to one end, and adjustment of the quiescent current is a simple operation. A thermistor may be connected across resistor R_3 to compensate for the temperature dependence of the quiescent current.

3.2.3 QUASI-COMPLEMENTARY SYMMETRY

Complementary transistors for large power outputs are rather difficult to make economically. Therefore in high-power amplifiers complementary transistors are mostly used only in the driver stage, to be followed in the output stage by transistors of the same polarity.

Fig. 3.5 shows the n-p-n output transistors in a push-pull configuration, driven by a complementary pair. This circuit configuration is known as quasi-complementary symmetry.

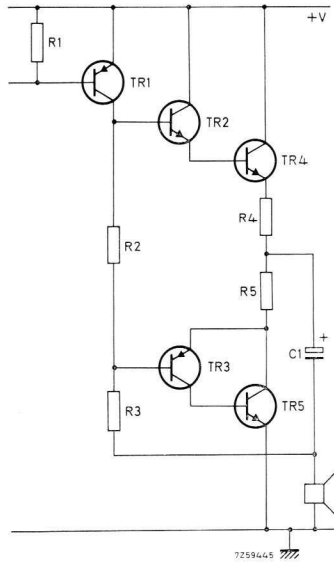

Fig. 3.5. Push-pull output stage using two n-p-n transistors driven by a complementary push-pull circuit (quasi-complementary symmetry).

3.3 Survey of Transistors for Power Amplifiers

3.3.1 TRANSISTORS FOR BATTERY-OPERATED EQUIPMENT

In a complementary symmetry stage the power output P_o is determined by the peak value of the collector current and the peak output voltage.

From Fig. 3.4 the output voltage is:

$$V_o = \frac{1}{2} [V_S - V_{CEK2} - V_{R6} - V_{R7} - V_{BE3} - V_{CEK1} - V_{R4}],$$

and it follows that the smaller V_{BE3} becomes the greater the output voltage and consequently the power output.

Comparing silicon ($V_{BE} = 650$ mV at 5 mA) with germanium (an AC188 has $V_{BE} = 115$ to 145 mV at 5 mA) it is clear that the lower value of base/emitter voltage of germanium transistors is preferred and a higher efficiency results, entailing a longer battery life. For battery-operated equipment germanium complementary output transistors are therefore preferred.

But there is another reason for preferring germanium complementary transistors in battery-operated equipment. In any complementary stage a small current flows under no-signal conditions to prevent cross-over distortion, and the d.c. setting is usually achieved by a small resistor connected between the bases of the complementary output transistors. As both germanium and silicon have a negative temperature coefficient effect, the base/emitter voltage V_{BE} decreasing with rise in temperature at about 2 mV/°C, the quiescent current is a function of the junction temperature of the transistors.

In Class-B output stages the junction temperature depends on the a.c. excursion, and so does the dissipation. Maximum dissipation occurs at approximately two-thirds of the sine-wave drive. Assuming that the maximum junction temperature is reached, with germanium transistors the value of V_{BE} would decrease to:

$$V_{BE} = (90 - 25) \times 2 = 130 \text{ mV.}$$

while for silicon transistors V_{BE} would decrease to:

$$V_{BE} = (175 - 25) \times 2 = 300 \text{ mV.}$$

With germanium transistors the quiescent current could rise, for example from 3 to 20 mA, but with silicon a quiescent current of 100 mA, or even higher, could be achieved. This is shown in Fig. 3.6.

It is obvious that in both cases the output stage must remain stable. With germanium transistors it is only a matter of selecting the correct-valued resistors, whereas with silicon transistors this method would seriously reduce the power output. As the latter is usually unacceptable, stabilizing diodes have to be employed, instead of less expensive resistors.

Germanium transistors are thus preferred for use in the output stages of battery-operated equipment.

Referring to Table 3.1 and comparing the AC127/128 with the AC187/188 it can be seen that the latter pair gives greater power output (up to about 3 W). If this level of power output is not required then obviously the AC127/128 complementary transistors may be used. However, there is a drawback in doing so. When complementary output transistors are used, direct coupling is employed from the driver stage. This means

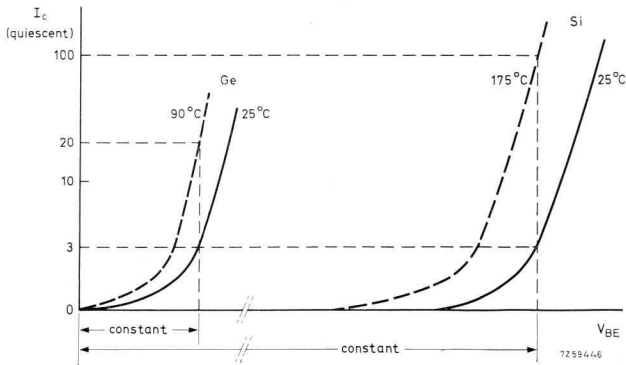

Fig. 3.6. Comparison between the quiescent currents of germanium and silicon transistors.

that the quiescent current setting of the driver stage must be such that the driver can deliver the base current of the output stage when the latter is equipped with minimum gain transistors. Hence the higher the minimum gain of the output transistors, the lower the quiescent current setting of the driver stage will be. Consequently battery life will be prolonged.

The robust AD161/162 transistors also feature high gain. This feature, combined with a low knee voltage and a low base/emitter voltage makes them almost ideal for car radio applications. However, the breakdown voltage level is such that in mains-powered applications attractive power output with good economy can be achieved. See Circuits 21 and 30.

Table 3.1. Germanium Complementary Transistors

type		envelope	ratings				$R_{th\ j-e}$ ($^{\circ}C/W$)	characteristics at $T_j = 25^{\circ}C$						
n-p-n	p-n-p		V_{CBO} (V)	V_{CEO} (V)	I_{CM} (A)	$T_j\ max$ ($^{\circ}C$)		h_{FE} at I_C (A)	$V_{CEK\ max}$ at I_C (V)	$I_{CBO\ max}$ at V_{CB} (μA)	V_{CB} (V)	$f_T\ typ$ (MHz)		
AC127		TO-1	32	12	0.5	90	110	40-175	0.3	1.0	0.5	10	0.5	2.5
	AC128			16	2.0		40	60-175		0.6	1.0		10	1.5
AC187		TO-1	25	15	2.0	90	40	100-500	0.3	0.8	1.0	100	25	5.0
	AC188									0.6		200		1.5
AD161		similar to TO-66	32	20	3.0	90	4.5	80-320	0.5	0.6	1.0	500	32	3.0
	AD162						$R_{th\ j-emb}$			0.4		200	32	1.5

Table 3.2. Silicon Driver Transistors

type		envelope	ratings				$R_{th\ j-emb}$ ($^{\circ}C/W$)	characteristics at $T_j = 25^{\circ}C$			
n-p-n/p-n-p			V_{CBO} (V)	V_{CEO} (V)	I_{CM} (A)	$T_j\ max$ ($^{\circ}C$)		h_{FE} at $I_C = 0.15\ A$	$I_{CBO\ max}$ (nA)	$f_T\ typ$ (MHz)	
BD135/136		TO-126	45	45	1.5	125	10	40-250	100	250/75	
BD137/138		TO-126	60	60	1.5	125	10	40-160	100	250/75	
BD139/140		TO-126	—	80	1.5	125	10	40-160	100	250/75	

Table 3.3. Silicon Power Transistors

type	envelope	ratings					$R_{\theta j-mb}$ ($^{\circ}C/W$)	characteristics at $T_j = 25^{\circ}C$ unless otherwise stated						
		V_{CBO} (V)	V_{CEO} (V)	V_{CER} (V)	I_{CM} (A)	T_{jmax} ($^{\circ}C$)		h_{FE} at I_C (A)	I_{CB0max} at V_{CB} (at $T_j = 200^{\circ}C$) (mA)	V_{CB} (V)	f_{hfe} (kHz)	f_T (MHz)		
n-p-n														
BD115	TO-39	245	180	245	0.2	200	12.5	> 22	0.05	0.55 typ.	200	—	—	145
BD181	TO-3	55	45	55	10	200	1.5	20-70	3	2	45	15 min. 20 typ.	—	—
BD182	TO-3	70	60	70	15	200	1.5	20-70	4	5	60	15 min. 20 typ.	—	—
BD183	TO-3	85	80	85	15	200	1.5	20-70	3	5	80	15 min. 20 typ.	—	—

3.3.2 SILICON DRIVER AND POWER TRANSISTORS

For higher power outputs n-p-n/p-n-p matched pairs are as attractive as they are for lower power outputs. However, germanium transistors have higher leakage currents than silicon and only metal can be used as the case material. Silicon transistors are therefore preferred for high power outputs, but at high power outputs it is rather costly to have n-p-n transistors with a well-matched p-n-p counterpart. The quasi-complementary configuration, however, combines the advantages of rugged power transistors of the same polarity in the output stage with economy of design.

The power output for a given loudspeaker impedance determines the supply voltage. The driver transistors listed in Table 3.2 may have rather high currents and breakdown voltages, and are therefore suitable for driving the output transistors over a wide range of loudspeaker impedances and power outputs.

It is a prerequisite of high power output transistors that they are rugged. This ruggedness has been economically achieved at a slight expense in the transition frequency. The resulting compromise makes the BD181, BD182 and BD183 ideal output transistors.

In order to achieve a good power bandwidth care should be taken to ensure that the impedance at the base side of the output transistors is low. Examples of this can be seen in the 15 W, 20 W, 25 W and 40 W amplifiers, Circuits 22, 23, 24 and 25 respectively. For use in the 40 W amplifier when an unstabilized supply is employed, the BD183 replaces the BD182. The BD183 transistor has a higher value of V_{CEO} but its characteristics are otherwise very similar. The BD115 high voltage transistor is not only of interest in applications involving a high supply voltage, but is well-suited to video as well as audio circuits. The characteristics of the silicon power transistors are given in Table 3.3.

3.4 Practical Layout of Audio Circuitry

3.4.1 GENERAL PRINCIPLES

The circuits described in this book are capable of high quality reproduction only if they are carefully constructed. Of special importance are the relative positions of input, output and power supply, including the earthing and screening arrangements.

On the magnetic pick-up position the input sensitivity is high and the overall voltage gain from the pre-amplifier input to the output of the power amplifier may well be of the order of 50000. It is therefore essential to keep the output separated and screened from the input, otherwise instability may occur. The magnetic field of the mains transformer may cause hum, so the transformer should be as remote as possible from the input.

3.4.2 EARTHING

Currents of several amps circulate in the power supply and output stages. No wiring carrying these currents should be included in the input circuit, otherwise hum or instability due to the low but nevertheless significant resistance of the wires will result. The paths of currents in the output stage and power supply are shown in Fig. 3.7.

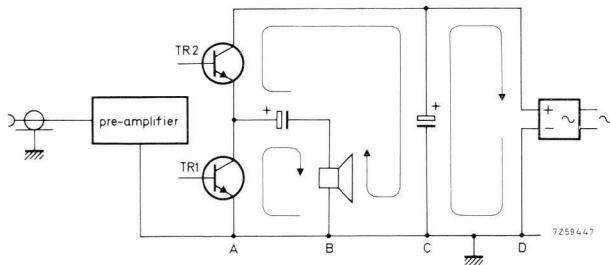

Fig. 3.7. Current paths in the power supply and output stage.

Between points A and B there is a voltage due to TR_1 ; between B and C a voltage due to TR_2 ; and between C and D a voltage due to the power supply. The input can be earthed at A, but not at B, C or D. In practice A, B, C and D would be combined at one common earthing point.

The earthing arrangements for stereo amplifiers are considerably more complex than for mono, since the single power supply and common earth for the signal inputs make it more difficult to avoid earth loops. The arrangement recommended for the 15 W, 25 W and 40 W amplifiers

described in this book is shown in Fig. 3.8. The arrangement given applies directly to the 40 W amplifier in which the output transistors are separately mounted.

It will be noted that the input sockets are earthed at the magnetic pick-up input, since this is the most sensitive. The negative supply rails for the pre-amplifier must be connected to the common earth at the pick-up input and a heavy gauge conductor used to connect this point to the power supply. The output transistors and speakers whose leads carry several amperes should be connected *directly* to a common earth

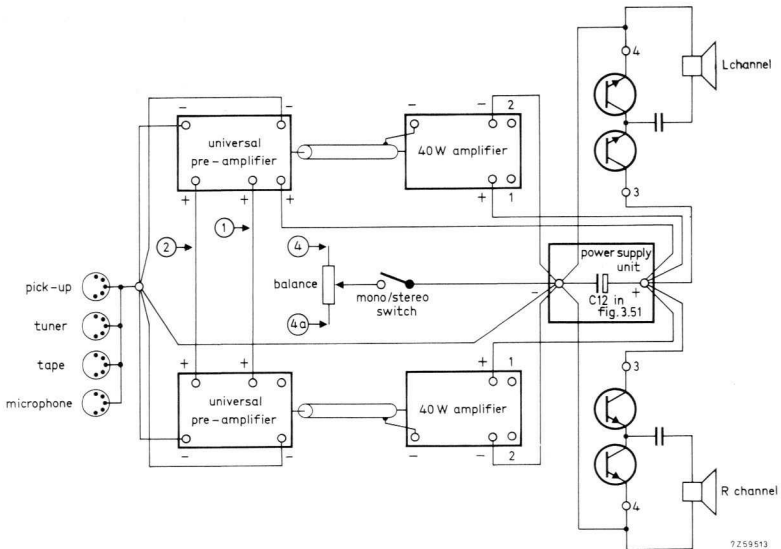

Fig. 3.8. Earthing arrangements for a stereo amplifier. Numbers in circles refer to connections in Fig. 2.34.

at the power supply negative terminal. Similarly, the positive lines should be individually connected to the power supply positive terminal. The R-channel pre-amplifier positive supply may be obtained directly from the L-channel, the latter incorporating the smoothing components, but again the connecting leads must be kept short. Heavy gauge connecting wire should be used throughout.

One exception to those recommendations which applies to the 40 W amplifier, is that if solid conductors of 1 mm dia, or greater, (22 SWG) are employed for the speaker leads and the power wiring for the output transistors, then these may be connected directly to the printed-wiring board of the output stage, instead of being taken to the power supply unit as they would have to be if thin stranded flexible wire was used, i.e. 3 to 1 and 4 to 2 in Fig. 3.8.

3.4.3 STRAY FIELDS

The input loop of a pre-amplifier is shown in Fig. 3.9. This loop should be as small as possible to prevent hum pick-up and it may also be necessary to screen the mains transformer. The magnetic field associated with the currents in the output stage may occasionally cause trouble.

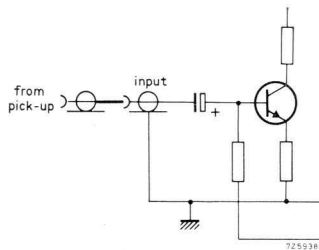

Fig. 3.9. Input loop of a pre-amplifier.

The remedy is to keep the output loops as small as possible, for example, by running the emitter and collector leads close together to minimise radiation. The input selector switch may also need screening.

3.4.4 POWER SUPPLIES

In addition to taking precautions against stray fields it is essential that the power supply, as well the conductors, has a low resistance. If the internal resistance of the power supply is high, the regulation will be poor and the output voltage may vary considerably with the signal. This, in turn, may give rise to instability.

3.5 Economical Transistor Power Amplifiers

3.5.1 CIRCUIT 17 – ONE WATT STEREO PICK-UP AMPLIFIER

Performance specification, each channel:

nominal power output	900 mW into 8 Ω load
sensitivity (1000 Hz) for $P_o = 900$ mW from 1000 pF source	600 mV
frequency response (−3 dB)	110 to 11 500 Hz at max. volume
tone control	−12 dB at 10000 Hz
nominal supply voltage	9 V
current consumption at $P_o = 900$ mW	160 mA

This circuit has been selected as an example of a design that uses the absolute minimum number of components yet ensures good performance. Four transistors are employed in a direct coupled circuit with a complementary symmetry output stage. Feedback is used to achieve a high

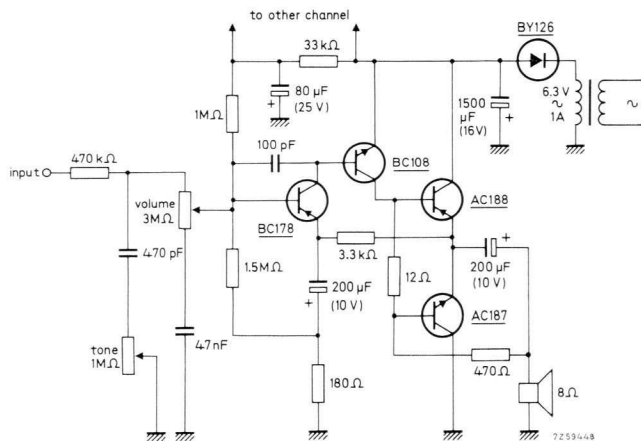

Fig. 3.10. One watt stereo pick-up amplifier circuit. Nominal supply voltage to transistors must not exceed 9 V.

input impedance, and a good low frequency response is obtained with a capacitive source such as a ceramic pick-up.

Only one channel is shown in Fig. 3.10, the simple power supply

consisting of a low voltage transformer with a single rectifier diode and reservoir capacitor common to both channels. The bias circuits for the input transistors of each channel are decoupled by a common RC filter network. The power transformer has a 6.3 V, 1 A secondary winding, its core size depending upon the ratio of r.m.s. signal power to music power required. The supply voltage to the transistors must not exceed 9 V because, since this is a low-cost circuit, no temperature compensating resistors are used in the output stage. A higher supply voltage and/or a lower speaker impedance will necessitate the use of an NTC resistor connected between the bases of the output transistors and also the use of emitter resistors.

Ganged toned controls, with separate or dual-concentric volume controls for each channel are recommended. In each case these may be of the linear type.

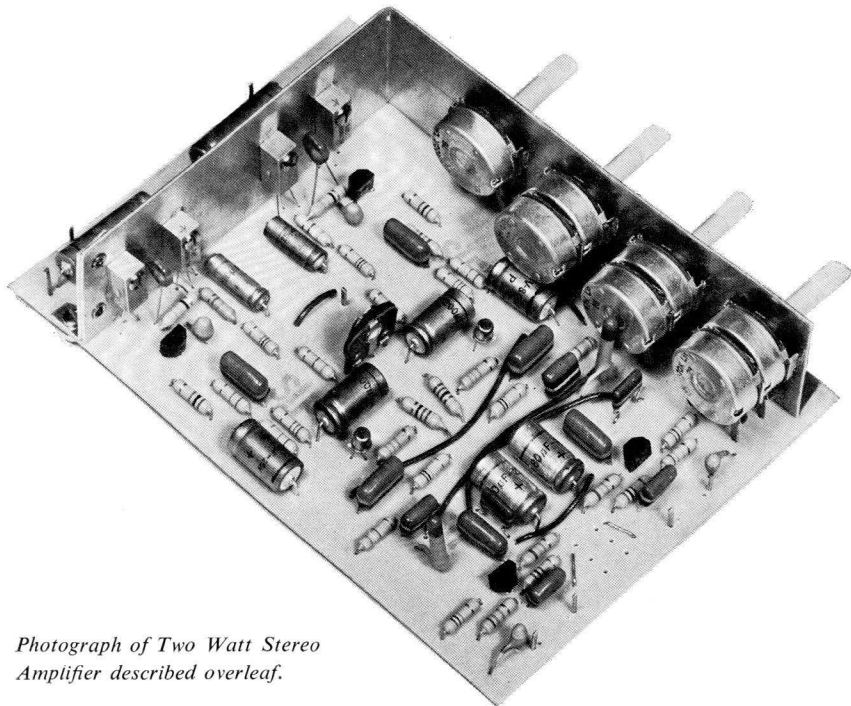

*Photograph of Two Watt Stereo
Amplifier described overleaf.*

3.5.2 CIRCUIT 18 – TWO WATT STEREO PICK-UP/RADIO AMPLIFIER

Performance specification, each channel:

nominal power output	2 W into 8 Ω load
sensitivity (1000 Hz) for $P_o = 2$ W	
pick-up (1000 pF)	320 mV
radio	70 mV
input impedance	130 k Ω
frequency response (-3 dB)	85 to 25000 Hz
total harmonic distortion at $P_o = 2$ W	2 %
nominal supply voltage	15 V
current consumption at $P_o = 2$ W	230 mA

This circuit is intended for use with stereo systems where a maximum power output of 2 W per channel is sufficient. Sensitivity is such that most types of ceramic pick-up and radio input levels can be accommodated.

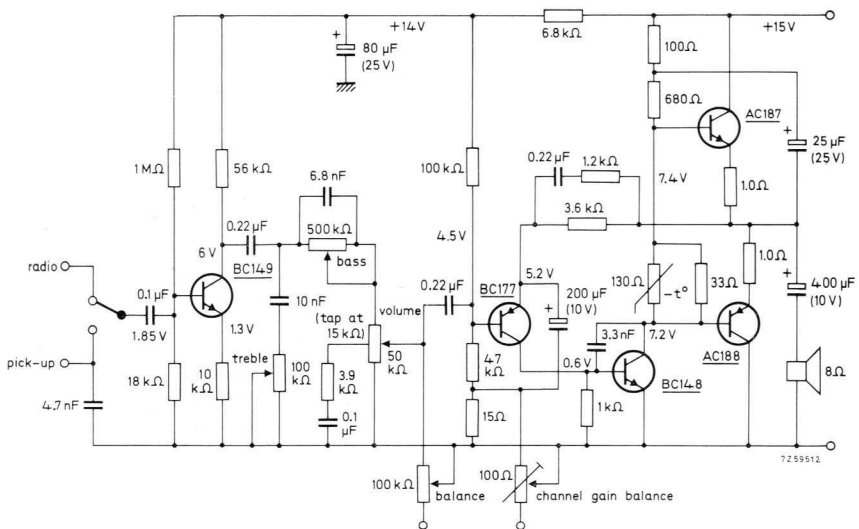

Fig. 3.11. Two watt stereo pick-up/radio amplifier circuit.

Tone controls are of the “cut” type, but bass boost derived from feedback gives the apparent effect that *both* bass boost and cut are available.

Fig. 3.11 shows the circuit of the amplifier. The effective input impedance

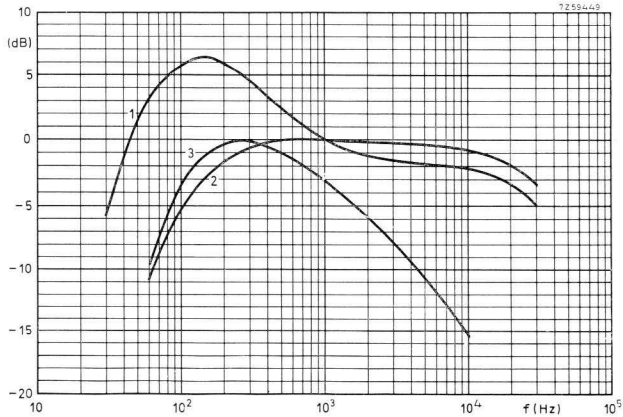

Fig. 3.12. Tone control characteristics of two watt stereo amplifier.
 Curve 1: maximum bass, treble flat;
 Curve 2: bass flat, treble flat;
 Curve 3: bass flat, maximum treble cut.

dance of the amplifier is 130 k Ω . The ceramic pick-up cartridge is capacitively loaded so that the high impedance of the cartridge at low frequency can be matched into a low impedance without loss of bass. Improved noise performance also results from the lowered input source impedance as seen by the input transistor.

Bass, treble and volume controls are located in the collector circuit of the input transistor, which simplifies the front panel wiring. Overload level is 25 dB above the input required for full amplifier output; this level is more than adequate to enable the volume control to be used at the output of the BC149, instead of the more usual position at the input.

The remainder of the amplifier is a conventional direct coupled amplifier with a complementary symmetry output stage using an AC187/AC188 matched pair of transistors. A negative temperature coefficient (NTC) resistor is used across the quiescent current stabilizing resistor to eliminate cross-over distortion at extremes of temperature.

Feedback from the output stage is applied to the emitter of the BC177. This is typically 12 dB at 1000 Hz. The d.c. feedback stabilizes the mid-point voltage of the output stage, while further frequency selective a.c. feedback is applied across the 3.6 k Ω resistor, resulting in a reduction in

feedback in the 100 Hz to 150 Hz region. This gives an effective bass boost of 6 dB at 120 Hz. Since the bass cut tone control has an approximate range of 12 dB at 130 Hz, the overall response is equivalent to a bass control variation of ± 6 dB at 120 Hz, relative to the 1000 Hz response.

The 3.3 nF capacitor connected between the collector and base of the driver transistor provides high frequency feedback to reduce the h.f. loop gain of the amplifier.

The 100 Ω preset control connected between the two channels provides a ± 4 dB variation in gain and thus can be used to align the centre-point of the balance control.

Heat-sinks are required only for the output transistors, approximately 4 sq in (25.8 cm²) of 1/16 in (1.6 mm) thick aluminium being recommended for each one. A multiple heat-sink carrying all four output transistors of a stereo version of this amplifier should therefore have an area of at least 16 sq in (103.2 cm²).

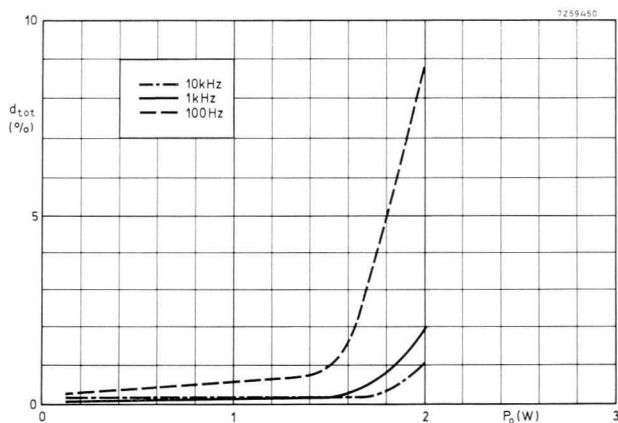

Fig. 3.13. Total distortion of two watt stereo amplifier.

The tone control characteristics of the amplifier are shown in Fig. 3.12, and the total distortion at three different frequencies for power outputs up to 2 W is shown in Fig. 3.13. For stereo applications, the printed-wiring board shown in Fig. 3.14 may be used.

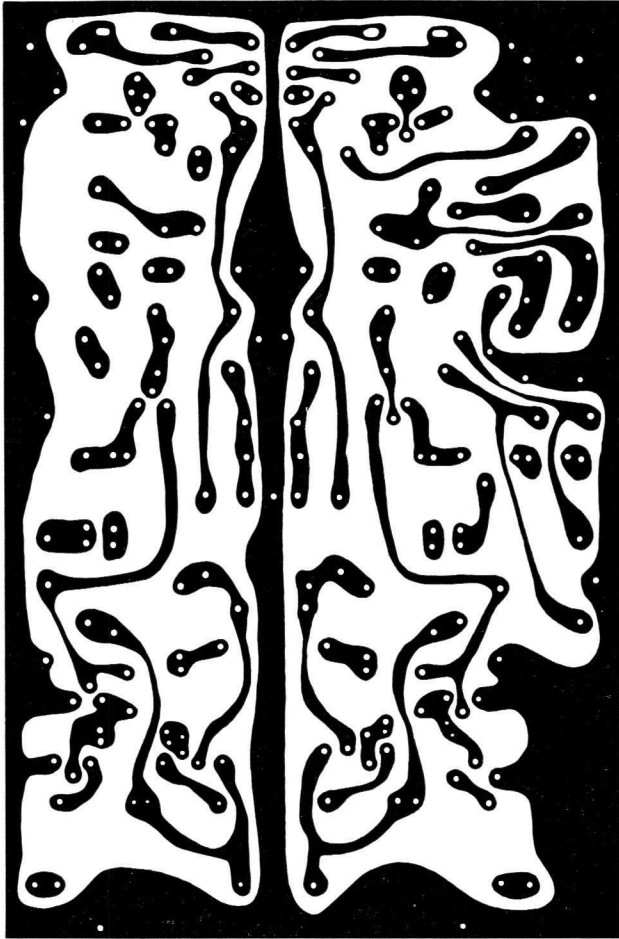

Fig. 3.14. Printed-wiring board for two watt stereo amplifier.

3.5.3 CIRCUIT 19 – FOUR WATT MONO CAR RADIO AMPLIFIER

Performance specification:

nominal power output	4 W into 4 Ω load
sensitivity (1000 Hz) for	
$P_o = 4$ W	48 mV
$P_o = 50$ mW	5 mV
input impedance	10 kΩ
frequency response (−3 dB)	200 to 20000 Hz
total harmonic distortion at $P_o = 4$ W	10 %
nominal supply voltage	14 V

The circuit of a direct coupled 4 W Class-B audio amplifier for use in a car radio is shown in Fig. 3.15. The amplifier uses an AD161/AD162

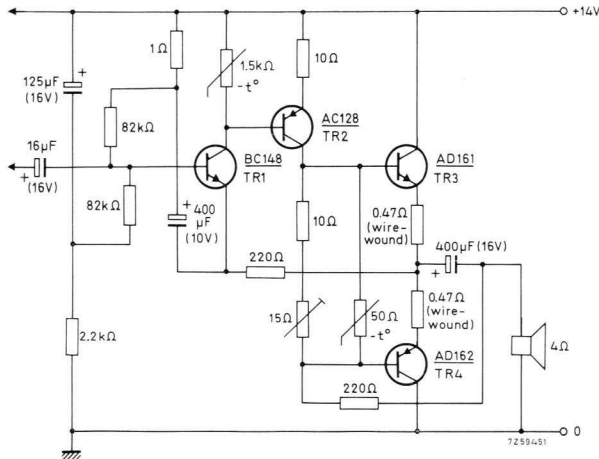

Fig. 3.15. Circuit of four watt mono car radio amplifier. All the transistors are mounted on one heat-sink which has a thermal resistance of $R_{th\ n-a} \leq 5.5$ °C/W.

complementary output pair, an AC128 driver transistor, and a BC148 or BC108 transistor as a first stage amplifier.

The amplifier is a conventional four-transistor circuit with one exception: the decoupling capacitor in the input stage is returned to the emitter of the BC148, instead of to chassis. This neutralizes the effect of ripple at the supply line and increases the input impedance.

The amplifier has been designed for operation in ambient temperatures from 20 to 70 °C, but its performance characteristics over a wide range of temperatures are given in Figs. 3.16 to 3.18.

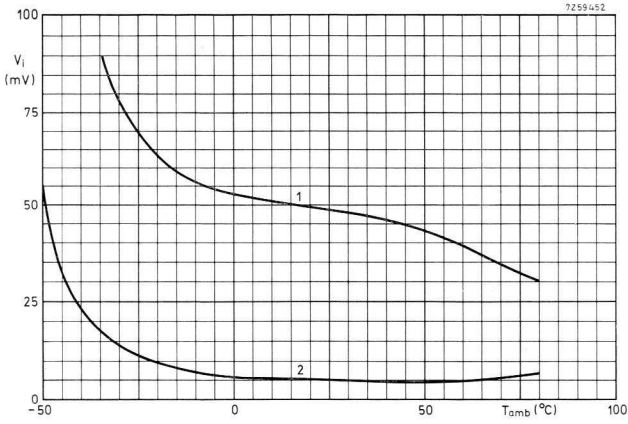

Fig. 3.16. Input sensitivity of four watt car radio amplifier at various ambient temperatures. Curve 1 for maximum power output at 10 % distortion; curve 2 for an output power of 50 mW.

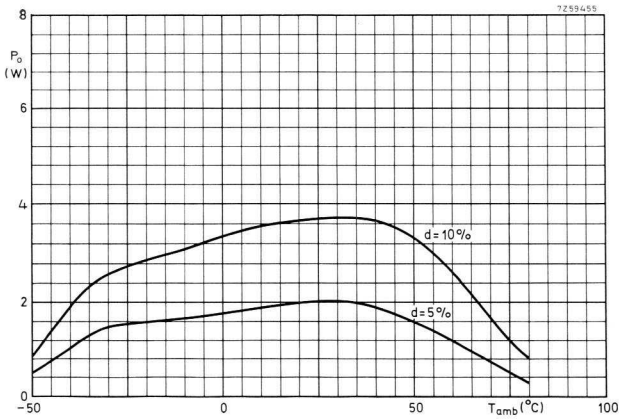

Fig. 3.17. Power output at two distortion levels as a function of the ambient temperature.

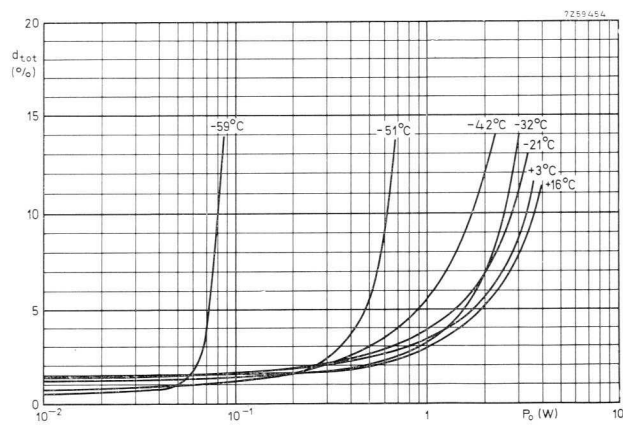
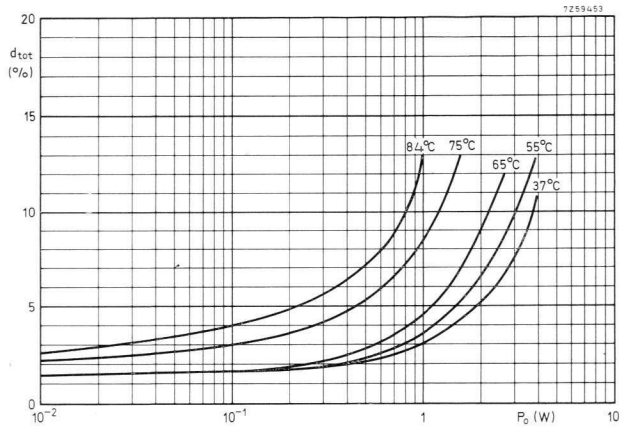

Fig. 3.18. Distortion as a function of output power at different ambient temperatures.

3.5.4 CIRCUIT 20 – FIVE/TEN WATT LOW-COST AMPLIFIER

Performance specification:

nominal power output	5 W into 8 Ω load 10 W into 4 Ω load
sensitivity (1000 Hz) for $P_o = 10$ W	
pick-up (1000 pF)	155 mV
radio	48 mV
input impedance	150 k Ω
frequency response (-3 dB)	40 to 30000 Hz
total harmonic distortion at $P_o = 10$ W	5 %
nominal supply voltage	24 V

This amplifier is a low-cost transformerless amplifier which will deliver 10 W into an 4 Ω load, or 5 W into an 8 Ω load at a total harmonic distortion of less than 5 % at 1000 Hz. It is intended for radio tuner and ceramic pick-up inputs. The circuit diagram is shown in Fig. 3.19.

The pre-amplifier is a BC149 transistor operating in the common-emitter mode. Its input impedance is made fairly low to reduce noise and make the stage more independent of component tolerances, particularly in the pick-up position where the transistor base is voltage driven using a capacitive divider to match a 1000 pF pick-up cartridge into a 150 k Ω input impedance.

A BC148 n-p-n silicon transistor is employed in the pre-driver stage, its bias point determining the mid-point voltage of the output stage.

The driver, TR_3 , is an AC128 high gain p-n-p germanium transistor operating in the common-emitter mode.

The output stage is directly coupled to the driver transistor and consists of the germanium transistor pair AD161/AD162 operated in Class-B complementary symmetry. The quiescent current of the output transistors is determined by R_{20} and R_{22} . Resistor R_{20} is a 15 Ω NTC used for thermally stabilizing the quiescent current. For best results, it should be mounted on the output transistor heat-sink. The quiescent current should be set at 15 mA by means of R_{22} .

Diode BY126 is used across the output to prevent the possibility of transistor breakdown due to negative voltage peaks produced by the inductance of the speaker on transients.

Treble cut is achieved by an RC network shunting the output of the pre-amplifier stage. Resistor R_8 controls the time-constant of the network, thus determining the degree of high frequency attenuation. At

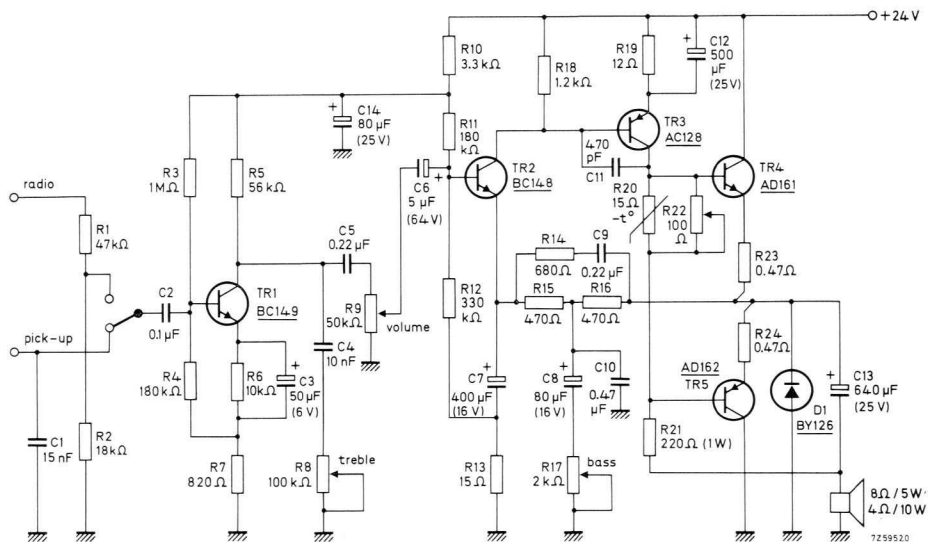

Fig. 3.19. Circuit of five/ten watt low-cost amplifier.

maximum treble cut, the network introduces 20 dB attenuation at 8000 Hz

Bass boost is provided by a bridged-T feedback network. When the time-constants of the two branches are equal, the attenuation of the whole network is independent of frequency. When the time-constant of the shunt branch increases, by reducing R_{17} , the attenuation of the lower frequencies increases. Since this network is in the feedback path, the lower frequencies are boosted. With the control in the maximum bass boost position, a boost of about 10 dB at 100 Hz is achieved.

The total distortion as a function of output power is shown in Fig. 3.20 and the frequency characteristic is shown in Fig. 3.21.

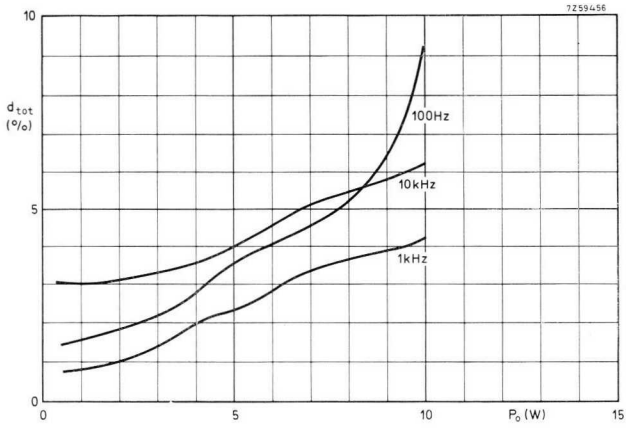

Fig. 3.20. Total distortion of five|ten watt amplifier.

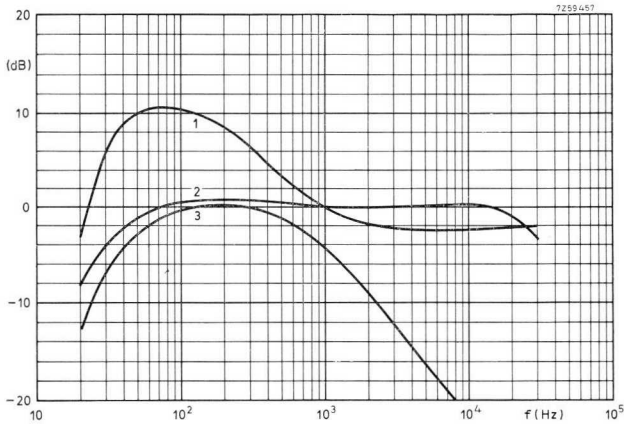

Fig. 3.21. Frequency response of the five|ten watt amplifier.

- Curve 1: maximum bass boost, treble flat;
- Curve 2: bass flat, treble flat;
- Curve 3: bass flat, maximum treble cut.

3.6 High Fidelity Power Amplifiers

3.6.1 CIRCUIT 21 – 8 WATT HI-FI AMPLIFIER USING AD161/AD162 OUTPUT TRANSISTORS

Performance specification:

nominal power output	8 W into 4 Ω load
sensitivity (1000 Hz) for	
$P_o = 8$ W	85 mV
$P_o = 50$ mW	6.7 mV
input impedance	330 k Ω
frequency response (–3 dB)	14 to 36000 Hz
total harmonic distortion at $P_o = 8$ W	1 %
unweighted signal/noise ratio (ref. $P_o = 8$ W)	76 dB
weighted signal/noise ratio (ref. $P_o = 8$ W)	86 dB
internal resistance at output socket	0.25 Ω
damping factor with 4 Ω speaker	16
nominal supply voltage	20 V
current consumption at $P_o = 8$ W	0.85 A

The block diagram of an eight watt hi-fi mono/stereo amplifier is shown in Fig. 3.22. Seven transistors are employed in the circuit which has a complementary symmetry output stage. A high input impedance is

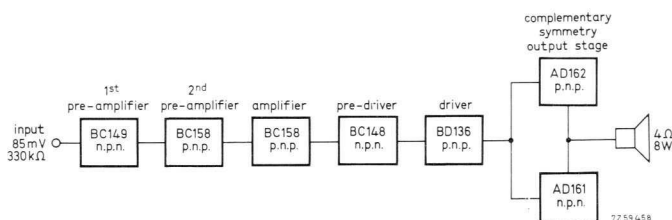

Fig. 3.22. Block diagram of eight watt hi-fi amplifier.

achieved by means of feedback and the amplifier meets the European Standard for high fidelity sound reproduction.

In the circuit diagram shown in Fig. 3.23, alternative networks may be connected between the emitter of TR_1 and the collector of TR_2 , depending upon whether the amplifier is required for mono or stereo use.

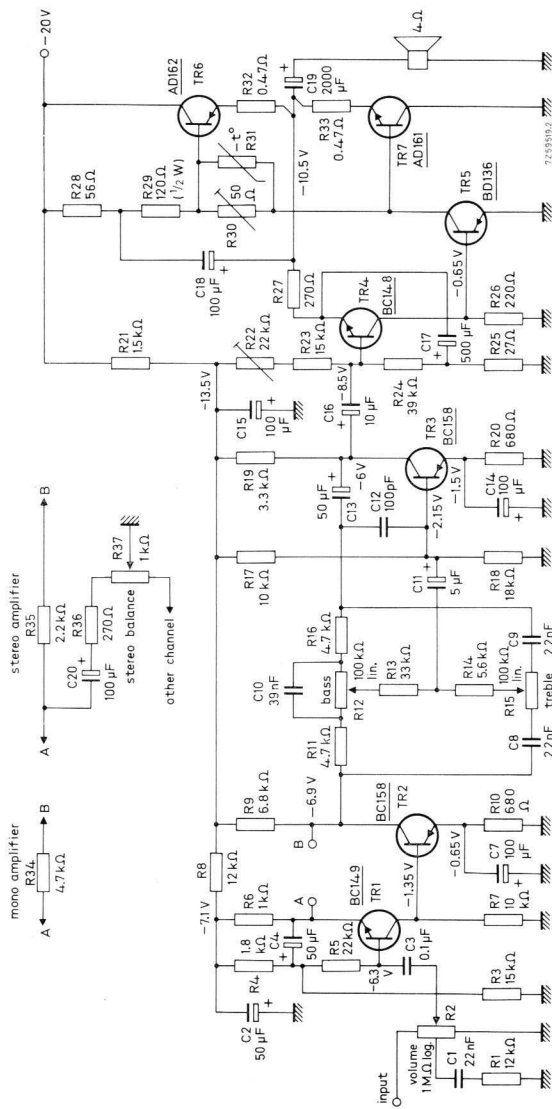

Fig. 3.23. Circuit diagram of eight watt hi-fi amplifier.

For stereo applications, the balance control network, shown separately, is connected between the emitters of the first pre-amplifiers of each channel.

The frequency characteristics of the amplifier are shown in Fig. 3.24. With the bass and treble controls flat, the response is linear from 100 Hz to 6000 Hz, and is within 1 dB of the response at 1000 Hz from 32 Hz to 18 000 Hz. It is only 2 dB down at 20 Hz and 1.2 dB down at 20 000 Hz.

The total distortion at 40 Hz, 1000 Hz, and 12 500 Hz is shown in Fig. 3.25. For 1% total harmonic distortion the output power at 40 Hz is 6.1 W, at 1000 Hz it is 8.1 W and at 12 500 Hz it is 7.8 W. The heat-sink for the output stage should be at least 115 cm² for 2 mm thick aluminium.

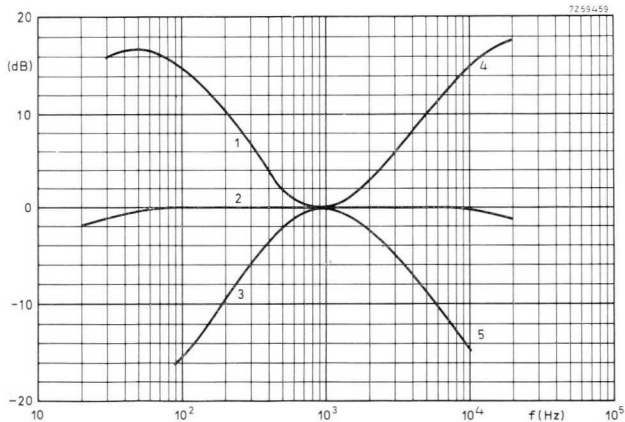

Fig. 3.24. Frequency response of the eight watt hi-fi amplifier.

- Curve 1: maximum bass boost;
- Curve 2: bass flat, treble flat;
- Curve 3: maximum bass cut;
- Curve 4: maximum treble boost;
- Curve 5: maximum treble cut.

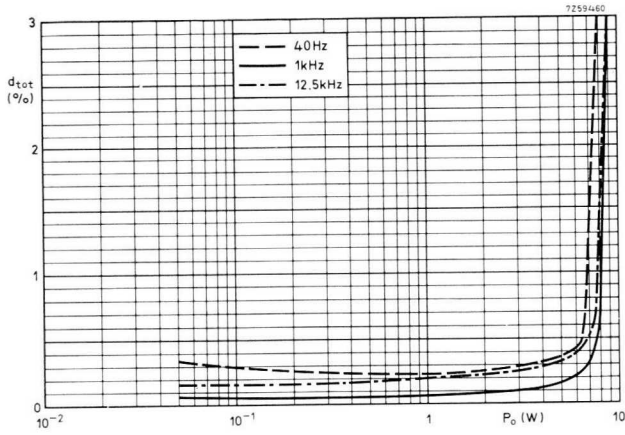

Fig. 3.25. Total distortion of the eight watt hi-fi amplifier.

3.6.2 CIRCUIT 22 – 15 WATT HI-FI AMPLIFIER USING BD181 OUTPUT TRANSISTORS

Performance specification:

nominal power output	15 W into 8 Ω load
sensitivity (1000 Hz) for $P_o = 15$ W	350 mV
input impedance	150 k Ω
frequency response (-0.5 dB)	14 to 100000 Hz
total harmonic distortion at $P_o = 15$ W	0.1 %
intermodulation distortion at $P_o = 15$ W	0.5 %
(measured with $f_1 = 250$ Hz and $f_2 = 8$ kHz where $V_{f1}:V_{f2} = 4:1$)	
unweighted signal/noise ratio (ref. $P_o = 50$ mW)	76 dB
internal resistance at output socket	0.05 Ω
damping factor with 8 Ω speaker	160
voltage feedback factor	350
nominal supply voltage	38 V
current consumption at $P_o = 15$ W	0.625 A

This amplifier fully complies with the European Standard for high fidelity sound reproduction. It will deliver 15 W r.m.s. output power into an 8 Ω load, Silicon transistors have been employed throughout and the amplifier uses BD181 power transistors in a quasi-complementary symmetry single-ended Class-B push-pull configuration. The block diagram given in Fig. 3.26 shows the general arrangement.

When used with the recommended Universal Pre-Amplifier described in Sub-section 2.3.8. the combination is highly suitable for all 15 W high fidelity equipments, particularly for 2×15 W stereo.

The circuit diagram is given in Fig. 3.27. A BC158B p-n-p transistor

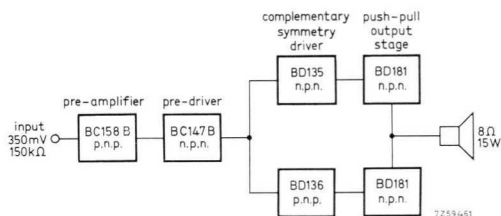

Fig. 3.26. Block diagram of 15 watt hi-fi amplifier.

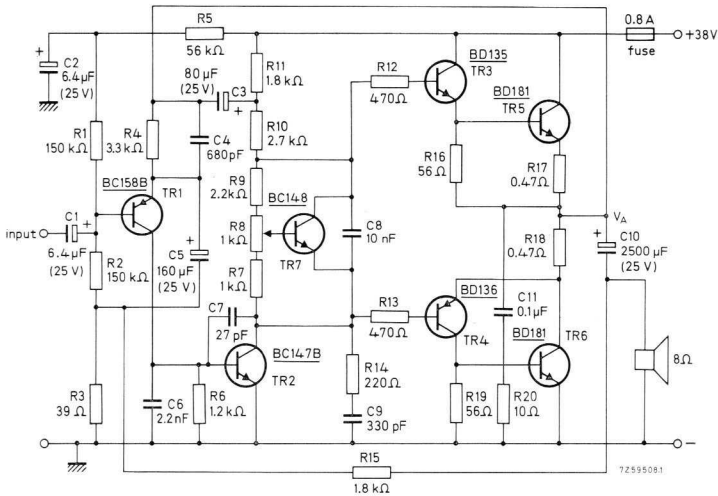

Fig. 3.27. Circuit of 15 watt hi-fi amplifier.

is employed in the pre-amplifier stage. Use of this high current gain transistor enables large amounts of feedback to be employed by means of resistors R_3 , R_4 and R_{15} . The transistor has an operating current of 0.5 mA. This stage also functions as a mid-point voltage stabilizer and for good stabilization R_4 must not have too high a value. On the other hand, for a high a.c. feedback factor from the speaker R_4 must be as high as possible with respect to R_{15} , since R_4 is in parallel with R_{15} . In this circuit a value of 3.3 k Ω for R_4 has been chosen. Due to the large feedback factor, the input impedance of the amplifier is equal to the value of R_1 , that is 150 k Ω .

The Class-A pre-driver stage uses an n-p-n BC147B which operates with a d.c. collector current of 4 mA. This is because the complementary driver transistors have a peak base current of 2.5 mA and there is a loss of 1.1 mA via resistor R_{10} . The maximum dissipation of the pre-driver transistor is 89 mW. To diminish the high frequency behaviour of this transistor an additional capacitance of 27 pF is connected between the collector and base of TR_2 .

The complementary driver transistors TR_3 and TR_4 are BD135 and BD136 respectively. These act as a phase inverter stage and have to

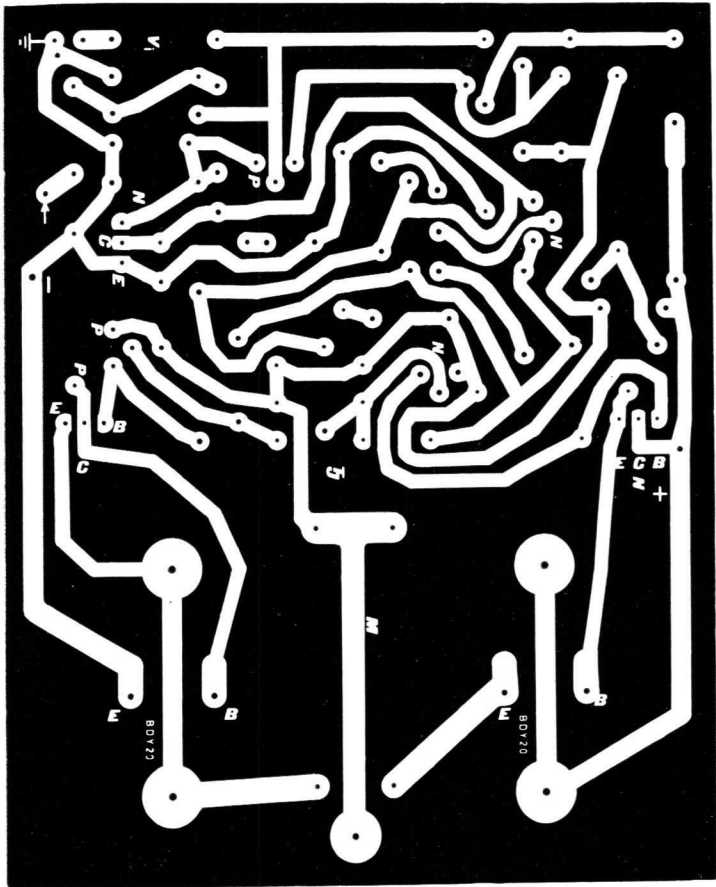

Fig. 3.28. Printed-wiring board for 15 watt hi-fi amplifier.

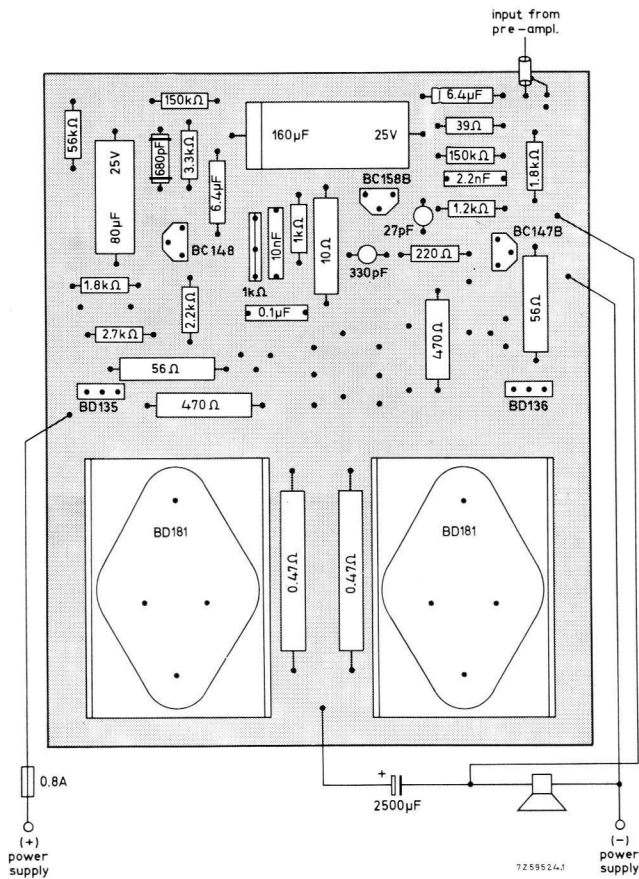

Fig. 3.29. Component layout of printed-wiring board for 15 watt hi-fi amplifier.

deliver the drive current for the output transistors and supply the currents through the resistors R_{16} and R_{19} connected between the base and emitter of each of the output transistors. The resistance value of R_{16} and R_{19} cannot be too high or the relatively low frequency behaviour of the BD181 output transistors will be affected (see Sub-section 3.3.2). In this amplifier R_{16} and R_{19} have a value of 56Ω .

At peak output, the maximum current which TR_3 has to deliver is 118 mA; TR_4 requires a somewhat lower current. In series with the bases of the driver transistors 470Ω resistors R_{12} and R_{13} are included for the short-circuit condition. The maximum drive current for the driver and output transistors is then limited when the output terminals are short-circuited. R_{12} and R_{13} are also important to limit the operation of the driver transistors in the overdrive condition when a complex load impedance is connected to the output terminals. Typical quiescent current for the driver transistors is about 10 mA, and in the worst case their dissipation becomes 310 mW.

The output stage uses two matched silicon power transistors BD181. These n-p-n transistors have a maximum power dissipation of 78 W at 25°C and a peak collector current of 10 A. The quiescent current of the output transistors is 40 mA, which can be adjusted by potentiometer R_8 . In the worst case the dissipation of each transistor is 6.5 W. The peak output current I_0 for $P_o = 15 \text{ W}$ into an 8Ω load R_L , is

$$I_0 = \sqrt{\frac{2 P_o}{R_L}} = 1.95 \text{ A.}$$

The peak output voltage for 15 W is 15.5 V. Resistors R_{17} and R_{18} provide thermal stability. The voltage losses in the upper part of the amplifier are due to the voltage drop across R_{17} , V_{BE} of TR_5 and V_{CEK} of TR_3 and together these amount to 3.5 V. Similarly, the voltage losses in the lower part are determined by the voltage drop across R_{13} , V_{BE} of TR_4 , V_{CEK} of TR_2 and the voltage drop across R_{18} . Again the total is 3.5 V. To guarantee 15 W output power with minimum devices the supply voltage at maximum power output must be equal to the sum of the total voltage losses and twice the peak output voltage excursion. This becomes

$$3.5 \text{ V} + 3.5 \text{ V} + 2(15.5 \text{ V}) = 38 \text{ V.}$$

The mid-point voltage V_A is 19 V.

To compensate the quiescent currents of the complementary drivers and output transistors against temperature and supply voltage variations, the base/emitter voltages of three transistors must be compensated. This can be done by three silicon diodes or by a transistor circuit which acts as a kind of zener diode. Due to its superior characteristics the transistor circuit has been incorporated in this amplifier. The circuit

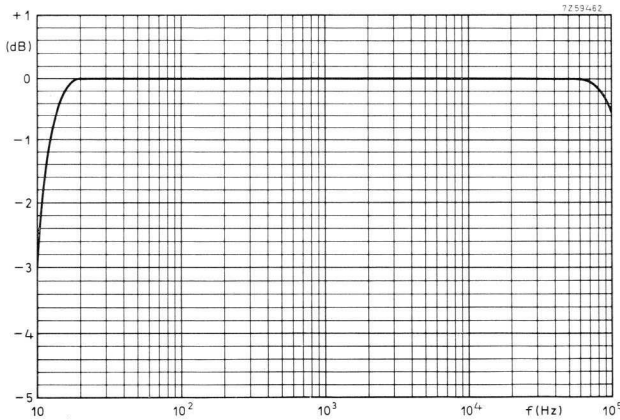

Fig. 3.30. Frequency response of 15 watt hi-fi amplifier. 0 dB = 6 dB below 15 watts.

comprises a plastic n-p-n transistor BC148, TR_7 , two resistors R_7 and R_9 , and a pre-set potentiometer R_8 with which the quiescent current can be adjusted. The nominal value of the collector/emitter voltage of TR_7 is approximately 1.8 V.

Fig. 3.28 shows the printed wiring board for the 15 W amplifier and the component layout is shown in Fig. 3.29. Interconnection of this amplifier with the power supply unit and the Universal Pre-amplifier has been dealt with in Section 3.4.

The frequency characteristic shown in Fig. 3.30 is linear from 20 Hz to 70000 Hz and drops to -0.5 dB with respect to the 1000 Hz response at 100 000 Hz.

Total harmonic distortion as a function of output power at the three frequencies 40 Hz, 1000 Hz and 12500 Hz is shown in Fig. 3.31. Inter-modulation distortion, measured with frequencies 250 Hz and 8000 Hz in the proportion 4:1, is 0.5% at maximum output power.

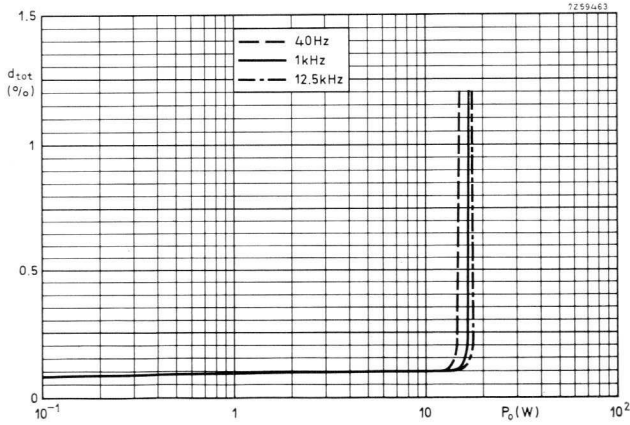

Fig. 3.31. Total harmonic distortion measured with an 8Ω load and a source resistance of $1 k\Omega$.

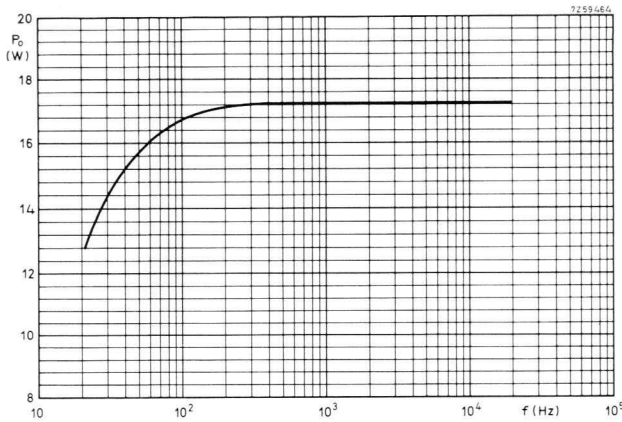

Fig. 3.32. Power bandwidth of 15 watt hi-fi amplifier.

The power bandwidth characteristic shown in Fig. 3.32 is for a total distortion of 1 %, measured with an 8Ω load and using a source impedance of $1 k\Omega$.

Protection against the short-circuiting of the speaker leads is by means of a fast acting fuse of 0.8 A rating. No higher rating should be used. Each output power transistor requires a heat-sink with an effective area of at least 12 cm^2 with a thickness of 2 mm.

3.6.3 CIRCUIT 23 – 20 WATT HI-FI AMPLIFIER USING BD181 OUTPUT TRANSISTORS

Performance specification:

nominal power output	20 W into 5 Ω load
sensitivity (1000 Hz) for	
$P_0 = 20$ W	210 mV
$P_0 = 50$ mW	11 mV
input impedance	100 k Ω
frequency response (–1 dB)	< 20 to > 20000 Hz
total harmonic distortion at $P_0 = 20$ W	0.1 %
unweighted signal/noise ratio (ref. $P_0 = 50$ mW)	66 dB
weighted signal/noise ratio (ref. $P_0 = 50$ mW)	81 dB
internal resistance at output socket	0.06 Ω
damping factor with 5 Ω speaker	83
nominal supply voltage	40 V
current consumption at $P_0 = 20$ W	1.2 A

The block diagram of a 20 Watt hi-fi amplifier is shown in Fig. 3.33.

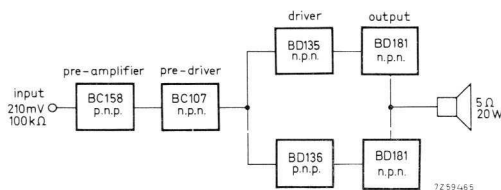

Fig. 3.33. Block diagram of 20 watt hi-fi amplifier.

Nine transistors and two diodes are employed in the circuit which has a quasi-complementary symmetry output stage. Two of the transistors, together with the diodes, provide protection against short circuiting of the output. The amplifier fully complies with the European Standard for high fidelity sound reproduction.

In the circuit diagram shown in Fig. 3.34 the short circuit protection network comprises the transistors TR_4 , TR_5 and diodes D_1 and D_2 . The operation of this circuit, which also applies to the 25 watt and 40 watt amplifiers, is described fully on page 108.

The frequency response and power bandwidth characteristics are shown in Fig. 3.35. The frequency response is virtually linear from 20 Hz to 20000 Hz.

Total distortion at 40 Hz, 1000 Hz and 12500 Hz is shown in Fig. 3.36. From 300 mW to 20 W output the distortion does not exceed 0.1 %.

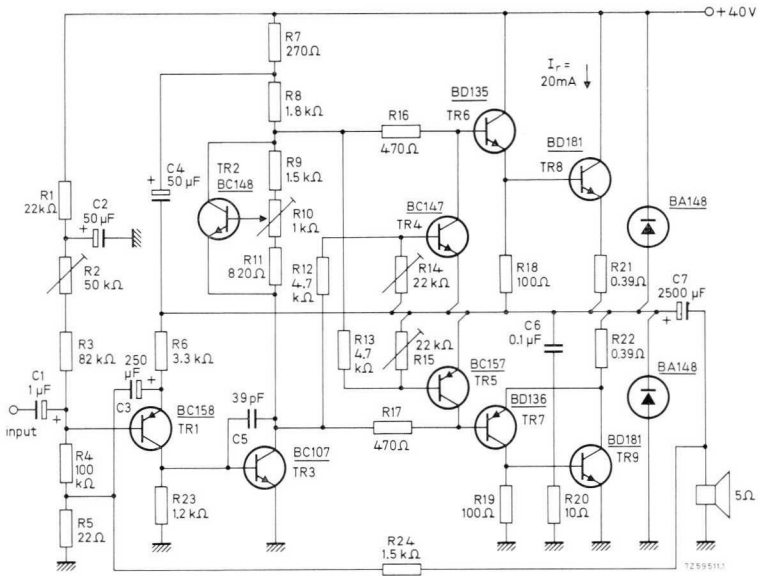

Fig. 3.34. Circuit diagram of 20 watt hi-fi amplifier. The output transistors are mounted on a 90 × 90 × 2 mm aluminium heat-sink.

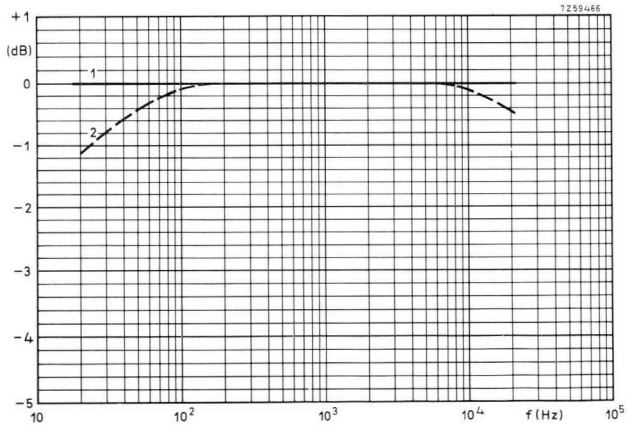

Fig. 3.35. Frequency response and power bandwidth characteristics of the 20 watt hi-fi amplifier.

Curve 1: amplitude/frequency, 0 dB = 6 dB below 31.2 W;
 Curve 2: power/frequency, 0 dB = 31.2 W.

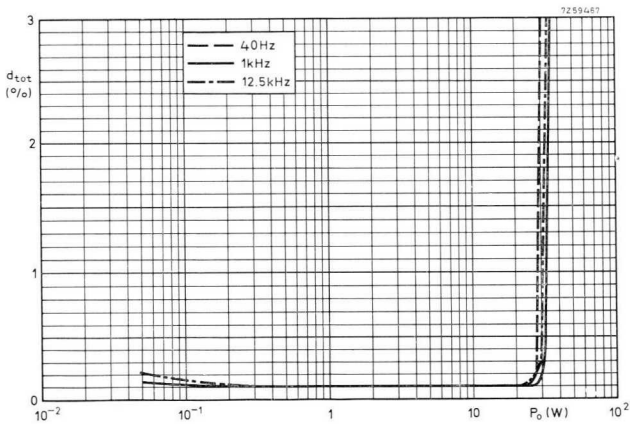

Fig. 3.36. Total distortion of the 20 watt hi-fi amplifier.

3.6.4 CIRCUIT 24 – 25 WATT HI-FI AMPLIFIER USING BD182 OUTPUT TRANSISTORS

Performance specification:

nominal power output	25 W into 8 Ω load
sensitivity (1000 Hz) for $P_o = 25$ W	350 mV
input impedance	150 k Ω
frequency response (-1 dB)	< 20 to 90000 Hz)
total harmonic distortion at $P_o = 25$ W	0.1 %
intermodulation distortion at $P_o = 25$ W (measured with $f_1 = 250$ Hz and $f_2 = 8$ kHz where $V_{f1} : V_{f2} = 4:1$)	0.6 %
unweighted signal/noise ratio (ref. $P_o = 50$ mW)	76 dB
internal resistance at output socket	0.05 Ω
damping factor with 8 Ω speaker	160
voltage feedback factor	370
nominal supply voltage	48 V
current consumption at $P_o = 25$ W	0.83 A

This amplifier complies fully with the European Standard for high fidelity sound reproduction and will deliver 25 W r.m.s. continuous sine-wave power into an 8 Ω load. Silicon transistors have again been used throughout and the amplifier employs BD182 power transistors in a quasi-complementary single-ended Class-B push-pull configuration.

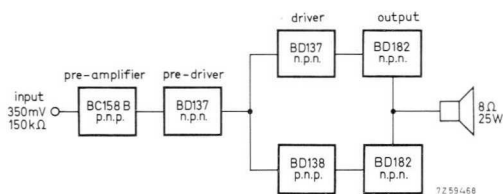

Fig. 3.37. Block diagram of the 25 watt hi-fi amplifier.

The block diagram given in Fig. 3.37 shows the general arrangement.

When used in conjunction with the recommended Universal Pre-amplifier described in Sub-section 2.3.8 the combination is very suitable for all 25 W high fidelity equipments, particularly 2×25 W stereo.

The circuit diagram is given in Fig. 3.38. A BC158B p-n-p transistor is employed in the pre-amplifier stage. Application of this high gain transistor enables large d.c. and a.c. feedback to be used by means of resistors R_3 , R_4 and R_{15} . The transistor has an operating current of

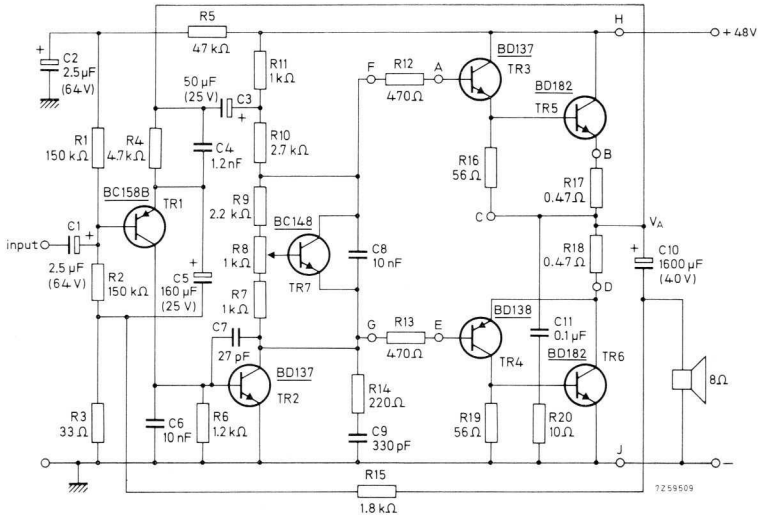

Fig. 3.38. Circuit diagram of the 25 watt hi-fi amplifier.

0.5 mA. This stage also functions as the mid-point voltage stabilizer. Due to the high feedback factor, the input impedance of the amplifier is equal to the value of R_1 , that is, 150 k Ω . In this respect, and also the operation of the remainder of the circuit, this amplifier is very similar to the 15 W amplifier previously described in Sub-section 3.6.2.

The Class-A pre-driver stage uses an p-n-p BD137 transistor TR_2 but a BC147 may be employed if a stabilized supply voltage is available.

The complementary driver transistors TR_3 and TR_4 are BD137 and BD138 respectively. At peak output, the maximum current which TR_3 has to deliver is 133 mA; TR_4 passes a somewhat lower current. Resistors R_{12} and R_{13} are again included to limit short-circuit and overdrive conditions. Typical quiescent current for the driver transistors is about 10 mA, and in the worst case their dissipation is 440 mW, so no heat-sinks are required for the driver transistors.

The output stage uses the robust BD182 power transistors in a matched pair. The quiescent current of the output pair is 40 mA, which can be adjusted by potentiometer R_8 . With no protection circuit the dissipation

in the worse case for each output transistor is 10.3 W. The peak output current I_o for $P_o = 25$ W into an 8Ω load is 2.5 A.

The peak output voltage for 25 W is 20 V. Voltage losses in the upper part of the output circuit are 3.5 V, and in the lower part are 4.5 V. To guarantee 25 W output power the supply voltage at maximum power output must be equal to the sum of the total voltage losses and twice the peak output voltage excursion. This becomes:

$$3.5 \text{ V} + 4.5 \text{ V} + 2 (20 \text{ V}) = 48 \text{ V}.$$

The mid-point voltage V_A is therefore 24 V.

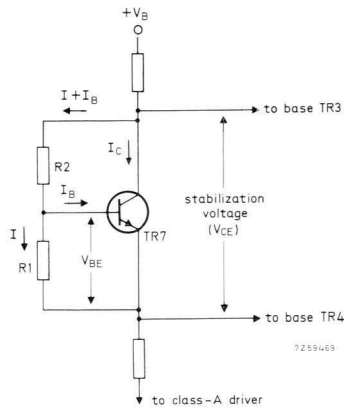

Fig. 3.39. Quiescent current stabilization network of the 25 watt hi-fi amplifier.

To compensate the quiescent currents of the drivers and output transistors against temperature and supply voltage variations, the base/emitter voltages of three transistors must be compensated. The circuit employed comprises a plastic n-p-n transistor BC148, TR_7 , two resistors R_7 and R_9 , and a pre-set potentiometer R_8 with which the quiescent current can be adjusted. The nominal value of the collector/emitter voltage of TR_7 is approximately 1.8 V.

Operation of the quiescent current stabilization network which is common to the 15 W, 20 W and 40 W amplifiers also, can be explained by reference to Fig. 3.39. In this circuit the stabilization voltage V_{CE}

is given by

$$V_{CE} = IR_1 + (I + I_B)R_2,$$

and

$$V_{BE} = IR_1.$$

The ratio V_{CE}/V_{BE} is given by:

$$\frac{V_{CE}}{V_{BE}} = \frac{IR_1 + (I + I_B)R_2}{IR_1}.$$

Since $I_B \ll I$, even with a BC148 with the lowest gain, the ratio V_{CE}/V_{BE} becomes:

$$\frac{V_{CE}}{V_{BE}} = \frac{R_1 + R_2}{R_1} = \frac{R_{CE}}{R_{BE}}.$$

This expression shows that a variation of V_{BE} produces a variation in V_{CE} depending on the ratio R_{CE}/R_{BE} , so

$$\Delta V_{CE} = \frac{R_{CE}}{R_{BE}} \cdot \Delta V_{BE}.$$

The temperature dependency of V_{CE} is thus given by:

$$\Delta V_{CE}/^{\circ}\text{C} = \frac{R_{CE}}{R_{BE}} \cdot \Delta V_{BE}/^{\circ}\text{C}.$$

This temperature dependency of V_{CE} must be made equal to the V_{BE} temperature dependencies of TR_3 , TR_4 and TR_5 which have to be compensated. V_{BE} has a similar value (about 2 mV/ $^{\circ}\text{C}$) in each case, and so by arranging that the ratio $R_{CE}/R_{BE} = 3$, quiescent current stabilization can be easily achieved. It will be seen from the circuit diagram in Fig. 3.38 that $R_9 = 2.2 \text{ k}\Omega$, $R_8 = 1 \text{ k}\Omega$ and $R_7 = 1 \text{ k}\Omega$. R_8 may be adjusted to make $R_{BE} = 1.4 \text{ k}\Omega$ when, since $R_{CE} = R_7 + R_8 + R_9 = 4.2 \text{ k}\Omega$, their ratio is 3.

Supply voltage variations will change the d.c. setting of the Class-A pre-driver stage, causing a small variation in the emitter/base voltage of transistor TR_7 , but the quiescent current for the output transistors will

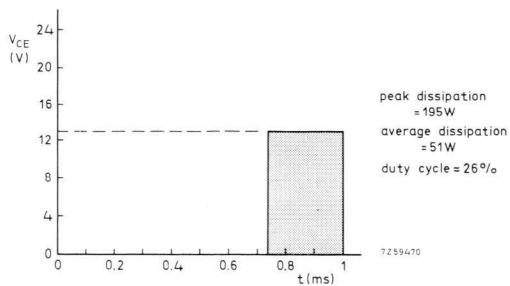
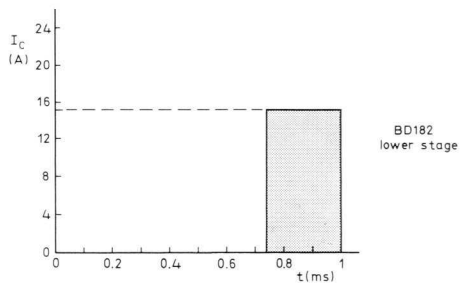
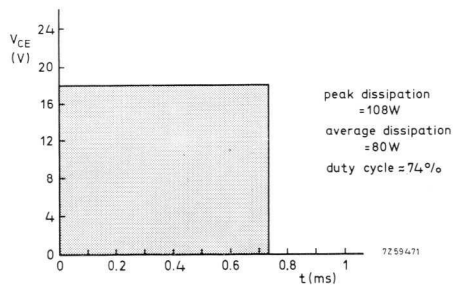
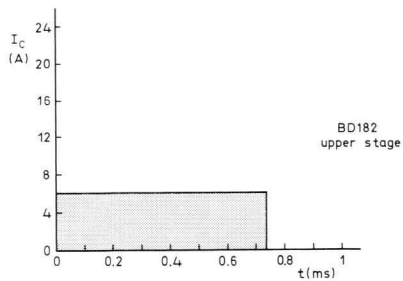

Fig. 3.40. Short-circuit conditions of the 25 watt amplifier without protection.

hardly be affected. The stabilizing transistor must not be mounted on the heat-sink of the output transistors otherwise over-compensation will occur.

Short-circuiting of the output terminals produces heavy currents in the output and complementary driver transistors. The immediate effect of short-circuiting does not, in itself, present a problem. Although the feedback falls off and a very small input signal will cause a large overdrive, the output transistors have an enormous margin before their ratings are exceeded. Fig. 3.40 shows the short-circuited conditions of the BD182's, from which the following values can be obtained:

	upper BD182	lower BD182
	TR_5	TR_6
Peak collector current	6 A	15 A
Peak collector/emitter voltage	18 V	13 V
Duty cycle	74 %	26 %
Peak power dissipation	108 W	195 W
Average power dissipation	80 W	51 W

Now the upper BD182 should have a total thermal resistance of:

$$R_{th \text{ tot}} = \frac{T_{j \text{ max}} - T_{amb}}{P_{av}} = \frac{200 - 50}{80} = 1.9^\circ\text{C/W}.$$

This cannot be realised, because the transistor already has a thermal resistance from junction to case of 1.5°C/W , so some form of short-circuit limiting is essential for temperature reasons.

Two short-circuit protection networks are shown in Fig. 3.41. The letters used to indicate connections correspond with those at appropriate points on the circuit of Fig. 3.38. Consider Fig. 3.41(a) where Protection Circuit I is shown. This circuit uses two transistors BC148 and BC158 which are normally in the *off* condition. When a sufficiently high a.c. current is flowing through R_{17} and R_{18} (Fig. 3.38), the base/emitter voltage is becoming more positive for the BC148 and more negative for the BC158. At a certain voltage level, depending upon the a.c. current through R_{17} and R_{18} and the base voltage-dividers $R_{21}(I)/R_{22}(I)$ and $R_{23}(I)/R_{24}(I)$ both transistors switch on. Due to the low *on* resistance of the transistors, the a.c. drive current for the complementary driver transistors is limited to a certain level, controlled by the preset potentiometers $R_{21}(I)$ and $R_{24}(I)$. For additional safety, two fast-acting 1.6 A fuses are inserted. The short-circuit and overdrive conditions of the complementary driver and output transistors is shown in Fig. 3.42,

from which the dissipation of the output transistors can be calculated.

Average supply current	1.42 A	P_{npn} driver	= 1.63 W
Regulated supply voltage	48 V	P_{pnp} driver	= 2.6 W
Supply power	68.16 W	P_{npn} output	= 21 W
		P_{pnp} output	= 42 W
			<hr/> 67.23 W

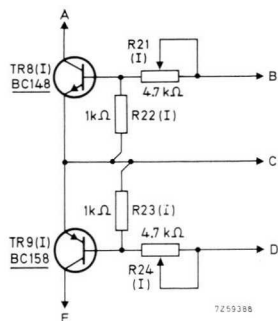

(a) protection circuit I

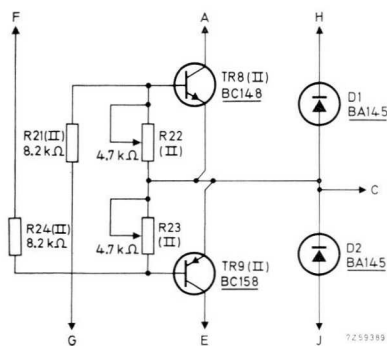

(b) protection circuit II

Fig. 3.41. Short-circuit protection networks for 25 W amplifier.

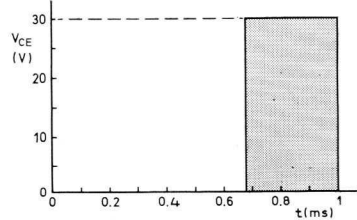
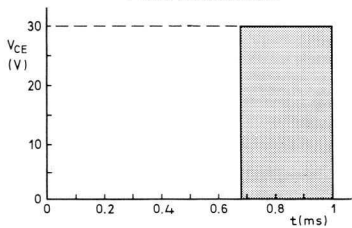
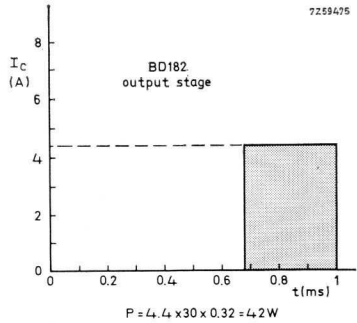
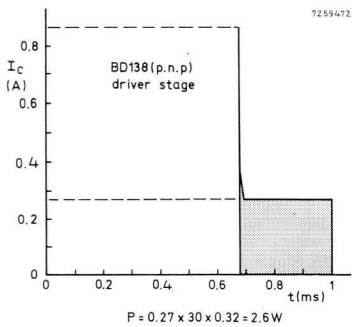
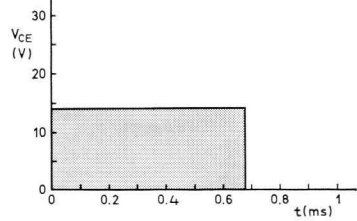
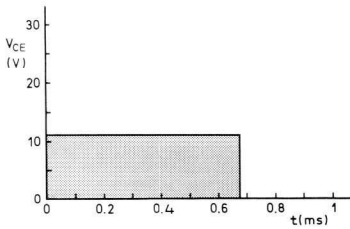
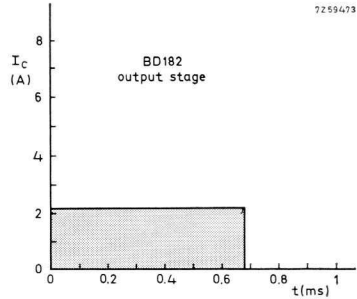
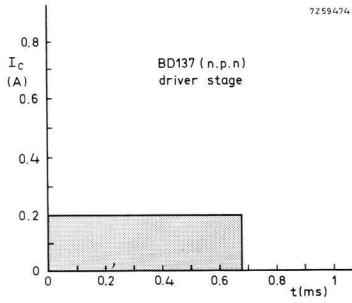

Fig. 3.42. Short-circuit conditions with protection circuit I.

Total dissipation is roughly 68 W and a very large heat-sink is therefore required with this method of protection. Due to the high dissipation under short-circuit conditions, R_{17} and R_{18} must be 10 W types. Without short-circuit protection 2 W types may be used for these resistors, and a 2 mm thick bright aluminium heat-sink measuring 4.5×4.5 cm employed for the output transistors.

Short-circuit Protection Network II shown in Fig. 3.41(b) is similar to that used on the 20 W amplifier described earlier. The circuit uses plastic transistors BC148/BC158, requiring at the same time two BA145 diodes, but no fuses. Under normal operating conditions the transistors are again in the *off* condition. When the output current increases due to short-circuiting, the base potentials of the complementary driver transistors change very rapidly with reference to the d.c. mid-point voltage V_A . At a certain level the protection transistors switch *on* and the a.c. drive currents for the driver and output transistors flow through the protection transistors instead. The level at which the protection network starts to operate is adjusted by pre-set potentiometers $R_{22}(II)$ and $R_{23}(II)$.

When the output terminals are not short-circuited, but when a complex load condition exists and strong overdrive is present, the output current becomes higher than the maximum sine-wave excursion and the protection circuit conducts. The output and driver transistors are then reversed-biased due to the presence of the protection transistors and the energy in the complex load. If no additional protection was provided the output and driver transistors could be damaged due to the reverse voltage breakdown and to overcome this two BA145 diodes are connected in reverse across the output transistors.

Although Circuit II requires two diodes more than Circuit I, it has the advantage that the same size of heat-sinks as are used in the unprotected amplifier may be employed, that is 4.5×4.5 cm.

The short-circuit protection networks are adjusted as follows:

Protection Circuit I

- (a) Connect a 2 Ω , 50 W resistor across the output.
- (b) Apply a 1000 Hz signal to the input, of sufficient amplitude to give a 2 V peak signal across R_{18} , ($\approx 4 \text{ A} \times 0.47 \Omega$), measured with an oscilloscope.
- (c) Adjust $R_{24}(I)$ to cause clipping to commence at 1.9 V.
- (d) Repeat (b) and (c) adjusting $R_{21}(I)$ and measuring across R_{17} .

Protection Circuit II

- Set $R_{22}(II)$ and $R_{23}(II)$ to mid-position.
- Connect a $2\ \Omega$, $20\ W$ resistor across the output.
- Connect an oscilloscope across R_{17} , and preferably, if it is a double-beam instrument, across R_{18} as well.
- Apply a $1000\ \text{Hz}$ signal to the input, of sufficient amplitude to measure $2\ \text{V}$ peak across R_{17}/R_{18} .
- Adjust $R_{22}(II)$ for clipping at $1.9\ \text{V}$ across R_{17} as shown in Fig. 3.43(a).
- Adjust $R_{23}(II)$ to give protection as indicated by the voltage measured across R_{18} , shown in Fig. 3.43(b).

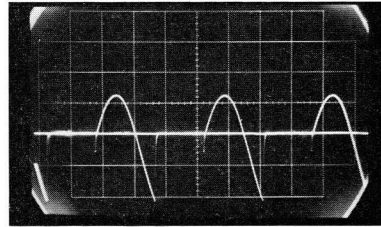
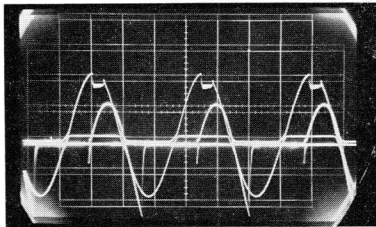
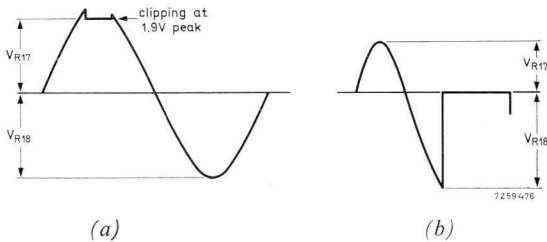

Fig. 3.43. Adjustment of protection circuit II. In the oscillogram at the left both waveforms are superimposed.

Fig. 3.44 illustrates the printed-wiring board for the $25\ \text{W}$ amplifier. The component layout is shown in Fig. 3.45. Interconnections between this amplifier, the power supply unit and the Universal Pre-amplifier

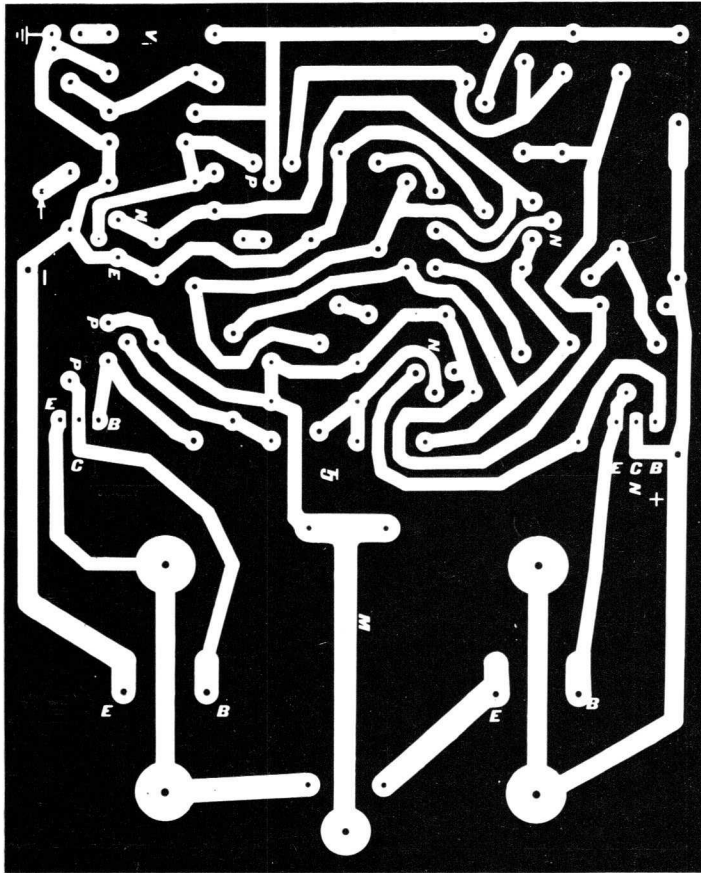

Fig. 3.44. Printed-wiring board for 25 watt hi-fi amplifier.

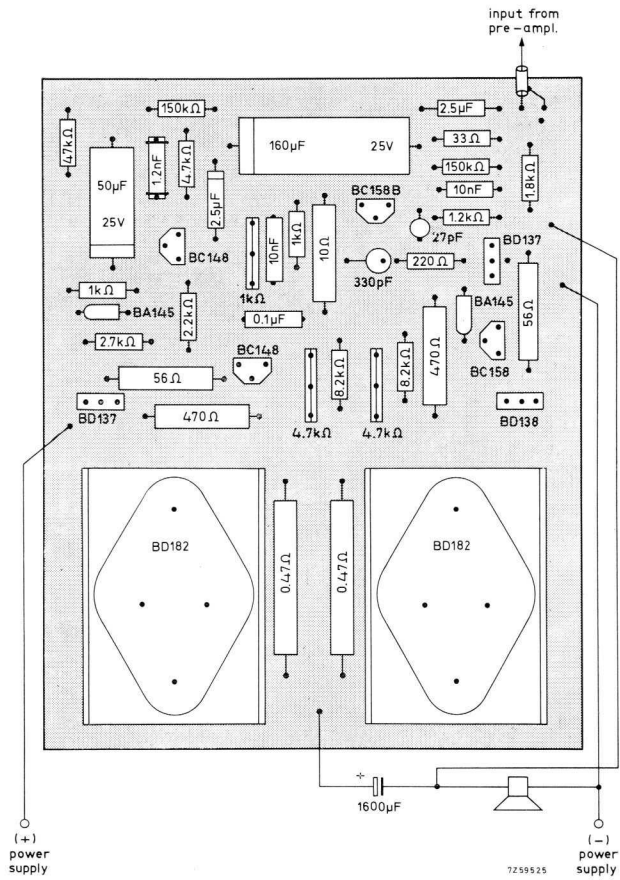

Fig. 3.45. Component layout of printed-wiring board for 25 watt hi-fi amplifier employing protection circuit II.

have been dealt with in Section 3.4. Short-circuit Protection Network II components are included on the printed-wiring board and can be clearly seen in the photograph of the completed amplifier on page 44.

The frequency characteristics shown in Fig. 3.46 is within 1 dB of the

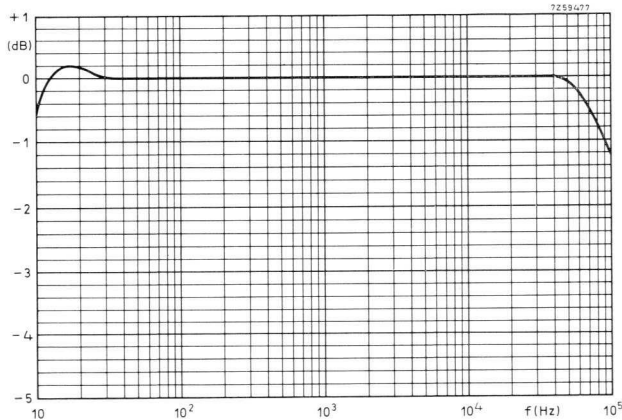
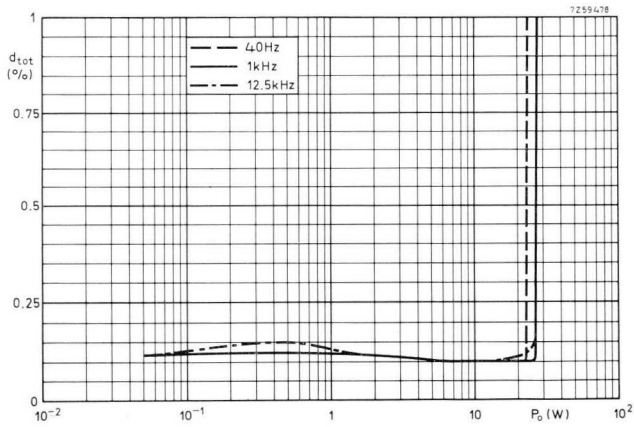

Fig. 3.46. Frequency response of 25 watt hi-fi amplifier. 0 dB = 6 dB below 25 watts.

response at 1000 Hz from below 20 Hz to 90000 Hz. Total harmonic distortion as a function of output power at the three frequencies 40 Hz, 1000 Hz and 12500 Hz is shown in Fig. 3.47(a) for an amplifier without short-circuit protection or with Protection Circuit II, and in Fig. 3.47(b) for when Protection Circuit I is used. Up to 25 W output the total harmonic distortion is approximately 0.1 % with intermodulation distortion at 0.6 % for amplifiers employing either no protection network at all, or using Protection Circuit II. If Protection Circuit I is used, intermodulation distortion rises to 1.2 %. Intermodulation distortion is measured with the frequencies 250 Hz and 8000 Hz in the proportion of 4:1

The power bandwidth characteristic shown in Fig. 3.48 is for a total distortion of 1 %, using an 8 Ω load and a source impedance of 1 k Ω .



(a) without short-circuit protection,
or with Protection Circuit II

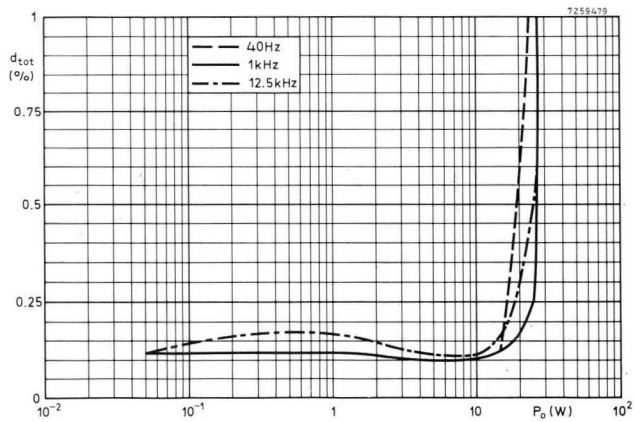

(b) with Protection Circuit I

Fig. 3.47. Total harmonic distortion of 25 watt amplifier.

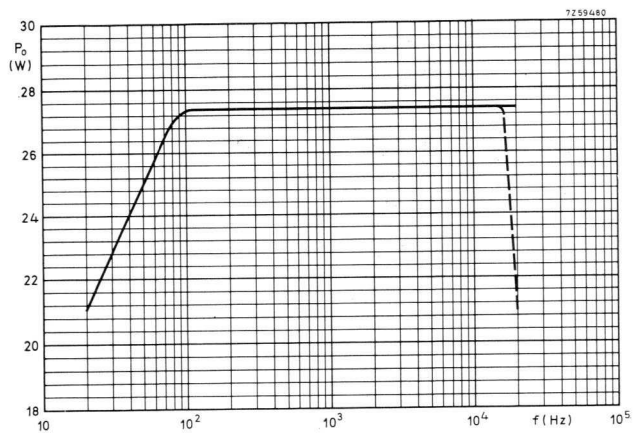
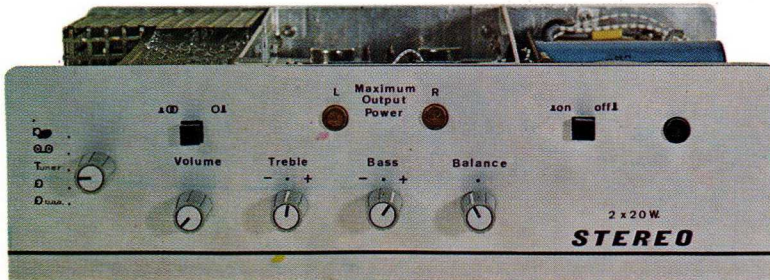

Fig. 3.48. Power bandwidth characteristic of 25 watt amplifier. Full line — without short-circuit protection, dotted line — with protection circuit I.

Construction of a 20 + 20 W Hi-fi Stereo Amplifier

The 20 + 20 W hi-fi stereo amplifier pictured here utilizes two Universal Pre-amplifiers (Circuit 8), two 25 W Power Amplifiers (Circuit 24) and an Overdrive Indicator (Circuit 26). BD182 silicon power transistors are employed in a quasi-complementary output circuit.

The unit is divided into three sections. On the left of the unit the inputs are taken from the sockets at the rear, via a source selector switch, to the left and right channel pre-amplifiers. In the centre are the two 25 W power amplifiers together with the overdrive indicator circuit. At the right are the power supply components.



In the picture of the front panel shown here, the source selector switch is at the far left and the mono/stereo switch is above the volume control. Two 24 V, 0.02 A lamps, centrally mounted, are used in the overdrive indicator circuit. The on/off switch and the pilot lamp are on the far right.

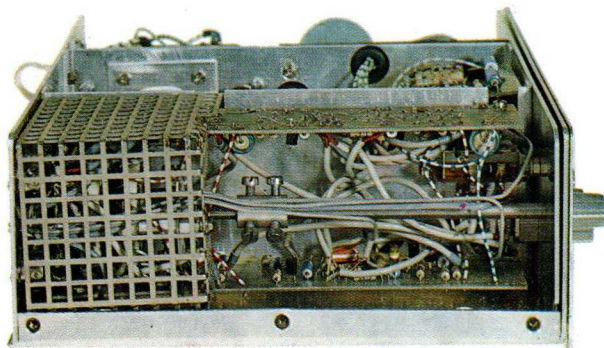

The left-hand side view of the stereo amplifier given here clearly shows the positions of the two pre-amplifiers and also the screen which encloses the selector switch. Wiring runs are kept as short as practicable without the risk of hum pick-up.

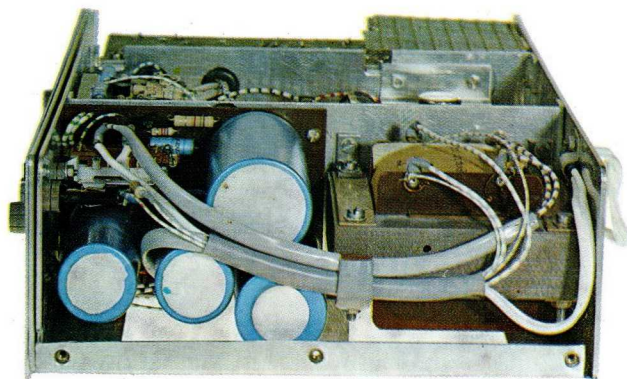

This picture shows the right-hand side of the amplifier. The mains transformer at the rear has a secondary voltage of 37 V. The smoothing capacitors of 2500 μF and 1600 μF can be seen, whilst the two smaller electrolytics are the output capacitors. Four BY126 bridge-connected diodes provide the supply voltage.

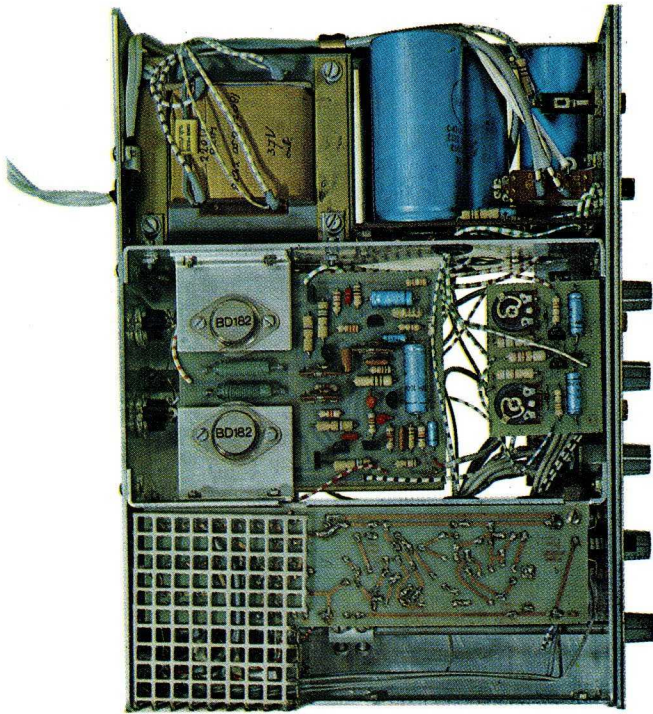

The plan view shown here clearly illustrates the simple and compact layout. The sheet-metal heat-sinks of the output transistors are screwed to the main chassis members and ample heat dissipation is obtained. The overdrive circuit components are mounted on the small printed wiring board, centrally located, behind the front panel.

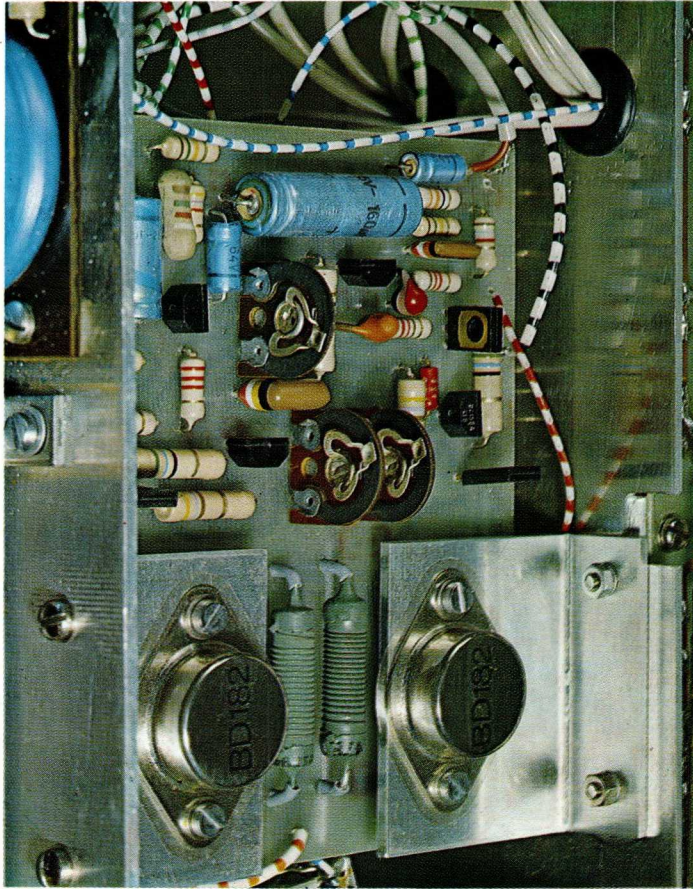

Close-up of the left-channel power amplifier. Protection Circuit II has been used and the components can be easily indentified. The 0.47Ω emitter resistors are fitted between the BD182 output transistors.

3.6.5 CIRCUIT 25 – 40 WATT HI-FI AMPLIFIER USING BD182 OUTPUT TRANSISTORS

Performance specification:

nominal power output	40 W into 8 Ω load
sensitivity (1000 Hz for $P_o = 40$ W)	440 mV
input impedance	150 k Ω
frequency response (-0.5 dB)	12 to 95000 Hz
total harmonic distortion at $P_o = 40$ W	0.2 %
intermodulation distortion at $P_o = 40$ W (measured with $f_1 = 250$ Hz and $f_2 =$ 8 kHz, where $V_{f1}:V_{f2} = 4:1$)	0.8 %
unweighted signal/noise ratio (ref. $P_o = 50$ mW)	78 dB
internal resistance at output socket	0.05 Ω
damping factor with 8 Ω speaker	160
voltage feedback factor	280
nominal supply voltage	60 V
current consumption at $P_o = 40$ W	1.1 A

The 40 W amplifier described here is very similar in design to the 25 W amplifier discussed in the last Sub-section. Complying in every respect with the European Standard for high fidelity sound reproduction, it

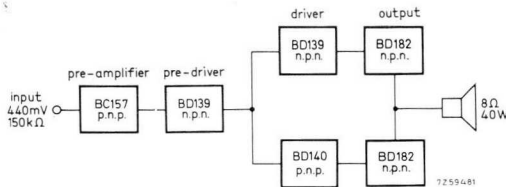

Fig. 3.49. Block diagram of the 40 watt hi-fi amplifier.

will deliver 40 W r.m.s. continuous sine-wave power into an 8 Ω load.

Silicon transistors have been used throughout the circuit and the output stage comprises two rugged BD182 power transistors in the usual quasi-complementary single-ended Class-B push-pull configuration. The complementary driver transistors, however, are now the BD139/BD140 types because of the higher supply voltage (60 V). An n-p-n BD139 is used for the Class-A pre-driver stage, whilst a p-n-p BC157

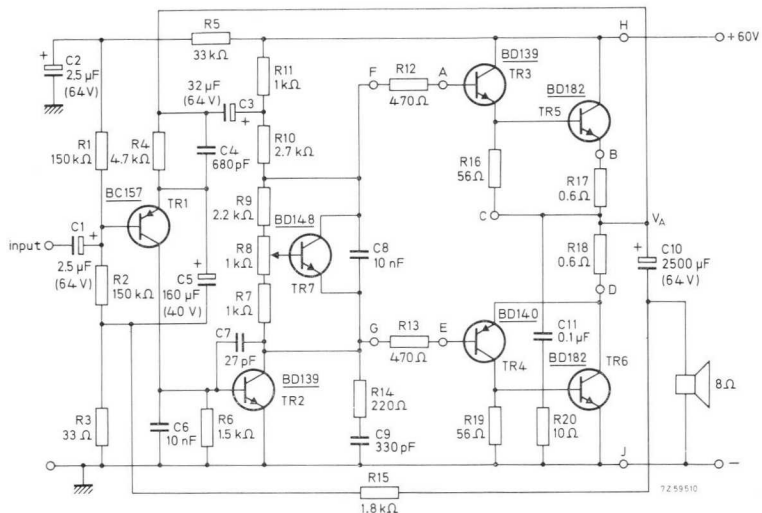

Fig. 3.50. Circuit diagram of 40 the watt hi-fi amplifier.

functions as the pre-amplifier and mid-point voltage stabilizer. The block diagram given in Fig. 3.49 shows the general arrangement.

The circuit diagram is given in Fig. 3.50. In view of the similarities between this amplifier and the 25 W amplifier no detailed description of its operation is necessary, but a few of the circuit parameters may be of particular interest. The operating current of the pre-amplifier stage in the final amplifier is 0.4 mA and feedback is applied around the circuit as before, a voltage feedback factor of 280 being used. The input impedance is again 150 k Ω .

The Class-A BD139 pre-driver stage operates with a collector current of 7.7 mA and no heat-sink is required.

Complementary driver transistors TR_3 and TR_4 again act as a phase inverter. Typical quiescent current is about 10 mA. In the worst case, represented by a 10% higher supply voltage, minimum gain transistors in the output stage, a 20% lower external load impedance and driven by a signal having an amplitude of $2/\pi$ times the peak sine-wave input, the dissipation of the driver transistors is 840 mW. Maximum current

which TR_3 has to deliver is 209 mA; TR_4 passes a somewhat lower current. TR_3 requires a heat-sink but it is recommended that the driver transistors are each mounted on separate 1 mm thick bright aluminium heat-sinks of $2 \times 2 \text{ cm}^2$.

The peak output current for $P_o = 40 \text{ W}$ into an 8Ω load is 3.2 A. The peak output voltage for 40 W is 25.5 V. Upper circuit losses are about 4.0 V, and lower circuit losses total 5.0 V. To guarantee 40 W output power with minimum devices the supply voltage must equal the sum of the total voltage losses and twice the peak output voltage excursion. This becomes:

$$4.0 \text{ V} + 5.0 \text{ V} + 2(25.5 \text{ V}) = 60 \text{ V}.$$

The mid-point voltage V_A is therefore 30 V.

To compensate the quiescent currents of the complementary driver and output transistors against ambient temperature and supply voltage variations, the circuit previously described for the 25 W amplifier has been used. TR_7 is an n-p-n transistor BC148. Each output transistor requires a 2 mm thick bright aluminium heat-sink measuring at least $8 \times 8 \text{ cm}^2$.

Short-circuit protection networks are required for this amplifier, as with the 25 W amplifier, for the same reasons. In Figs. 3.51 and 3.52 two protection networks are given. That shown in Fig. 3.51 consists of two parts; a regulated power supply unit and the other an additional transistor between the base of the driver transistor TR_4 and the mid-point of the amplifier. The circuit of Fig. 3.52 is similar to that of the 20 W amplifier and also Protection Circuit II of the 25 W amplifier. Where an unregulated power supply is used BD183 output transistors should be used instead of the BD182.

Firstly, consider Fig. 3.51(a). The regulated supply unit delivers a constant d.c. voltage up to a certain level of output current. When the current consumption exceeds this level, for example – due to a short-circuit in the speaker leads, the d.c. output voltage of the supply unit drops to almost zero. As soon as the short-circuit is removed the stabilized d.c. voltage commences to return to its previously set value, falling again to zero when the current drawn becomes too high. This repetitive behaviour is a function of the time-constant of the supply unit and the magnitude of the current consumption.

With this form of protection the current through the upper part of the output circuit (TR_5) and the driver transistor TR_3 is limited. But not so

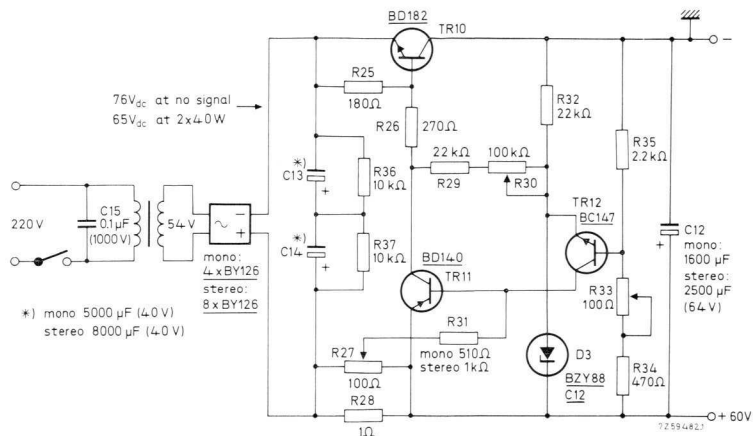

(a) regulated power supply unit

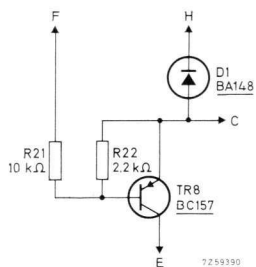

(b) part of Protection Circuit I

Fig. 3.51. Short-circuit protection network I.

for the lower stage of the amplifier due to the output coupling capacitor C_{10} acting as a "supply unit". Additional protection is therefore necessary for the lower part of the amplifier. This is obtained by connecting a p-n-p transistor BC157 between the base of the BD140 (TR_4) and the mid-point of the amplifier. The circuit is given in Fig. 3.51(b).

Under normal conditions the transistor is non-conducting. When the output current increases due to a short-circuit, the base potential of the p-n-p driver transistor TR_4 changes rapidly with respect to the d.c.

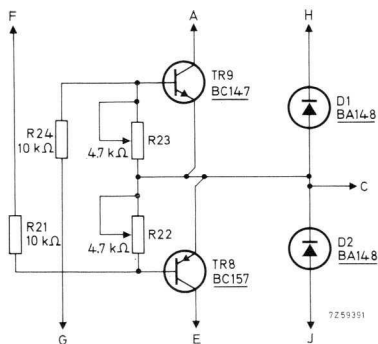

Fig. 3.52. Protection Circuit II.

mid-point voltage V_A . At a certain level the protection transistor TR_8 (Fig. 3.51(b)) conducts and the a.c. drive current flows through TR_8 instead.

When the output is not short-circuited, but when complex load and overdrive conditions apply, the output current also becomes higher than the maximum sine-wave excursion. The upper output stage is limited by the supply unit, but the protection transistor conducts and the output and complementary driver transistors become reverse-biased. To avoid damage to the upper transistors, a BA148 diode is reverse connected across them.

The supply unit of Fig. 3.51(a) can also be used for stereo applications. In such cases the current limiting value must be set *twice* as high. The bridge rectifier uses $4 \times$ BY126 rectifier diodes for mono; on stereo $8 \times$ BY126 diodes are required.

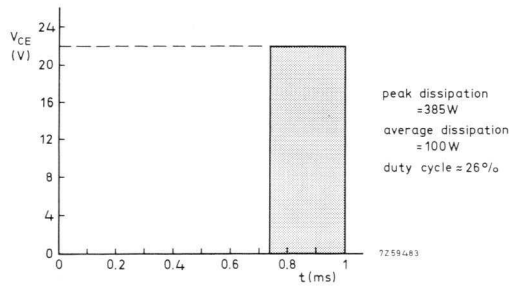
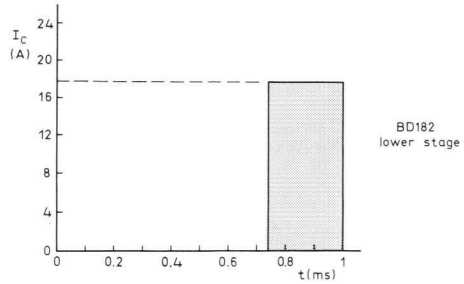
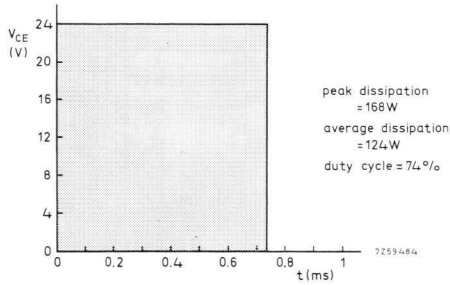
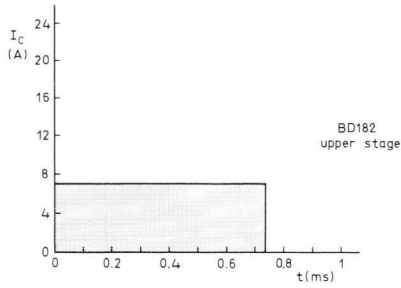
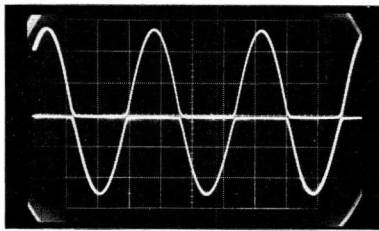
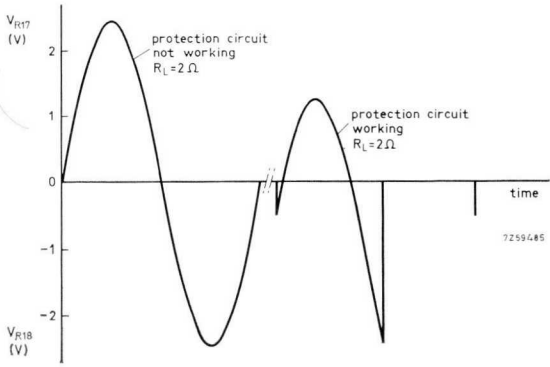

Fig. 3.53. Short-circuit conditions of the 40 W amplifier without protection.

A BD182 transistor (TR_{10}) is used as a current regulator. This acts as the current source with the load in the collector circuit. The current source is controlled by a BD140 p-n-p transistor TR_{11} , which determines the maximum available base drive current for the BD182. The supply current limiting value is set by the potentiometer R_{27} . The d.c. output voltage is controlled by a 12 V zener diode BZY88-C12 and a BC147 transistor, TR_{12} . The voltage divider network R_{33} - R_{34} - R_{35} is used to obtain exactly 60 V d.c. supply voltage, by adjustment of R_{33} .

Fig. 3.52 shows Protection Circuit II. It is identical with that used in the 20 W amplifier and also as an alternative in the 25 W amplifier. Whilst Fig. 3.53 shows the short-circuit conditions in the 40 W amplifier output stage without protection, reference to Fig. 3.54 shows what happens under short-circuit conditions when Protection Circuit II is used.



circuit not working

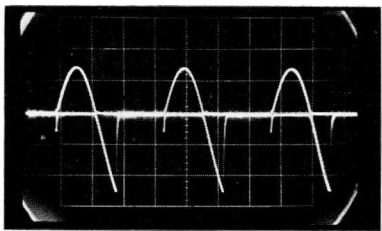

circuit working

Fig. 3.54 (a). Short-circuit conditions for Protection Circuit II with 2Ω load.

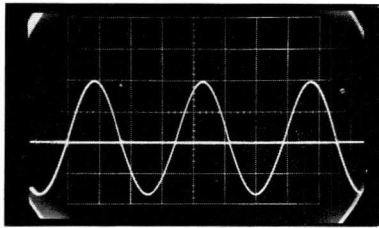
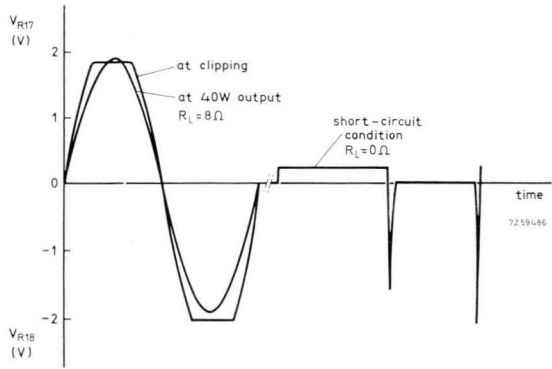

at 40 W output

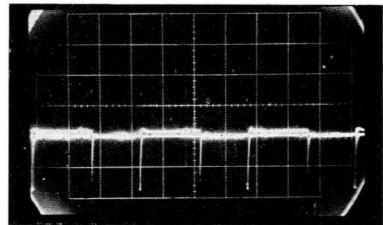

short-circuit conditions

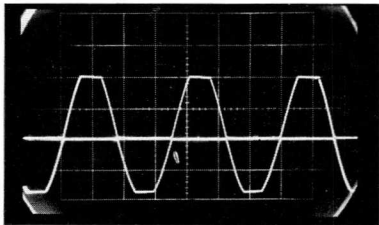

at clipping

Fig. 3.54 (b) Conditions in Protection Circuit II.

The output currents flowing through R_{17} and R_{18} (Fig. 3.50), are shown in Fig. 3.54, before and after the protection circuit is functioning. On the left of Fig. 3.54(a) the voltage drop across R_{17} and R_{18} is shown, without the protection circuit working, when a load impedance of $2\ \Omega$ is connected. Peak current under these conditions is 4.1 A. At an increased current, protection commences and the voltage across R_{17} and R_{18} falls as shown on the right of Fig. 3.54(a). The level at which protection starts working is adjusted by potentiometers R_{22} and R_{23} in Fig. 3.42. The $2\ \Omega$ load condition is shown here because this value must be used to adjust the protection circuit.

Fig. 3.54(b) shows what happens under actual conditions when an $8\ \Omega$ load impedance is connected. The left hand side of Fig. 3.54(b) shows the voltage drop across R_{17} and R_{18} for 40 W output and at clipping. The right hand side of Fig. 3.54(b) shows the effect of a short-circuit for the same a.c. input signal as for clipping. The average currents through the output transistors are now much reduced.

The short-circuit protection networks are adjusted as follows:

Protection Circuit I

- (a) Disconnect the amplifier from the regulated supply unit.
- (b) Connect a d.c. voltmeter across capacitors C_{13} - C_{14} (100 V range).
- (c) Adjust R_{30} for maximum resistance value.
- (d) Adjust R_{27} to the TR_{11} end of its track.
- (e) Switch on mains supply.
- (f) If a d.c. voltage appears across C_{13} - C_{14} , connect d.c. voltmeter across C_{12} .
- (g) If there is no voltage across C_{12} , turn R_{30} *slowly* until there is about 60 V. Do NOT return R_{30} , after this step.
- (h) Adjust R_{30} for *exactly* 60 V across C_{12} .
- (i) Switch off the power supply and connect the amplifier. Connect a $2\ \Omega$ resistor (40 W) across the output, or two $2\ \Omega$ resistors for a stereo installation.
- (j) Connect an oscilloscope across R_{18} .
- (k) Inject a 1000 Hz signal at the amplifier input of sufficient amplitude to produce 2.5 V peak across R_{18} (approximately 4.1 A peak current). The result is shown in Fig. 3.55(a).
- (l) Increase the input signal voltage further. The oscilloscope should now show a trace similar to Fig. 3.55(b) indicating that protection is taking place. Both stereo channels should indicate the same way.

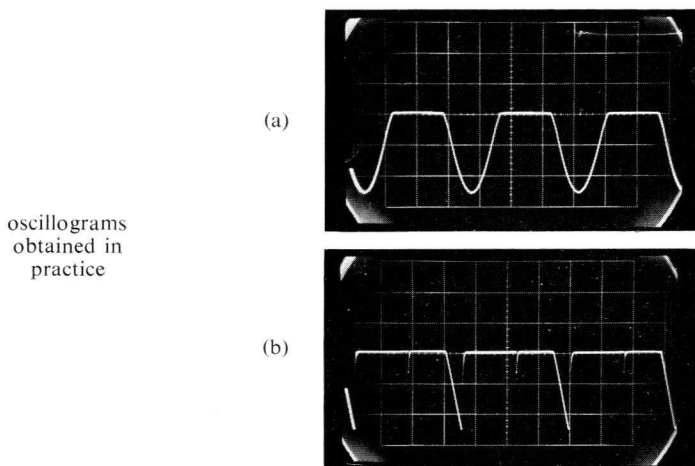
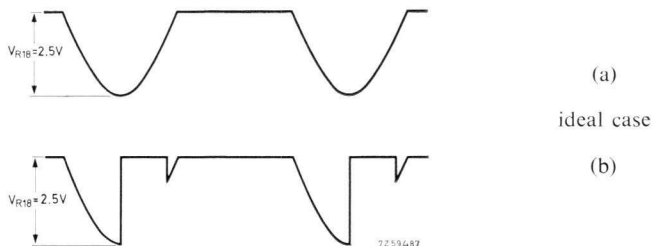

Fig. 3.55. Adjustment of short-circuit Protection Network I.

- (m) Reduce input to obtain the trace of Fig. 3.55(a).
- (n) Adjust with R_{27} the maximum current level just before the point at which the protection of the regulated power supply starts to work, i.e. before the trace of Fig. 3.55(a) falls away to become Fig. 3.55(b).
- (o) Check the supply unit again by shunting C_{12} with a $2\ \Omega$ resistor, the d.c. voltmeter still connected across C_{12} . If the supply voltage does not re-appear after removing the $2\ \Omega$ resistor, a very slight readjustment of R_{30} is necessary.

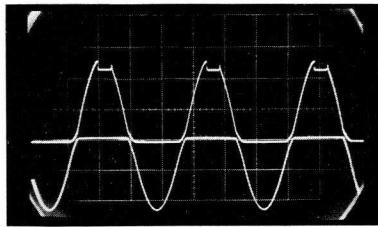
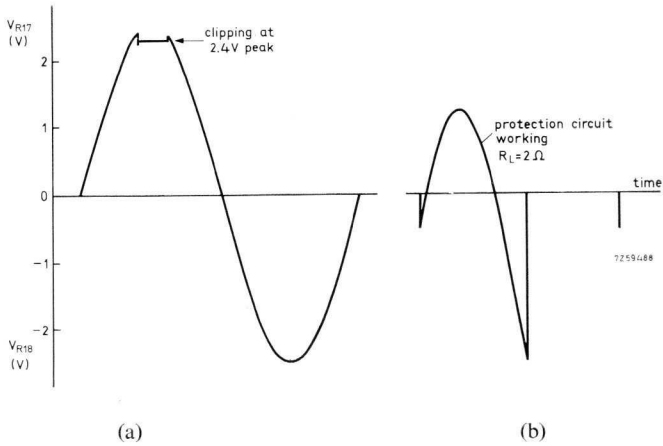

Fig. 3.56. Adjustment of Short-circuit Protection Network II.

Protection Circuit II

- Set potentiometers R_{22} and R_{23} to their mid-positions.
- Connect a 2Ω resistor (40 W) across the amplifier output.
- Connect an oscilloscope across resistor R_{17} . If this is a double-beam instrument, its other input can be connected across R_{18} .
- Inject a 1000 Hz input signal of sufficient amplitude to produce a 2.4 V peak signal across R_{17} .
- Adjust R_{23} for clipping of the waveform at 2.4 V as shown in Fig. 3.56(a).
- Adjust R_{22} for a trace similar to that shown in Fig. 3.56(b) of the voltage across R_{18} . This indicates that the protection circuit has just started working.

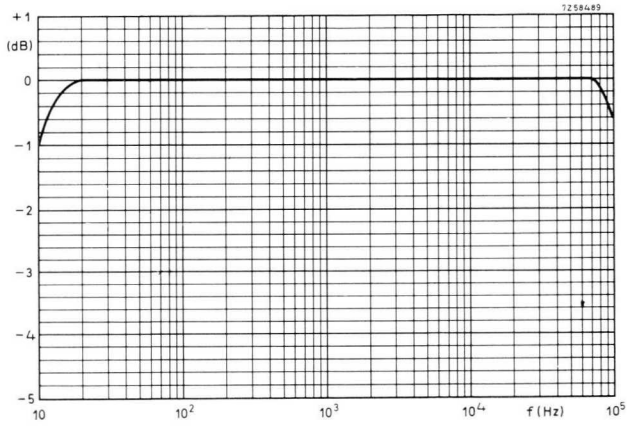

Fig. 3.57. Frequency response characteristic of 40 watt hi-fi amplifier. 0 dB = 6 dB below 40 W.

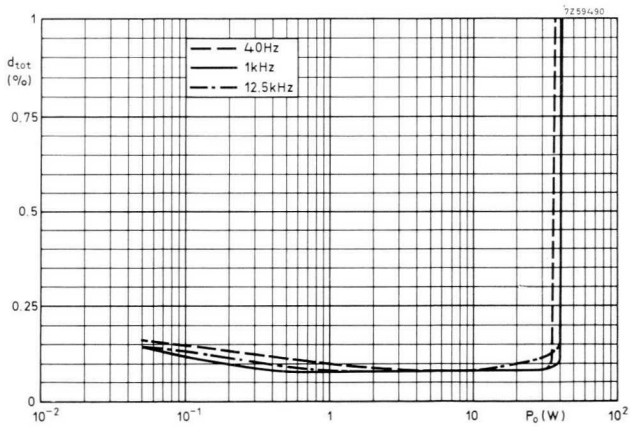

Fig. 3.58. Total harmonic distortion of 40 watt hi-fi amplifier.

The frequency characteristic shown in Fig. 3.57 is within 0.5 dB of the 1000 Hz response from below 15 Hz to 95000 Hz. Total harmonic distortion as a function of output power at the three frequencies 40 Hz, 1000 Hz and 12500 Hz is shown in Fig. 3.58. These curves are valid for amplifiers with or without protection networks incorporated, and the harmonic distortion does not exceed 0.2 % at 40 W. Intermodulation distortion is 0.8 % at maximum power output, measured with frequencies of 250 Hz and 8000 Hz in the ratio of 4:1.

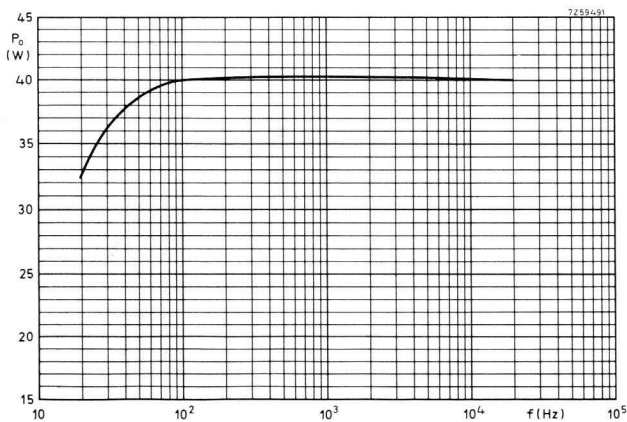

Fig. 3.59. Power bandwidth characteristic of 40 watt amplifier.

The power bandwidth characteristic is given in Fig. 3.59, for a total distortion of 1 %, using an 8Ω load and a source impedance of $1 \text{ k}\Omega$.

Fig. 3.60 illustrates the printed-wiring board for the 40 W amplifier. The component layout is shown in Fig. 3.61. Interconnections between this amplifier, the power supply unit and the Universal Pre-amplifier are *most important* and the recommendations of Section 3.4 must be closely followed otherwise instability is most likely to occur. The components for Protection Circuit II can be clearly identified in the photograph of the completed amplifier.

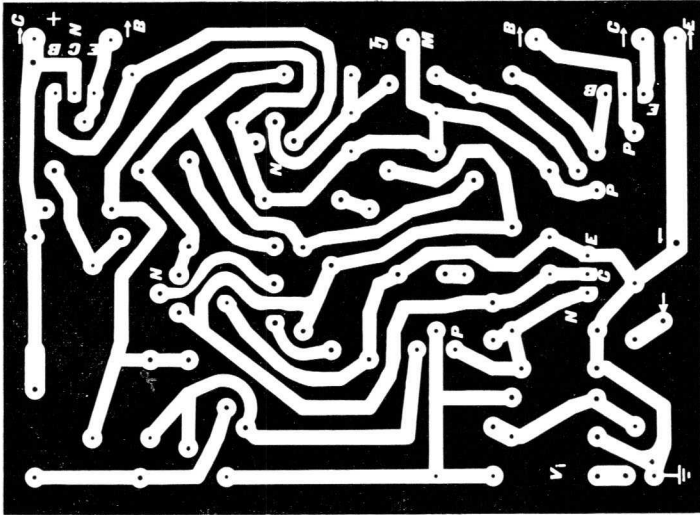

Fig. 3.60. Printed-wiring board for 40 watt amplifier.

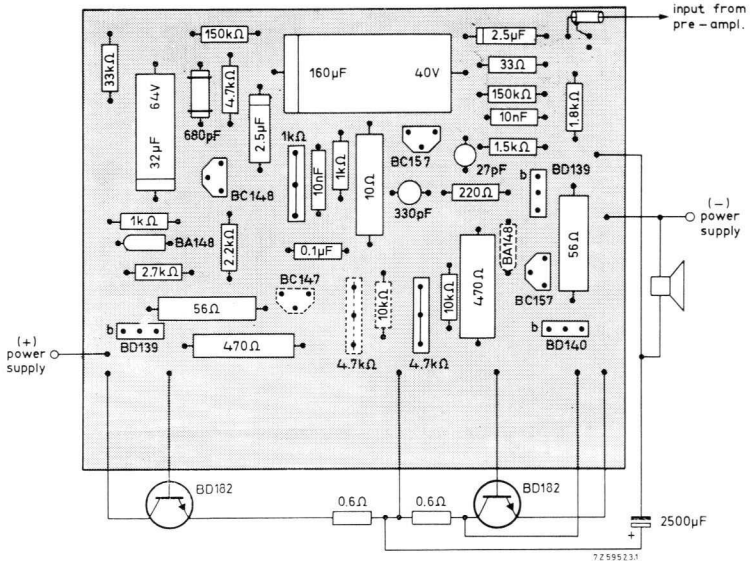

Fig. 3.61. Component layout of printed-wiring board for 40 watt amplifier employing Protection Circuit I. Dotted components are added if Protection Circuit II is used.

3.6.6 CIRCUIT 26 – OVERDRIVE INDICATOR FOR 25 W AND 40 W AMPLIFIERS

Fig. 3.62 shows the circuit of a simple overdrive indicator which may be used with the 25 W and 40 W high fidelity power amplifiers. It is intended for use in stereo applications and causes a lamp to light at the onset of clipping, indicating that audible distortion is about to occur.

The inputs to the circuit are taken from the output terminals of each

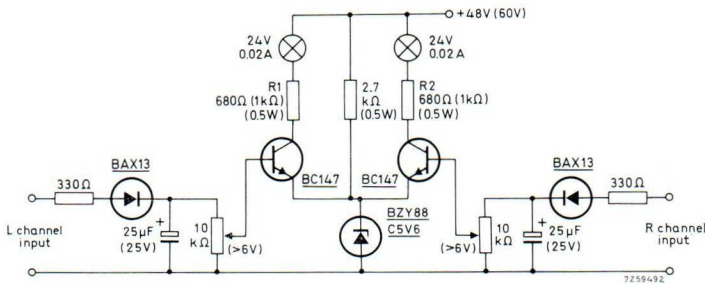
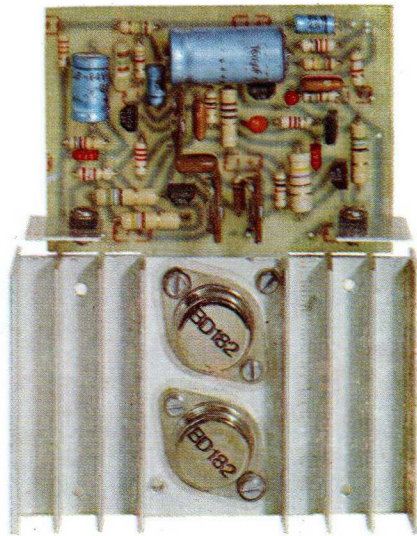

Fig. 3.62. Circuit of overdrive indicator for 25 W and 40 W amplifiers.

channel amplifier. The audio signals are rectified by the BAX13 diodes and a d.c. voltage is developed across each potentiometer. The BC147 transistors are normally held cut off by the BZY88-C5V6 zener diode, but when the voltage on the base of the BC147's exceeds 6 V the transistors are switched on and the lamps light.

For setting-up, an oscilloscope is connected across each pair of input terminals and with a music input signal the potentiometers are adjusted for the lamps to light at the onset of clipping. The values of R_1 and R_2 , and also the supply voltage, shown in brackets, apply when the circuit is used on a 40 + 40 W stereo equipment. No other components are affected.



The 40 W high fidelity power amplifier. Components for Protection Circuit II have been incorporated in this model.

4. Integrated Circuit Amplifiers

4.1 Application of Integrated Circuits to Audio Amplifiers

Integrated circuits in the audio field offer a number of special advantages. Not only where small size is the main consideration but also on grounds of cost, the use of an integrated circuit is a particularly attractive alternative to discrete components.

The main advantage of employing integrated circuits lies in the use of *less* discrete components which require individual storage, handling and mounting. Also the overall circuit reliability will be higher, since there are *less soldered connections* to be made in the final product.

The reduced dimensions of an integrated circuit make it of special appeal for microphone applications. With capacitor microphones, for example, the pre-amplifier may be mounted in the body of the microphone close to the sensitive element. Another clear example is that of a hearing aid amplifier which, by employing an integrated circuit, can be completely inserted in the ear.

To illustrate the application of integrated circuits in the audio field, four different types have been selected and practical circuits are given showing examples of their use. The TAA300 has a 1 W Class-B output stage and needs only 10 mV drive for full output; the TAA 320 is specially designed for high impedance applications such as crystal pick-ups; the TAA435 is a pre-amplifier and driver stage intended primarily for car radios and the TAA310 is a low-noise pre-amplifier for tape recorders. The TAA300 has been described in greater detail than the other integrated circuits for the benefit of interested readers.

4.2 Practical Circuits

4.2.1 CIRCUIT 27 – ONE WATT TRANSFORMERLESS CLASS-B AUDIO AMPLIFIER FOR RECORD PLAYERS USING THE TAA300 INTEGRATED CIRCUIT

Performance specification, each channel:

nominal power output	1 W into 8 Ω load
sensitivity (1 000 Hz) for $P_o = 1$ W	1.5 V
pick-up (1 000 pF)	8.5 mV (typ.)
at TAA300 input	> 10 k Ω (typ. 15 k Ω)
input impedance of TAA300	120 to 26 000 Hz
frequency response (-3 dB)	10 %
total harmonic distortion at $P_o = 1$ W	≈ 1 %
at onset of clipping $P_o \approx 0.8$ W	73 dB
unweighted signal/noise ratio (ref. $P_o = 1$ W)	10
voltage feedback factor	9 V
nominal supply voltage	180 mA (typ.)
current consumption at $P_o = 1$ W	

In many portable audio applications the required output power does not exceed 1 W. The sensitivity and the input impedance in this case should

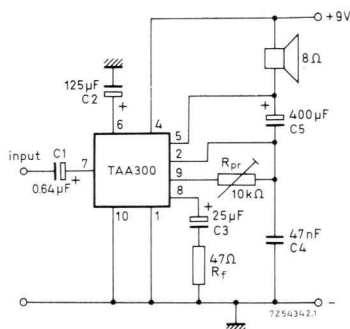

Fig. 4.1. Basic circuit arrangement of one watt amplifier.

be such that the maximum output power is obtained when the input is connected to a ceramic pick-up element or a detector in a portable radio. Other requirements are that the circuit should still operate at half the nominal supply voltage and that the total current drain is low. Furthermore the complete audio circuit should be compact, easy to mount, have a low noise and a reasonably low distortion factor.

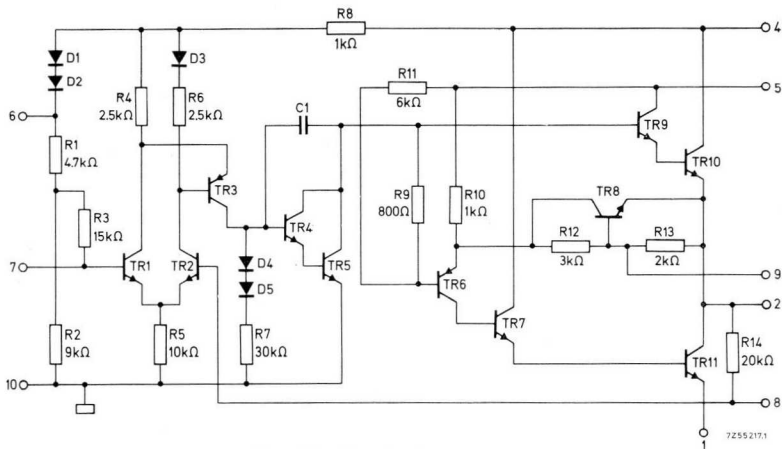

Fig. 4.2. Circuit of the TAA300.

To meet these requirements the TAA300 has been specially developed. It contains a silicon chip of only 2 mm^2 , on which 9 planar n-p-n transistors, 2 p-n-p transistors, 5 diodes, 14 resistors and 1 capacitor are integrated. The TAA300 only requires a few external components as shown in the basic circuit of Fig. 4.1 which will be used for purposes of discussion.

The circuit diagram of the TAA300 is shown in Fig. 4.2. The TAA300 consists of an input stage (TR_1 and TR_2), a driver stage (TR_3 to TR_5) and an output stage (TR_6 to TR_{11}).

The input stage is a differential amplifier. Since resistor R_5 in the common emitters of the differential stage is very large with respect to the differential resistance of the transistors, it can be regarded as a constant current source.

The voltage at the base of TR_1 is obtained by means of a low resistance voltage divider across the supply. Resistor R_3 between the voltage divider and the base of TR_1 increases the input impedance to about $15 \text{ k}\Omega$. Two diodes are connected in series with R_1 so that the voltage at the base of TR_1 does not vary directly with the supply voltage. This allows the circuit to be used at supply voltages of 4.5 to 10 V. The point below the two diodes in the bias network of the first transistor is connected to pin 6, thus enabling the supply line to be decoupled by means of an external capacitor. The layout of resistors R_1 , R_2 and R_8 is such that the spread of the base voltage of TR_1 remains below 5 %.

The driver stage consists of 2 n-p-n transistors TR_4 and TR_5 in cascade. The d.c. coupling between the differential input stage and the driver stage is by means of a p-n-p transistor (TR_3). This transistor has the function of the level shifter, but it also presents a symmetrical load to the differential input stage. Consequently the noise factor of the input stage is no worse than that of a single transistor, whereas the advantages of a differential input stage are maintained.

The voltage gain of the driver stage is rather high and therefore this stage is used to cut off the frequencies above the audio spectrum by means of a small integrated capacitor C_1 inserted between the base of TR_4 and its collector. The voltage gain of the cascade driver stage will be about 200 when the quiescent current of the stage is 0.47 mA. This gain figure, in combination with a collector/base capacitance C_1 of 10 pF, makes the capacitance between the base of TR_4 and earth about $200 \times 10 = 2000$ pF.

Without feedback the upper frequency is limited to approximately 3 kHz (-3 dB). The total frequency response can be expanded to about 30 kHz (-3 dB) by using large overall feedback. To reduce the spread of the input impedance of this stage, and thus the spread in cut-off frequency, a resistor of 30 k Ω is shunted across the input of the driver stage. D_4 and D_5 are connected in series with the resistor to decrease the current of the p-n-p level shift transistor (TR_3) and to stabilize the collector current of TR_4 and TR_5 against temperature variations.

In the TAA300, the conventional complementary pair principle is used. This gives a very simple and stable direct-coupled single-ended push-pull output stage.

To reduce the collector d.c. current of the driver transistor the output transistors must have large current gains, therefore two transistors in cascade are used. The output stage is made complementary by placing p-n-p transistor TR_6 in front of the lower cascade. Symmetrical drive of the output transistors is ensured by making the current gain of the p-n-p transistor unity.

The output voltage is limited only by the knee voltage of output transistors TR_{10} and TR_{11} and, for symmetrical clipping of the output signal, a mid-point voltage of half the supply voltage is required. Fig. 4.3 shows the mid-point voltage as a function of the supply voltage. The quiescent current of the output stage could be stabilized against the influence of battery and temperature variations of the V_{BE} 's of TR_9 , TR_{10} and TR_6 by using three diodes. In the TAA300 these diodes are

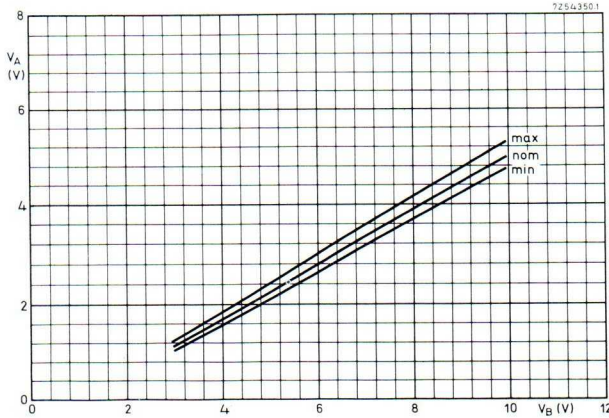

Fig. 4.3. Variation of mid-point voltage V_A with supply voltage V_B .

replaced by transistor TR_8 and resistors R_{12} and R_{13} . Since the integrated components may spread, it should be possible to adjust the quiescent current of the output transistors, for which purpose the base and emitter of TR_8 have external connections.

For a supply voltage of 9 V, the total quiescent current consumption must be preset at 8 mA. The typical current consumption of all stages (except for the output stage) is then about 3.5 mA as shown:

– bias network of the input stage	500 μA
– total current of differential input stage	380 μA
– driver stage	470 μA
– typical collector current of stabilization transistor TR_8	2100 μA
– collector current of TR_7 and TR_9	100 μA
	<hr/>
	3550 μA

The typical quiescent current of the output stage is therefore $8 - 3.5 = 4.5$ mA which is necessary to minimize the cross-over distortion.

Fig. 4.4 shows the spread of the total quiescent current consumption of the TAA300 versus supply voltage when preset at 8 mA for a supply voltage of 9 V. The dotted line shows the typical quiescent current consumption without the quiescent current of the output stage.

The maximum dissipation for sine-wave drive of a Class-B amplifier is theoretically obtained when the peak collector current of the output

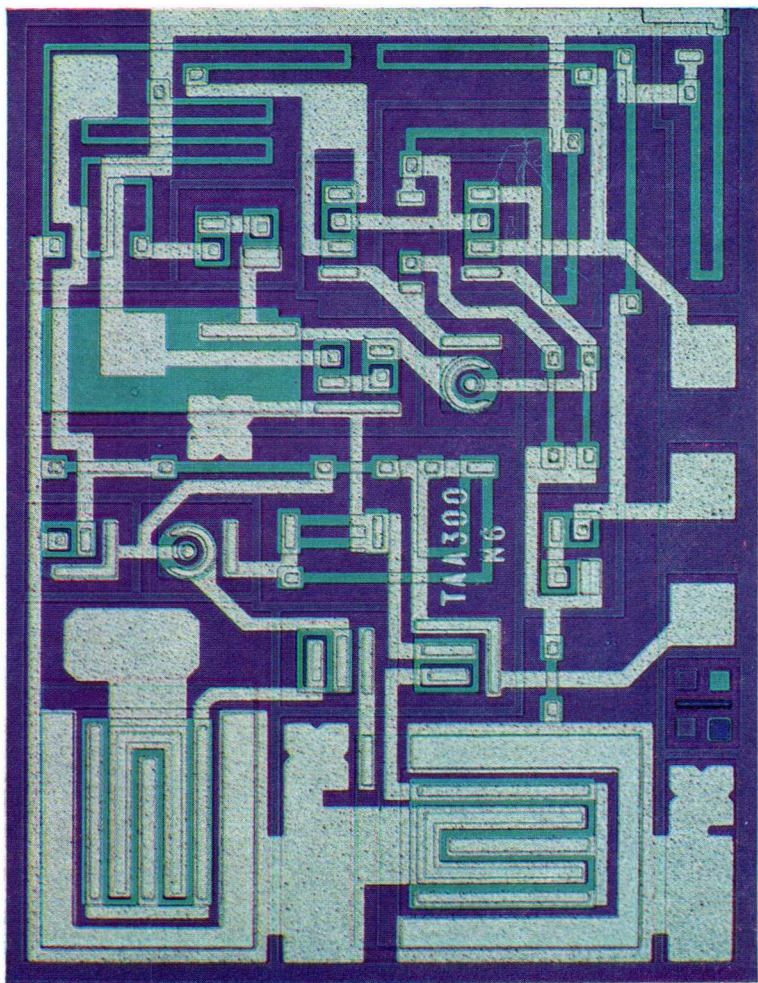

The TAA300 integrated circuit enlarged 80 times. It combines 11 transistors, 5 diodes, 14 resistors and 1 capacitor on a single chip of 2 mm².

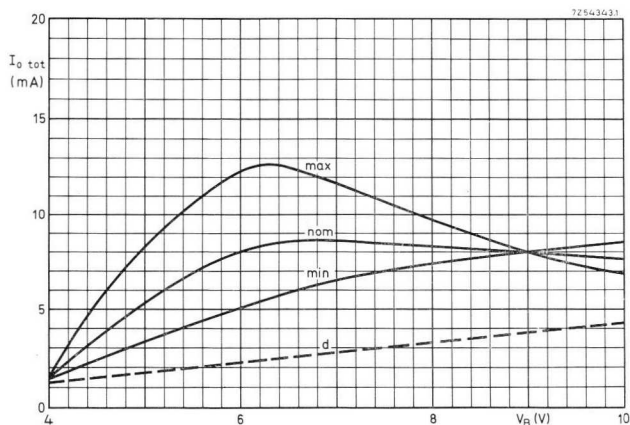

Fig. 4.4. Spread in total quiescent current $I_{o \text{ tot}}$ with supply voltage V_B .

transistors is $2 I_{CM}/\pi$. For a 9 V circuit with a load impedance of 8Ω the theoretical maximum peak current is:

$$I_{CM} = \frac{V_B}{2 R_L} = 560 \text{ mA.}$$

At a current of $2 I_{CM}/\pi$ the power from the supply is:

$$\frac{V_B \times 2/\pi I_{CM}}{\pi} = \frac{9 \times 360 \times 10^{-3}}{\pi} = 1020 \text{ mW.}$$

The output power fed into the load impedance is:

$$\left(\frac{2 I_{CM}/\pi}{\sqrt{2}} \right)^2 \cdot R_L = 520 \text{ mW.}$$

Consequently the dissipation in the output transistors amounts to $(1020 - 520) \text{ mW} = 500 \text{ mW}$. Together with the current of about 10 mA for all pre-stages, the total dissipation will be increased by approximately 90 mW. Thus the total dissipation becomes approximately 600 mW at a supply voltage of 9 V.

For sine-wave drive the current drain is 180 mA at $P_o = 1 \text{ W}$, so at a supply voltage of 9 V the total dissipation of the TAA300 will be $(9 \times 0.18) - 1 = 0.62 \text{ W}$. Fig. 4.5 shows the dissipation as a function of output power.

The maximum dissipation for music and speech is always lower than for sine-wave drive. Therefore, when this amplifier is used as a normal audio amplifier it is permissible to assume a maximum dissipation of 500 mW at a battery voltage of 9 V.

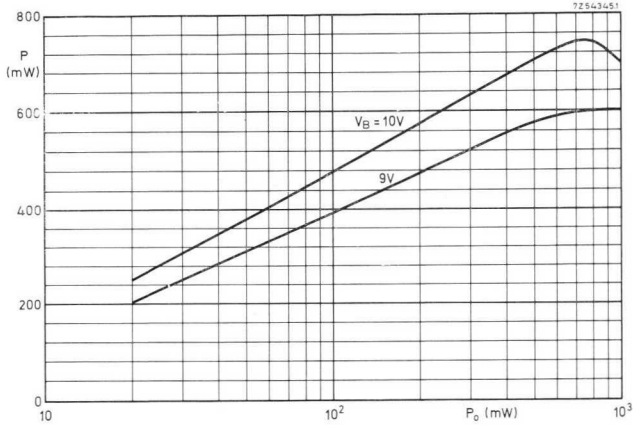

Fig. 4.5. Total dissipation of the TAA300 for different output powers.

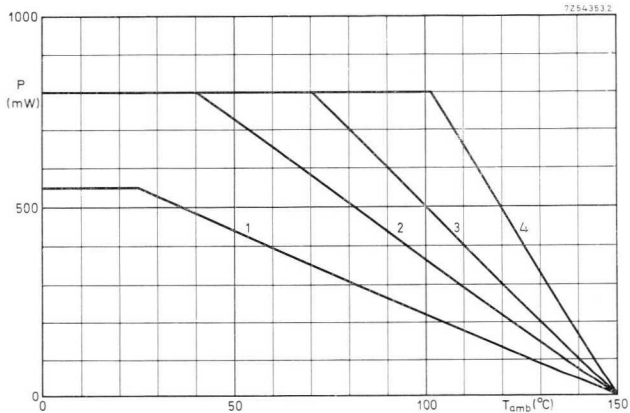

Fig. 4.6. Maximum permissible dissipation over a range of ambient temperatures for various cooling systems:

Curve 1: without cooling;

Curve 2: with cooling clip No. 56265;

Curve 3: with cooling clip No. 56265 and a heat-sink of 20 cm²;

Curve 4: with an "infinite" heat-sink.

The thermal resistance of the TAA300 without heat-sink is $225\text{ }^{\circ}\text{C}/\text{W}$. Due to the good thermal coupling between the output transistors and the stabilizing components, use can be made of the high junction temperature permitted in silicon transistors. With a maximum dissipation of 500 mW and the maximum crystal temperature of $150\text{ }^{\circ}\text{C}$, the 1 W amplifier can be used without heat-sink up to an ambient temperature of $150 - (0.5 \times 225) = 37.5\text{ }^{\circ}\text{C}$.

Taking into account a maximum voltage of 10 V and continuous sine-wave drive, the maximum dissipation is 750 mW . For this condition

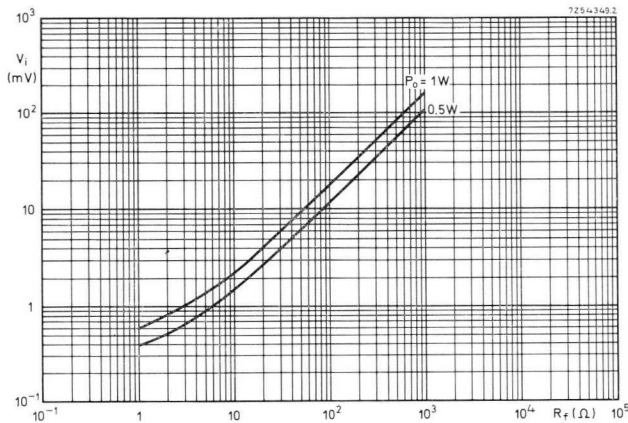

Fig. 4.7. Input voltage required as a function of the value of feedback resistor for power outputs of 0.5 W and 1 W .

the thermal resistance can be improved by means of a cooling clip. Fig. 4.6 gives the derating factor of the TAA300.

To reduce the distortion and to improve the frequency response and the input impedance, voltage feedback is applied. This is obtained by means of integrated resistor R_{14} , and the external components R_f and C_3 shown in the circuit diagram of Fig. 4.1. With a feedback resistor of $R_f = 47\text{ }\Omega$ the negative feedback is about 20 dB . This, together with the high open loop gain, gives a sensitivity of about 8.5 mV for an r.m.s. output voltage of 2.8 V . With a load impedance of $8\text{ }\Omega$ the output power will then be 1 W .

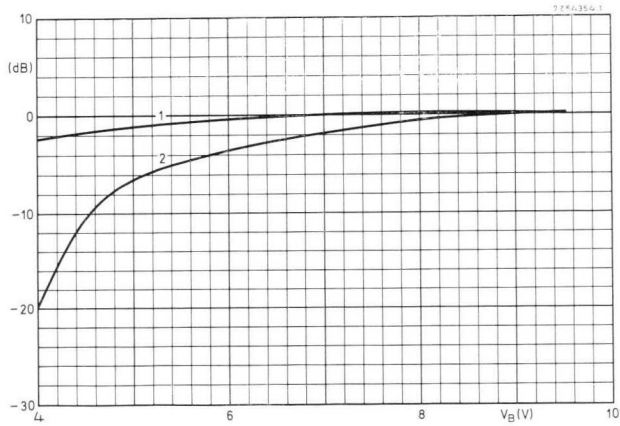

Fig. 4.8. Relative voltage gain for variation in supply voltage. 0 dB corresponds to 0.5 W. Curve 1: with feedback; Curve 2: without.

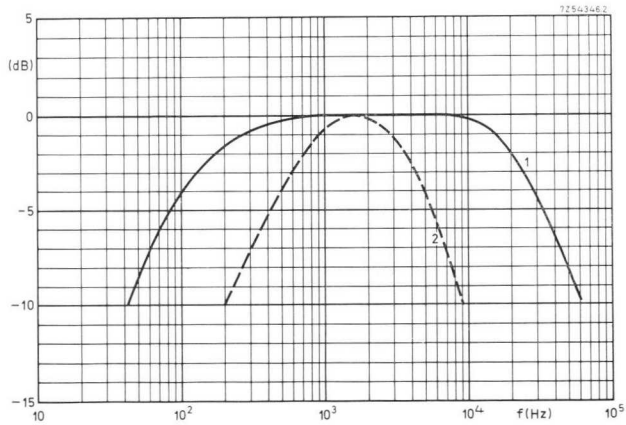

Fig. 4.9. Frequency response characteristic with and without the 47 Ω feedback resistor R_f in Fig. 4.1. 0 dB corresponds to 0.5 W. Curve 1: with feedback; Curve 2: without.

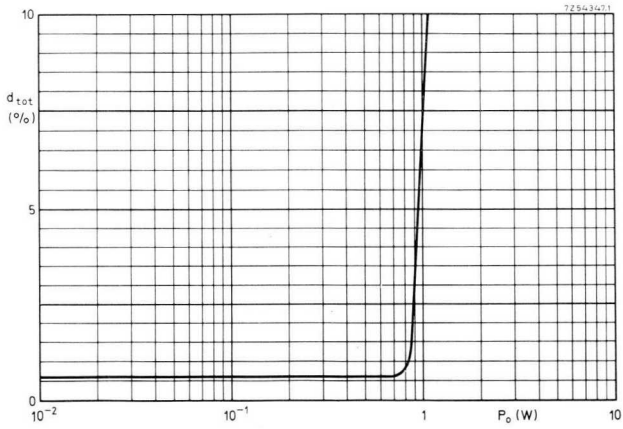

Fig. 4.10. Total harmonic distortion as a function of output power.

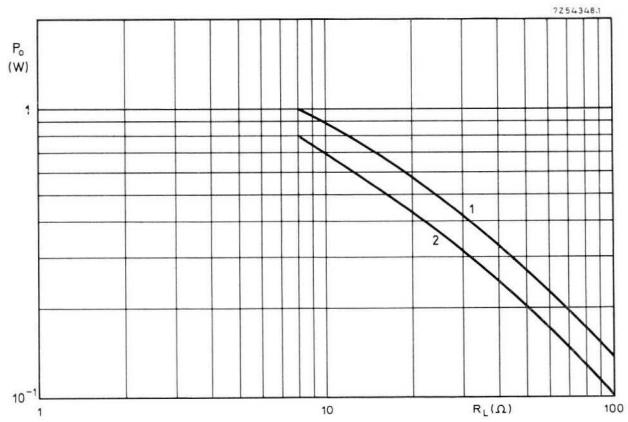

Fig. 4.11. Output power as a function of loudspeaker impedance. Curve 1: at $d_{tot} = 10\%$. Curve 2: just below clipping.

Fig. 4.7 gives the typical sensitivity for $P_o = 1$ W, and $P_o = 0.5$ W as a function of the feedback resistance R_f . Due to the rather high feedback, the spread is very small. The high feedback also makes the gain independent of the supply voltage as shown in Fig. 4.8.

Fig. 4.9 shows the frequency response without feedback and also

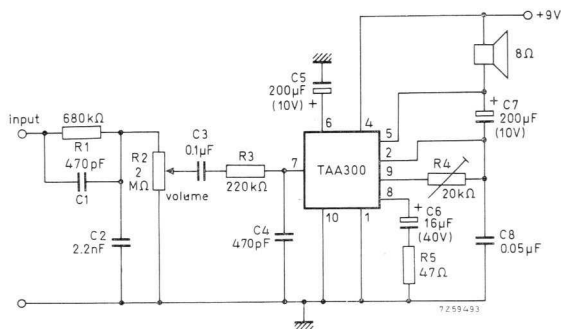

Fig. 4.12. Circuit diagram of one watt amplifier for use with a ceramic pick-up.

with a 47Ω feedback resistor R_f . The cut-off frequency (-3 dB) at the high frequency side is determined mainly by the integrated 10 pF capacitor between the collector and the base of the driver transistor TR_4 , together with the applied feedback. The -3 dB point for the lower frequencies is determined by the external capacitors. In Fig. 4.10 total harmonic distortion is given as a function of the output power, measured in the circuit of Fig. 4.1. The distortion level at an output power of 0.5 W is less than 1% . Cross-over distortion is very small and, due to the stabilization of the quiescent current, it remains small even when the supply voltage shifts from 5 to 10 V.

Typical noise input voltage is about $2 \mu\text{V}$, measured over a bandwidth from 30 Hz to 15 kHz with a source impedance of 2 k Ω . Related to an input signal of 8.5 mV, this means that the signal-to-noise ratio is 73 dB. With the input short-circuited, the r.m.s. noise output voltage is $280 \mu\text{V}$, which represents a noise power 80 dB below the maximum output power of 1 W.

The preferred output power can be obtained by choosing the appropriate speaker load. However, a speaker load below 8Ω is not permissible because the peak collector current of the output transistor would be too high. Fig. 4.11 gives the output power as a function of loudspeaker impedance. Curve I is measured at $d_{tot} = 10\%$ and Curve II is measured just before clipping.

Fig. 4.12 shows the practical circuit for use with a ceramic pick-up. The sensitivity for a source capacity of 1000 pF is 1.5 V for 1 W output and the half-power frequency response is 80 Hz to 26000 Hz . The $0.05 \mu\text{F}$ capacitor must be directly connected across pins 1 and 2 and a ceramic type should be used. Similarly, the 470 pF capacitor should be directly connected across pins 7 and 10. Equalization according to the R.I.A.A. characteristic is provided.

When using a practical low-cost power supply with a π -filter (5Ω decoupling resistor) and an overall impedance of 16Ω , the rms output is 600 mW for 10% distortion ($< 1\%$ up to 500 mW). Under these conditions no heat-sink would be necessary for an ambient temperature up to 50° C .

A printed-wiring board for stereo models is shown in Fig. 4.13. Separate volume controls for each channel are intended to be used with this particular layout.



Fig. 4.13. Printed-wiring board for stereo version of one watt amplifier.

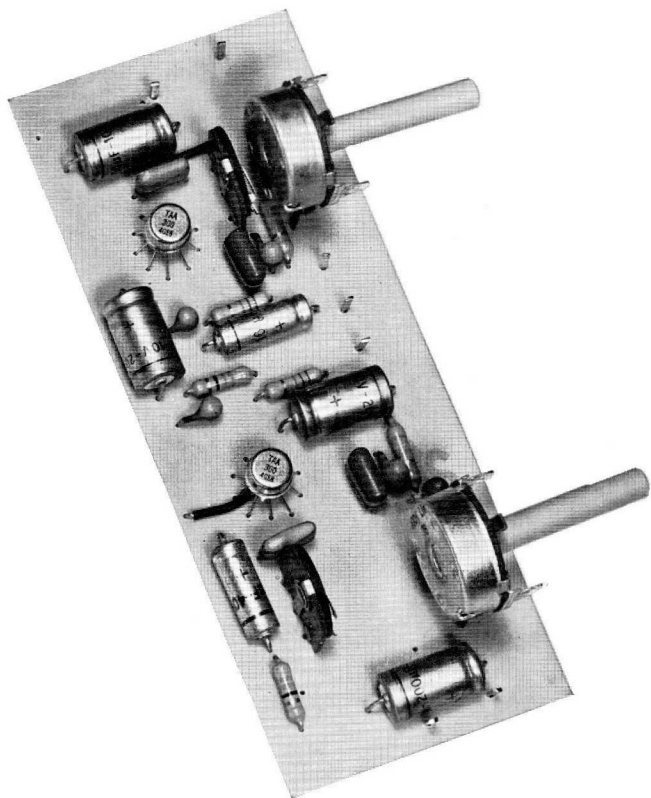

Stereo model of the one watt amplifier. The TAA300 integrated circuits can be clearly seen in the photograph.

4.2.2 CIRCUIT 28 – TWO WATT PICK-UP AMPLIFIER USING THE TAA320 AND THE HIGH VOLTAGE CLASS-A TRANSISTOR BD115

Performance specification

nominal power output	2 W into 4 Ω load
sensitivity (1000 Hz) for $P_o = 2$ W (for minimum devices)	140 mV
frequency response (-3 dB)	40 to 12000 Hz
total harmonic distortion at $P_o = 2$ W	3.5 %
voltage feedback factor	6.3 (typ.)
nominal supply voltage	100 V
current consumption	60 mA (total)

By using a TAA320 integrated circuit as pre-amplifier in combination with a BD115 high-voltage silicon power transistor, it is possible to

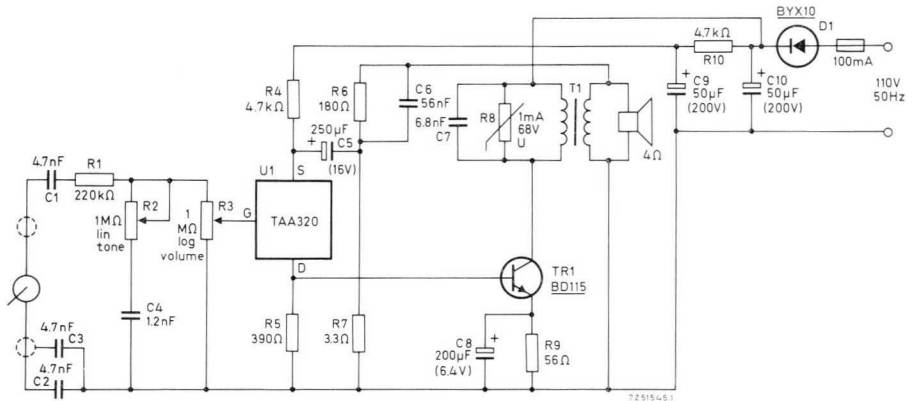

Fig. 4.14. Circuit diagram of two watt pick-up amplifier.

design a simple 2 W mains-fed Class-A amplifier which has an input impedance suitable for a crystal pick-up and a very high signal-to-noise ratio. If, by accident, the pick-up is dropped on the record a high peak voltage is generated. However, the TAA320 has been designed to withstand up to 100 V peak input without damage. In record players the mains transformer can even be dispensed with if a tapping on the motor is used. The circuit diagram is shown in Fig. 4.14.

The TAA320 is monolithic integrated circuit comprising three components mounted in a TO-18 envelope: a MOS transistor of the p-channel

enhancement type, an n-p-n silicon transistor and a resistor. Its circuit is given in Fig. 4.15.

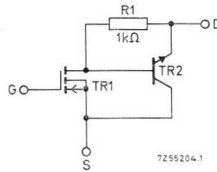

Fig. 4.15. Circuit of the TAA320.

The biasing resistor R adjusts the operating current I_S of the MOS transistor. Since its transconductance is proportional to $\sqrt{I_S}$, resistor R must be as small as possible to obtain maximum gain; on the other hand a low value reduces amplification of the silicon transistor. A value of about $1\text{ k}\Omega$ gives optimum overall transconductance of the whole integrated circuit.

The TAA320 has advantages in that it combines a high transconductance (g_{je}) with a high input impedance and a low noise level.

The BD115 high voltage silicon transistor is intended for Class-A output stages in audio amplifiers delivering an output of 2 W at a supply voltage of 100 V . The V_{CEK} of a lower-limit transistor BD115 is 245 V . The TAA320 requires an operating current of 10 mA to ensure a sufficiently high transconductance and low output conductance. Since a high supply voltage is available it is possible to make the TAA320 self-biasing. Despite the spread in V_{GS} , the operating current will remain fairly constant.

The maximum collector-to-emitter swing of the output stage is given by:

$$v_{ce} = V_B - V_{CEK} - I_C (R_E + R_{TR}).$$

in which:

V_B = supply voltage (100 V)

V_{CEK} = knee voltage of the BD115 at maximum peak current (6.5 V)

I_C = d.c. operating current of the BD115 (approx. 50 mA)

R_E = minimum required emitter resistance for thermal stability (from measurements it follows: $R_E = 56\ \Omega$)

R_{TR} = d.c. resistance of the output transformer primary (practical value approx. $140\ \Omega$).

Hence, \hat{v}_{ce} will be approximately 85 V .

The a.c. collector load is given by:

$$R_L = \frac{(\hat{v}_{ce})^2}{2 P_O}$$

For $P_O = 2 \text{ W}$ and $R_L = 1.8 \text{ k}\Omega$, the collector peak current (\hat{i}_c) is 47 mA. To avoid distortion owing to the current setting, a d.c. operating current of 50 mA is required. With $h_{FE} = 20$ for a lower limit transistor BD115, $I_{B_{\max}} = 2.5 \text{ mA}$. The d.c. base voltage to the common line (V_{R5}) is 3.5 V at an operating current of the BD115 of 50 mA and at $V_{BE} = 0.7 \text{ V}$.

To calculate the heat-sink required for the BD115, allowance must be made for an absolute maximum dissipation (P_{tot}) of about 6 W and a maximum ambient temperature of 50 °C. As the maximum permissible junction temperature is 200 °C, the total thermal resistance must be:

$$R_{th\ j-a} = \frac{T_j - T_{amb}}{P_O} = \frac{200 - 50}{6} = 25 \text{ }^\circ\text{C/W}.$$

The thermal resistance $R_{th\ j-mb}$ of the BD115 is 12.5 °C/W, so the thermal resistance from mounting base to ambient must be $25 - 12.5 = 12.5 \text{ }^\circ\text{C/W}$. This can be obtained by two methods:

- (a) with the transistor mounted directly on a horizontally positioned blackened aluminium heat-sink of 30 cm² ($R_{th} = 12.5 \text{ }^\circ\text{C/W}$);
- (b) with the transistor mounted via a mica washer on a blackened aluminium heat-sink of 50 cm² ($R_{th} = 9 \text{ }^\circ\text{C/W}$). The mica washer adds a thermal resistance of about 3.5 °C/W.

In the circuit diagram of the 2 W amplifier in Fig. 4.14, a tone control (R_1 , R_2 and C_4) has been included. The upper limit of the bandwidth (−3 dB) can be varied between 1 and 12 kHz by means of R_2 . The supply is obtained from the midtap of a 220 V a.c. turnable motor and the pick-up element is connected via two 4.7 nF capacitors because otherwise the common supply line might become connected to the live terminal of the mains.

The sensitivity for minimum devices is 140 mV for full output.

In Fig. 4.16 the distortion is plotted as a function of output power, measured at the primary of the output transformer. The spread in distortion for minimum and maximum devices is negligible for output powers below 1.5 W.

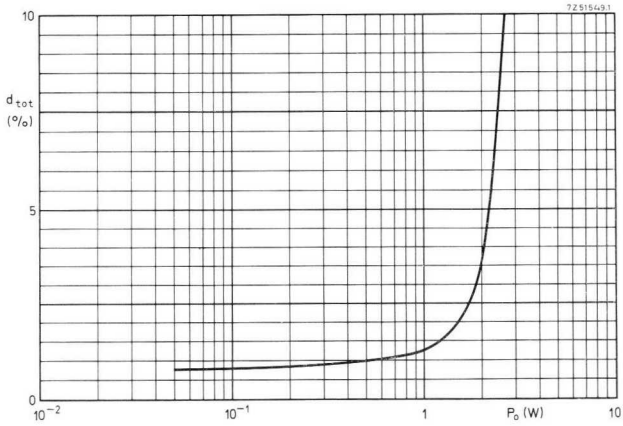

Fig. 4.16. Total distortion of the two watt amplifier as a function of output power at 1000 Hz.

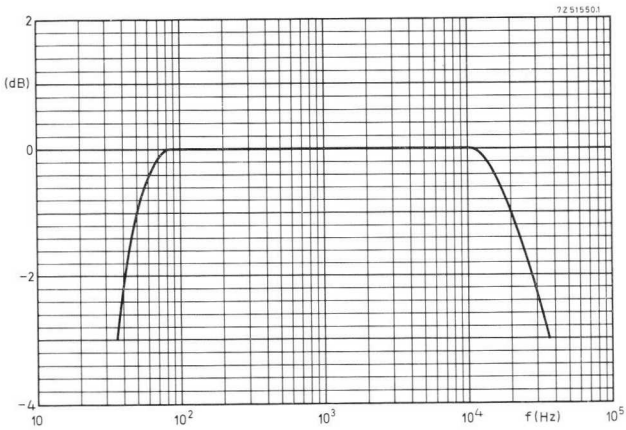

Fig. 4.17. Frequency response characteristic of the two watt amplifier. 0 dB = 2 W.

The frequency response of the amplifier is shown in Fig. 4.17, the -3 dB point at lower frequencies being determined by the output transformer.

Fig. 4.18 shows the power bandwidth for $d_{tot} = 5\%$.

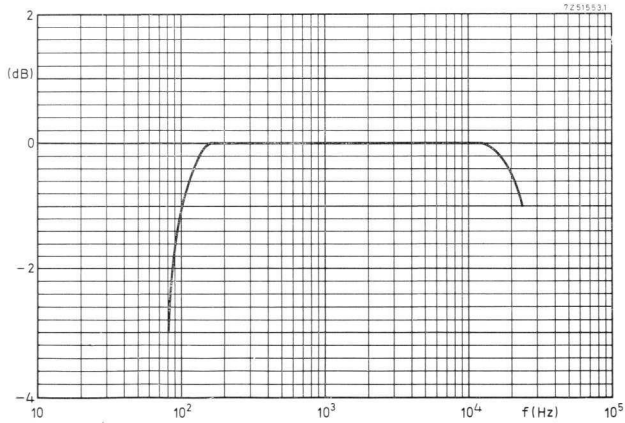

Fig. 4.18. Power bandwidth of the two watt amplifier at 5% distortion. 0 dB = 2.2 W.

4.2.3 CIRCUIT 29 – FOUR WATT PICK-UP AMPLIFIER USING THE TAA320 AND TWO BD115 OUTPUT TRANSISTORS

Performance specification:

nominal power output	4 W into 800 Ω load
sensitivity (1000 Hz) for $P_o = 4$ W (for minimum devices)	100 mV
frequency response (-3 dB)	50 to 12000 Hz
total harmonic distortion at $P_o = 4$ W	5.5 %
voltage feedback factor	4 (typ.)
nominal supply voltage	200 V
current consumption	72 mA (total)

Fig. 4.19 gives the circuit for a 4 W amplifier, using the integrated

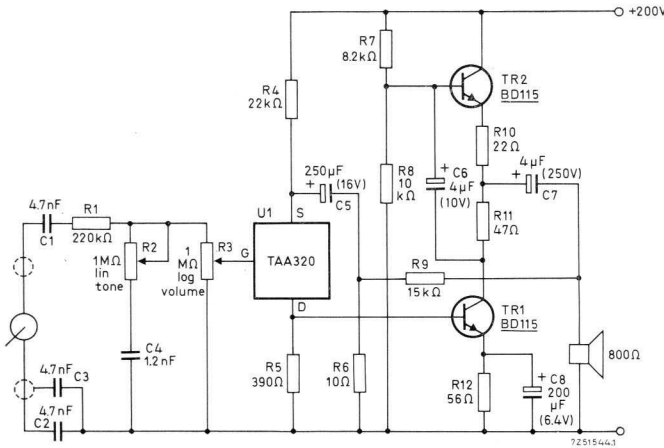

Fig. 4.19. Circuit diagram of four watt pick-up amplifier.

circuit TAA320, in which two BD115 transistors are connected in a single-ended Class-A push-pull configuration. Since the output transistors are effectively in series for d.c., a supply voltage of about 200 V is required. The drive signal for the upper transistor is obtained from the voltage drop across the collector resistor of the lower one.

The a.c. collector load is 800 Ω , so that either an 800 Ω loudspeaker, or an output transformer must be used.

With the exception of the output stage, this circuit is similar to the two

watt amplifier described under Circuit 28. Distortion as a function of output power is given in Fig. 4.20.

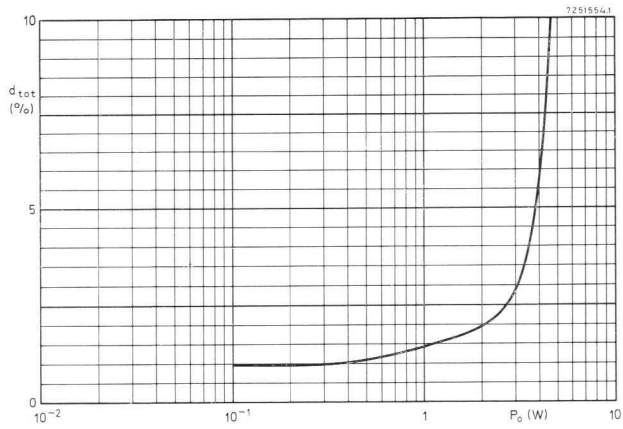

Fig. 4.20. Total distortion of the four watt amplifier at 1 kHz.

4.2.4 CIRCUIT 30 — FOUR WATT TRANSFORMERLESS CAR RADIO AMPLIFIER USING THE TAA435 AND AD161/162 OUTPUT TRANSISTORS

Performance specification:

	4 W into 5 Ω load	
	$R_4 = 220 \Omega$	$R_4 = 1 \text{ k}\Omega$
nominal power output		
sensitivity (1000 Hz)		
for $P_o = 4 \text{ W}$	15 mV	65 mV
for $P_o = 50 \text{ mW}$	1.7 mV	7.3 mV
input impedance	220 kΩ	
frequency response (-1.5 dB)	< 30	to 20000 Hz
total harmonic distortion at $P_o = 4 \text{ W}$ (from 40 Hz to 12.5 kHz)	≤ 1.0 %	≤ 0.6 %
unweighted signal/noise ratio (ref. $P_o = 50 \text{ mW}$)	50 dB	59 dB
weighted signal/noise ratio (ref. $P_o = 50 \text{ mW}$)	58 dB	68 dB
internal resistance at output socket	0.21 Ω	0.11 Ω
damping factor with 5 Ω speaker	23.8	45.4
nominal supply voltage	14 V	

Fig. 4.21 gives the circuit of a four watt amplifier which combines a TAA435 with AD161/162 transistors. This combination provides an excellent transformerless amplifier which follows the car radio trend

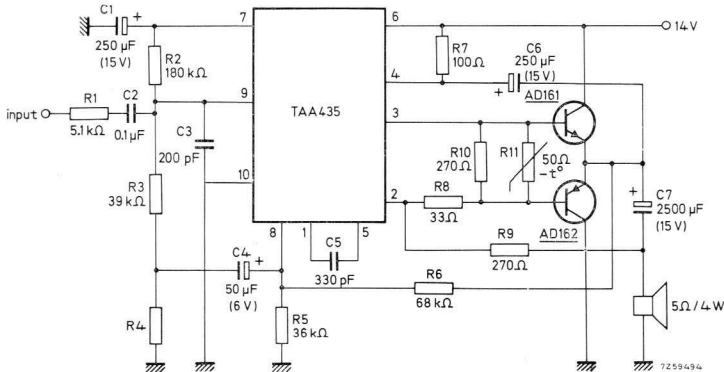

Fig. 4.21. Circuit diagram of four watt car radio amplifier.

to smaller size. There are two versions of the amplifier in which different values of negative feedback resistors are used.

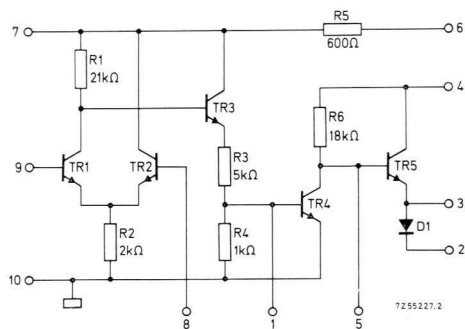

Fig. 4.22. Circuit of the TAA435.

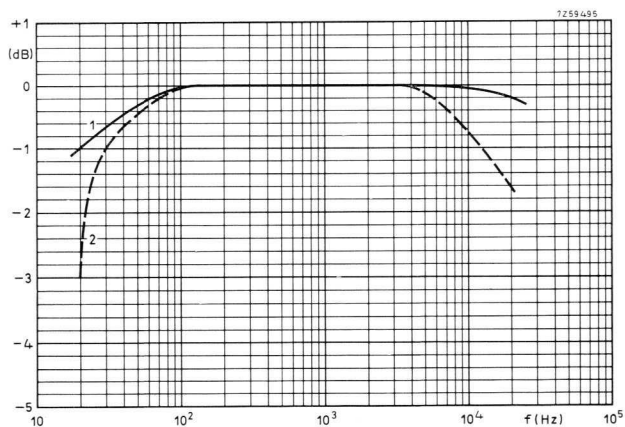

Fig. 4.23. Frequency response characteristic of the four watt car radio amplifier. $0\text{ dB} = 2\text{ V}$. Curve 1: with $1\text{ k}\Omega$ feedback resistor; Curve 2: with $220\ \Omega$ feedback resistor.

An integrated circuit TAA435 is employed serving as pre-drive and driver stage for the complementary symmetry output stage which uses AD161/162 transistors. Fig. 4.22 shows the circuit of the TAA435.

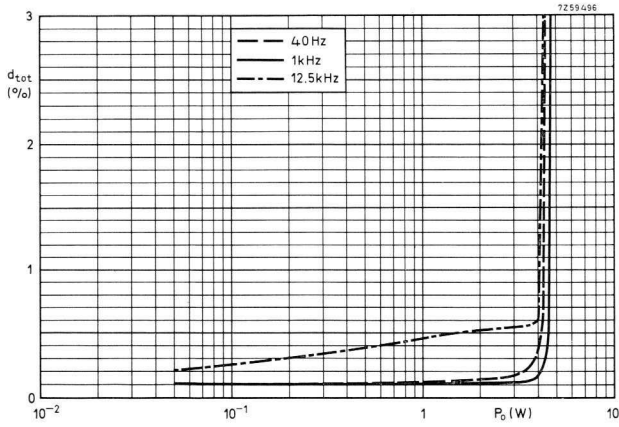

Fig. 4.24. Total distortion of the four watt car radio amplifier, where $R_4 = 1 \text{ k}\Omega$.

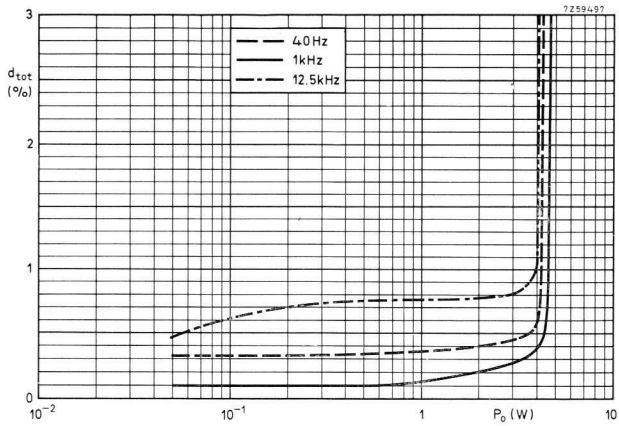

Fig. 4.25. Total distortion of the four watt car radio amplifier, where $R_4 = 220 \Omega$.

With a value of $220\ \Omega$ for the feedback resistor R_4 , an input sensitivity of 15 mV for 4 W output will be obtained. This value is adequate for all normal applications except a magnetic pick-up. A considerable im-

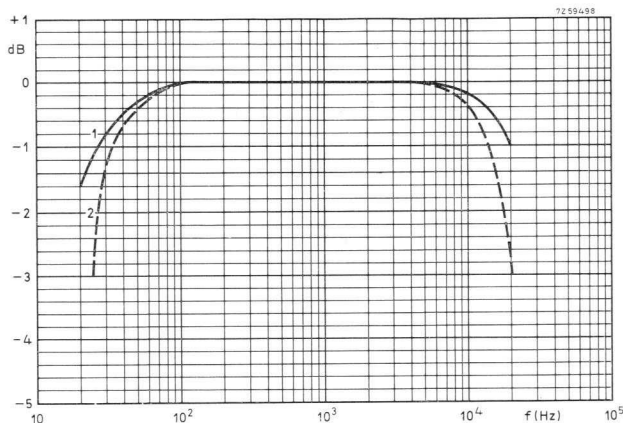

Fig. 4.26. Power bandwidth characteristic of the four watt car radio amplifier. $0\ \text{dB} = 4.6\ \text{W}$.

Curve 1: with $1\ \text{k}\Omega$ feedback resistor;
 Curve 2: with $220\ \Omega$ feedback resistor.

provement in performance is, however, obtained by increasing the negative feedback and it is recommended that unless a sensitivity of 15 mV is essential, R_4 should be increased to $1\ \text{k}\Omega$.

The frequency response characteristic is given in Fig. 4.23 for the two values of feedback resistor. Figs. 4.24 and 4.25 show the total harmonic distortion at three frequencies, 40 Hz, 1 kHz and 12.5 kHz, for $R_4 = 1\ \text{k}\Omega$ and $R_4 = 220\ \Omega$, respectively. The power bandwidth characteristics are given in Fig. 4.26.

4.2.5 CIRCUIT 31 — RECORDING AND PLAYBACK AMPLIFIER USING THE TAA310 INTEGRATED CIRCUIT

Fig. 4.27 shows a block diagram of a complete tape recorder incorporating the TAA310 which has been designed for operation as a recording

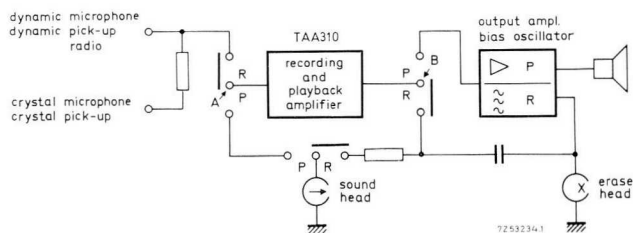

Fig. 4.27. Block diagram of tape recorder using the TAA310.

R = record, P = playback. Points A and B refer to input and output respectively of the circuit shown in Fig. 4.28.

and playback pre-amplifier with a tape speed of 4.75 cm/s (1-7/8 in/s) and an operating voltage of 7.0 V.

The circuit of the recording and playback amplifier is given in Fig. 4.28 and that of the TAA310 in Fig. 4.29. The first transistor of the input stage is a low noise transistor with a maximum wideband noise of 4 dB measured in a bandwidth from 30 Hz to 15 kHz. The current setting (100 μ A) of this transistor is chosen as a compromise between gain, input impedance and noise performance.

During recording the volume is controlled between the first and second transistor by R_2 , the slider of which is earthed, and a control range of approximately 70 dB is achieved.

Transistors TR_3 and TR_4 form a differential amplifier. This type of circuit was chosen because it is a simple method of obtaining effective negative feedback for both a.c. and d.c. Only TR_3 is involved in amplification, whilst TR_4 serves for the negative feedback. The operating points of TR_3 and TR_4 are set so that approximately the same currents (0.35 mA) flow in both transistors.

The operating point of the output transistor TR_5 must be located in the centre of the load lines so that the highest possible undistorted power output can be obtained. A strong d.c. negative feedback applied to

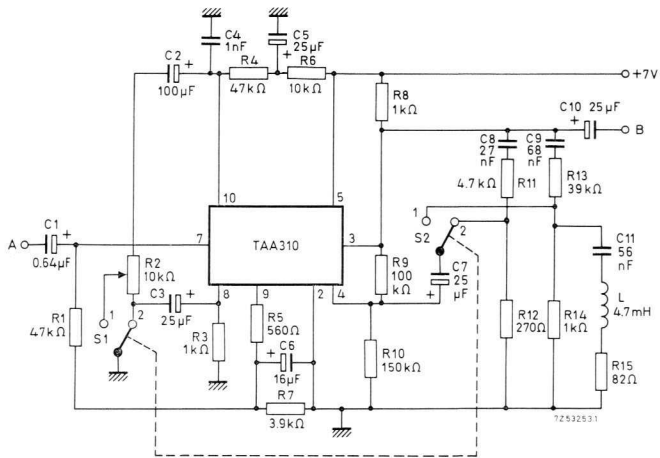

Fig. 4.28. Circuit diagram of the recording and playback amplifier. Switches S_2 and S_1 are in position 1 for recording and position 2 for playback.

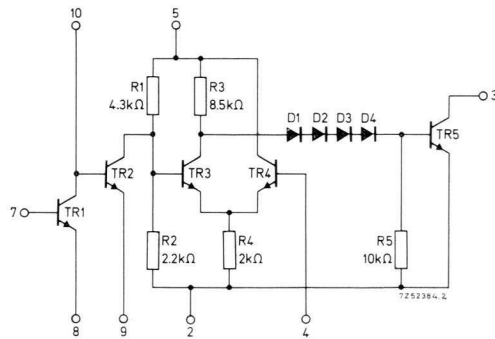

Fig. 4.29. Circuit of the TAA310.

TR_4 of the differential stage causes the operating point to adapt itself automatically to the supply voltage.

If the recording head of a tape-recorder is fed with a current of constant amplitude, the voltage delivered by the sound head on playback is

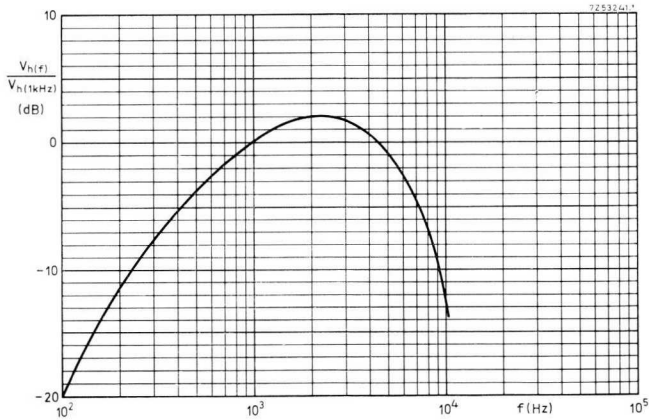

Fig. 4.30. No-load voltage of playback head as a function of frequency.

strongly frequency dependent. The dependency of the playback voltage on the frequency is shown in Fig. 4.30 for a tape speed of 4.75 cm/s ($1\text{-}7/8$ in/s).

For low frequencies, the voltage rises almost linearly with the frequency because for these frequencies the tape flux is constant and the voltage induced in the head is proportional to the change in flux $d\Phi/dt$. Above 2 kHz there is a decrease in the induced voltage with rising frequency due to the self-demagnetisation of the tape, the gap width of the head and the iron losses.

The 3 dB points of the overall amplitude response of a home tape recorder at a tape speed of 4.75 cm/s ($1\text{-}7/8$ in/s) should be at 80 Hz and 6300 Hz. The overall amplitude response should lie within the tolerance zone shown in Fig. 4.31.

In order to meet these requirements, the frequency response shown in Fig. 4.30 must be corrected. Switchable equalizing networks in the

recording/playback amplifier ensure the required increase in the treble (13 dB) during recording and in bass (17 dB) during playback (dB values with respect to 1000 Hz). The nature and range of correction are standardized so that the tapes played on different recorders are interchangeable. Fig. 4.32 shows the negative feedback equalizing networks employed, whilst Fig. 4.33 shows the frequency responses obtained. The load resistance of the amplifier will differ for each source and, since no single

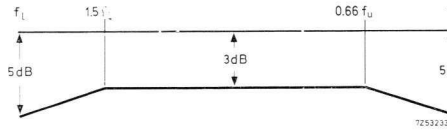

Fig. 4.31. Tolerance zone of overall amplitude response.

network can be used, it is necessary to calculate the values of the input load resistances required. To ensure that a flat characteristic of the loaded signal source is obtained and high frequency attenuation is avoided, the -3 dB point of the characteristic should be at a much higher frequency and if a value of 30 kHz is taken the overall amplitude characteristic at 6.3 kHz will then be scarcely affected.

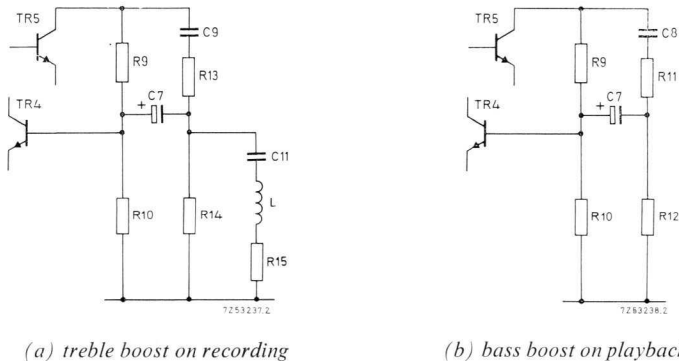
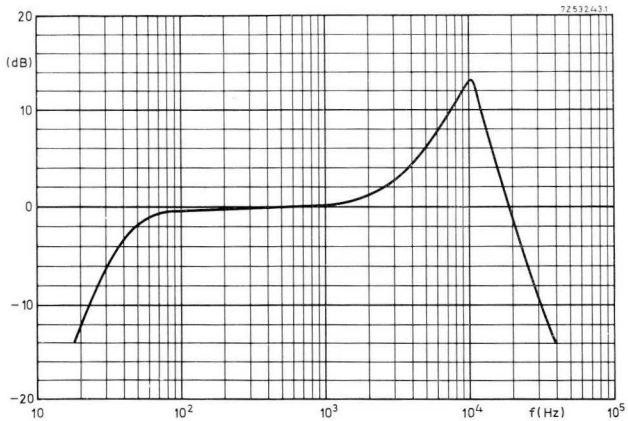
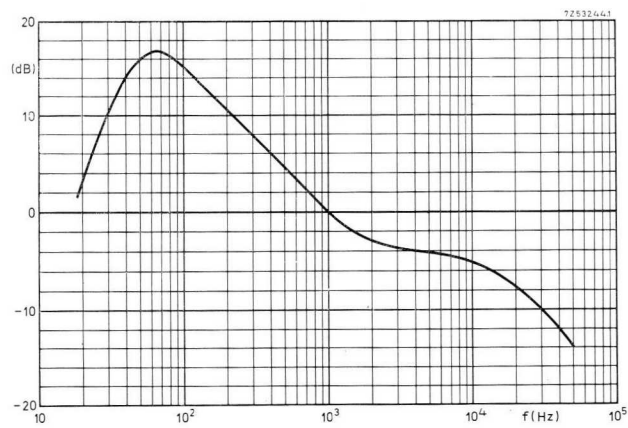

Fig. 4.32. Negative feedback equalization networks.



(a) recording amplifier



(b) playback amplifier

Fig. 4.33. Frequency response characteristics.

As an example, two of the required load resistances will be calculated. For the radio input, it should be assumed that the cable between radio and tape recorder has a length of 2 m and a capacitance of 40 pF/m. The load resistance that should not be exceeded is

$$R_1 = 1/(2\pi f_{-3dB}C) = (2\pi \times 3 \times 10^4 \times 8 \times 10^{-11})^{-1} = 66 \text{ k}\Omega$$

For the playback head input, the series inductance of the head ($L = 40 \text{ mH}$) will determine the high frequency roll-off. Here the required load resistance will be

$$R_1 = 2\pi f_{-3dB}L = 2\pi \times 3 \times 10^4 \times 4 \times 10^{-2} = 7.5 \text{ k}\Omega,$$

at least. Table 4.1 gives the source resistance of various signal sources together with their e.m.f. and required load resistances.

Volume control cannot be incorporated in the input network of the amplifier because it would entail an unacceptable noise and hum level,

Table 4.1. Values of Load Resistance for Different Signal Sources

signal source	source impedance	e.m.f.	required load resistance
radio (from detector)	0.5 M Ω	1 V	< 50 k Ω
crystal pick-up	3 nF	1.6 V	> 0.5 M Ω
dynamic pick-up	80 k Ω	1 to 2 V	10 k Ω
crystal microphone	1.5 nF	5 mV	> 1 M Ω
dynamic microphone	200 Ω	0.5 mV*	10 k Ω
playback head	L = 40 mH R = 100 Ω	typ. 0.5 mV min. 0.375 mV	> 8 k Ω

* At a sound pressure of 1 μ bar (normal speech at a distance of 0.5 m from the microphone).

especially when the available input signal power is low (dynamic microphone). As a result some of the input sources with a higher power level, such as radio, will tend to overload the input. Without precautions and because the chosen system of volume control also influences the negative a.c. feedback at the emitter of TR_1 , the input resistance might attain values higher than 50 k Ω (depending on the setting of the volume control). The requirement to keep the input resistance of the amplifier below 50 k Ω will be met by shunting a 47 k Ω resistance across the input. The lowest input resistance will then be 8.3 k Ω . The input impedance is

thus made suitable for playback, radio, dynamic microphone, and dynamic pick-up.

For the crystal pick-up and crystal microphone inputs the required load resistances are determined by the permissible attenuation of the input voltage at lower frequencies. Because the input resistance of the amplifier will be chosen between 8 and 50 k Ω (playback and radio recording), the required input resistance for crystal pick-up and crystal microphone ($< 1 \text{ M}\Omega$) will have to be obtained by means of an extra resistor which will then have to be switched in series with the input.

The output requirements of the amplifier are for playback 0.6 V (line output) and for recording 0.75 V across 5 Ω . The playback head (same as recording head) is fully modulated with 150 μA at 1 kHz (the bias current is 1 mA at 35 kHz). To get full magnetization at high frequencies without overmodulation at low frequencies a current drive of the head is required. With the amplifier described this current drive can be realized by connecting a resistance of 5 k Ω in series with the head. Full magnetization thus requires an r.m.s. voltage of 0.75 V across this series combination.

From Table 4.1 it can be seen that the input is lowest for recording with a dynamic microphone (0.5 mV). Because the input resistance of the amplifier is high in relation to the source impedance of a dynamic microphone, it may be assumed that the full e.m.f. of the microphone is available at the input. For recording, the required voltage gain will thus be $G_v = 0.75/(0.5 \times 10^{-3}) = 1500$ (64 dB). To this must be added 13 dB for treble correction, which makes the total $G_v = 64 + 13 = 77$ dB.

During playback the required voltage gain is $G_v = 0.6/(0.375 \times 10^{-3}) = 1600$ (64.5 dB) for a minimum head, to which gain an extra 17 dB must be added for bass correction. Thus the total gain during playback has to be at least $64.5 + 17 = 81.5$ dB. In addition, a further gain reserve is desirable to minimize the effects of spreads between the individual integrated circuits on gain by means of appropriate negative feedback. The minimum gain of the amplifier described here is 83 dB.



A selection of the high quality and high fidelity loudspeakers which are used to build the recommended systems.

5. Loudspeaker Systems

5.1 Principles of Loudspeaker Selection

5.1.1 SURVEY OF LOUDSPEAKERS

The selection of a loudspeaker for a reproducing system is determined by a number of factors, including the frequency range required, the permissible distortion, the power requirements and the method of mounting the speaker.

For applications where a restricted frequency range is adequate, such as with inexpensive radios, record-players and tape recorders, the *Standard* range of loudspeakers offers a wide choice. The resonance frequencies of these speakers varies from 75 Hz for an 8-inch unit, to 360 Hz for a 2.5-inch unit. High frequency roll-off is extended to 10 kHz for a few types. These are listed in Table 5.1.

Where a wider frequency band is required the *High Quality* range of speakers given in Table 5.2 provides an excellent solution. These speakers are all double-cone full-range types and, with exception of the 5-inch and 7-inch units, they have high sensitivity due to the powerful Ticonal magnets used. This range of speakers is intended for use in acoustic enclosures of good quality sound installations.

Finally, there is the *High Fidelity* range of speakers given in Table 5.3. For these, the frequency band is divided by means of a cross-over filter network. The specially designed bass units, or *woofers*, provide an excellent low frequency response when mounted in the recommended enclosures. Each woofer has a very low resonance frequency, that of the 12-inch woofer being only 19 Hz. High frequency units, or *tweeters*, are also available and a smooth frequency characteristic to 20 kHz will be obtained with the 1-inch tweeter. It is therefore possible to obtain an overall frequency characteristic, matching that of the high fidelity amplifiers, with this range of speakers.

The most irritating kind of distortion is that occurring at high frequencies on transients. The 1-inch tweeter, which operates on the same principle as all moving coil speakers, uses a specially contoured thermo-plastic diaphragm resembling part of the surface of a sphere instead of a cone. This results in negligible interference between the waves leaving the surfaces of the "dome" and a smooth polar response is obtained as shown in Fig 5.1. Because the moving parts of the tweeter are extremely

Table 5.1. Standard Range of Loudspeakers

overall diameter (mm)	total depth (mm)	power handling capacity (W)	impedance (Ω)	resonance frequency (Hz)	total flux (μ Wb)	flux density (mT)	type number
2½'' round 64	20	0.5	4 8 15 25	360	63	740	AD2070/Z4 AD2070/Z8 AD2070/Z15 AD2070/Z25
3'' round 81	28	1.0	4 8 15 25	250	63	740	AD3070/Y4 AD3070/Y8 AD3070/Y15 AD3070/Y25
81 □	28	1.0	150	250	63	740	AD3370/Y150
4'' round 105	29	1.0	4 8 15 25	200	63	740	AD4070/Y4 AD4070/Y8 AD4070/Y15 AD4070/Y25
105	39	3.0	4 8 15 25	165	177	1000	AD4080/X4 AD4080/X8 AD4080/X15 AD4080/X25
105	37	2.0 2.0 0.6	8 15 400	180 175 190	118	1000	AD4090/X8 AD4090/X15 AD4090/X400
5'' round 129	48	3 W	4 8 15 25	155	180	1000	AD5080/Z4 AD5080/Z8 AD5080/Z15 AD5080/Z25
		4 W	4 8 15 25	130			AD5080/M4 AD5080/M8 AD5080/M15 AD5080/M25
		6 W	4 8 15 25	140			AD5080/X4 AD5080/X8 AD5080/X15 AD5080/X25

Table 5.1. (continued)

overall diameter (mm)	total depth (mm)	power handling capacity (W)	impedance (Ω)	resonance frequency (Hz)	total flux (μ Wb)	flux density (mT)	type number
7'' round 166	47	3 W	4	115	189	700	AD7091/X4
			8				AD7091/X8
	58	4 W	800	95	175	980	AD7091/X800
			4				AD7091/M4
			8				AD7091/M8
			800				AD7091/M800
6 W	4	105				AD7080/M4	
	8					AD7080/M8	
6 W	4	115				AD7080/X4	
	8					AD7080/X8	
8'' round 206	68	6 W	4	95	177	980	AD8080/X4
			8				AD8080/X8
			4	75			AD8080/M4
			8				AD8080/M8
3'' \times 5'' oval 76 \times 131	42	2	4	200	118	1000	AD3590/X4
			8				AD3590/X8
			15				AD3590/X15
			50				AD3590/X50
			400				AD3590/X400
3'' \times 8'' oval 83 \times 206	51	2	4	120	177	1000	AD3880/X4
8							AD3880/X8
54	2		15	120			AD3880/X15
			4				AD3890/X4
			8				AD3890/X8
			800	125			AD3890/X800
4'' \times 6'' oval 102 \times 154	48	3	4	155	180	1000	AD4680/Z4
			8				AD4680/Z8
			15				AD4680/Z15
			25				AD4680/Z25

Table 5.1. (continued)

overall diameter (mm)	total depth (mm)	power handling capacity (w)	impedance (Ω)	resonance frequency (Hz)	total flux (η Wb)	flux density (mT)	type number
4" \times 6" oval 102 \times 154	48	4	4	125	151	850	AD4680/M4
			8				AD4680/M8
			15				AD4680/M15
		25	AD4680/M25				
	52	6	4	140			AD4680/X4
			8				AD4680/X8
			15				AD4680/X15
		3	400	124			AD4680/X25
			800				AD4690/M400
			4				AD4690/M800
6	4	8	135	AD4690/M4			
		4		AD4690/M8			
5" \times 7" oval 133 \times 183	58	3	4	115	117	980	AD5780/X4
			8				AD5780/X8
			15				AD5780/X15
		25	AD5780/X25				
		4	4				100
	8		AD5780/M8				
	6	4	15	85			AD5780/M15
			25				AD5780/M25
			8				AD5780/M8
	6" \times 9" oval 161 \times 234	68	6	4			72
8				AD6980/X8			
4				85	AD6980/M4		
8					AD6980/M8		
8					AD6980/M8		

Table 5.2. High Quality Range of Loudspeakers

overall diameter (mm)	total depth (mm)	power handling capacity (W)	impedance (Ω)	resonance frequency (Hz)	total flux (μ Wb)	flux density (mT)	type number																																																																		
5"	56	6 ¹⁾	4	85	294	980	AD5060/M4 AD5060/M8																																																																		
			8					7"	70	10 ²⁾	5	55	426	950	AD7060/M5	5	8"	124	6	5	60	583	1300	AD8050/M5	5	8½"	114	10	7	50	980	800	9710/M	7	10"	136	10	7	50	980	800	AD1050/M7	7	12"	123	10	5	50	426	950	AD1260/M5	160	20	7	50	980	800	AD1250/M7	170	20	7	50	1340	1100	AD1255/M7	170	40	4	60	1210	1000	AD1255/HP4	
7"	70	10 ²⁾	5	55	426	950	AD7060/M5																																																																		
			5					8"	124	6	5	60	583	1300	AD8050/M5	5	8½"	114	10	7	50	980	800	9710/M	7	10"	136	10	7	50	980	800	AD1050/M7	7	12"	123	10	5	50	426	950	AD1260/M5	160		20	7	50	980	800	AD1250/M7	170	20	7	50	1340	1100	AD1255/M7	170	40	4	60	1210	1000	AD1255/HP4				8				AD1255/HP8	
8"	124	6	5	60	583	1300	AD8050/M5																																																																		
			5					8½"	114	10	7	50	980	800	9710/M	7	10"	136	10	7	50	980	800	AD1050/M7	7	12"	123	10	5	50	426	950	AD1260/M5	160		20	7	50	980	800	AD1250/M7	170	20		7	50	1340	1100	AD1255/M7	170	40	4	60	1210	1000	AD1255/HP4				8				AD1255/HP8									
8½"	114	10	7	50	980	800	9710/M																																																																		
			7					10"	136	10	7	50	980	800	AD1050/M7	7	12"	123	10	5	50	426	950	AD1260/M5	160		20	7	50	980	800	AD1250/M7	170	20		7	50	1340	1100	AD1255/M7	170	40	4	60	1210	1000	AD1255/HP4				8				AD1255/HP8																		
10"	136	10	7	50	980	800	AD1050/M7																																																																		
			7					12"	123	10	5	50	426	950	AD1260/M5	160		20	7	50	980	800	AD1250/M7	170	20		7	50	1340	1100	AD1255/M7	170	40	4	60	1210	1000	AD1255/HP4				8				AD1255/HP8																											
12"	123	10	5	50	426	950	AD1260/M5																																																																		
	160	20	7	50	980	800	AD1250/M7																																																																		
	170	20	7	50	1340	1100	AD1255/M7																																																																		
	170	40	4	60	1210	1000	AD1255/HP4																																																																		
				8				AD1255/HP8																																																																	

1) In sealed enclosure of 9 litres volume.

2) In sealed enclosure of 25 litres volume.

Table 5.3. High Fidelity Range of Loudspeakers

overall diameter (mm)	total depth (mm)	power handling capacity (W)	impedance (Ω)	resonance frequency (Hz)	total flux (μ Wb)	flux density (mT)	type number
1" tweeter 94	27	40 ¹⁾	4 8	1000	270	1200	AD0160/T4 AD0160/T8
2" tweeter 58	29	20 ¹⁾	4 8	800	69	690	AD2070/T4 AD2070/T8
5" woofer 129	56	10 ²⁾	4 8	50	390	930	AD5060/W4 AD5060/W8
7" woofer 166	74	20 ³⁾	4 8	28	450	960	AD7065/W4 AD7065/W8
8" woofer 206	93	20 ⁴⁾	4 8	28 ⁸⁾	450	900	AD8065/W4 AD8065/W8
10" woofer 261	153	40 ⁵⁾	4 ⁷⁾ 8	20	1300	900	AD1055/W4 AD1055/W8
12" woofer 315	170	40 ⁶⁾	4 8	19	1210	1070	AD1256/W4 AD1256/W8

1) Applies to a single tweeter, when this power is applied to the input of the recommended cross-over filter and the signal is in accordance with DIN 45573.

2) In a 3 litre sealed enclosure.

3) In a 7 litre sealed enclosure.

4) In a 25 litre sealed enclosure.

5) In a 40 litre sealed enclosure.

6) In a 80 litre sealed enclosure.

7) The 4 Ω version of the 10" woofer will become available later in the production programme.

8) The system resonance frequency is lower with this speaker than when the 7" woofer is used because the larger enclosure preferred with the 8" woofer results in reduced stiffness and the rise in the enclosure resonance frequency is less.

light in weight, virtually no time is lost in getting the diaphragm moving in response to a signal. The step-function response of the tweeter is therefore excellent, and it is able to handle high frequency transients without any noticeable distortion. When the 1-inch tweeter is correctly mounted and the recommended cross-over network is used, distortion is less than 1 % and is therefore inaudible.

Overloading is also a common cause of distortion, often due to bass-boosting the signal when the power handling capacity of the speaker has been reached but, provided that the frequency and power requirements are carefully studied before a choice of speaker is made, distortion should be a minimum. Development work aimed at reducing inherent distortion is constantly in progress and modern, well-designed speaker units employed in a *properly engineered system* can now be relied upon to contribute only a minute amount of distortion to the reproduced sound.

5.1.2 POWER REQUIREMENTS

The maximum loudness level depends on the background noise in the listening room and the dynamic range of the reproduced programme. Assuming a room noise level of 30 phons and a dynamic range of 60 dB, the maximum loudness level required will be 90 dB above threshold.

Because of the large number of variables affecting room acoustics it is only possible to approximate the power requirements. Realistic results can be obtained using the following simplified method of determination. The *acoustic* power at threshold at 1000 Hz can be taken to be

$$P_{threshold} = 4 \times 10^{-14} \frac{V}{T} \text{ watts,}$$

where V is the room volume in cubic metres and T is the reverberation time in seconds. For small rooms, up to say 100 m³, T has a value of approximately 0.5 seconds.

Assuming that the listening room measures 5 m long, 4 m wide and 3 m high, its volume will be 60 m³. For the maximum loudness level of 90 dB above threshold referred to above, the acoustic power level becomes:

$$P_{max} = \frac{4 \times 10^{-14} \times 60 \times 10^9}{0.5} = 4.8 \text{ mW.}$$

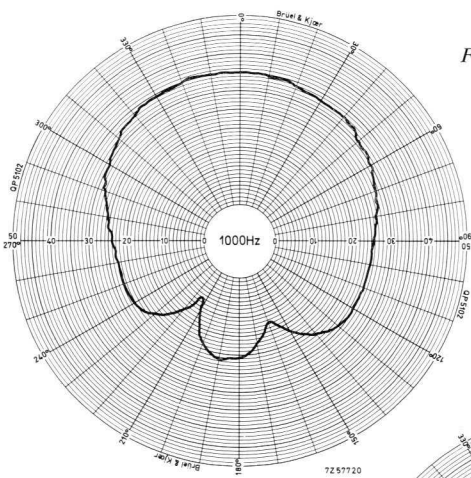

Fig. 5.1 (a). Polar response at 1000 Hz.

Fig. 5.1 (b). Polar response at 3000 Hz.

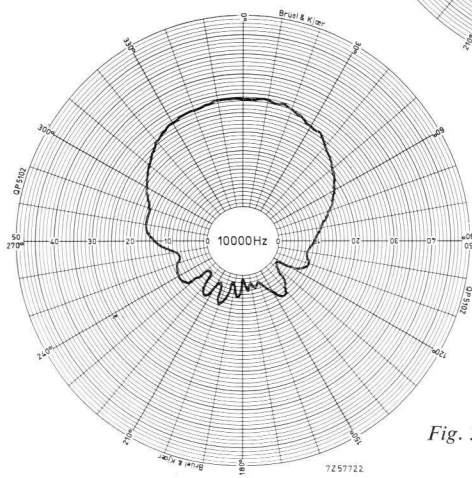
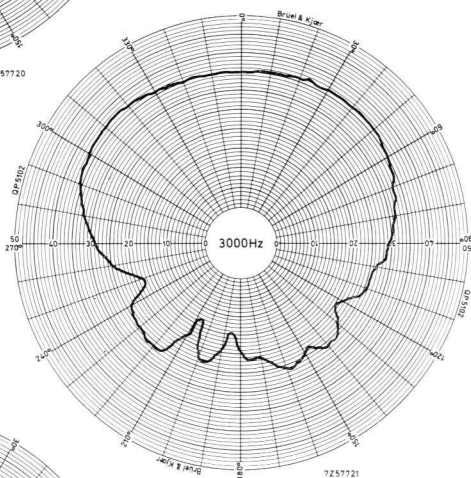

Fig. 5.1 (c). Polar response at 10000 Hz.

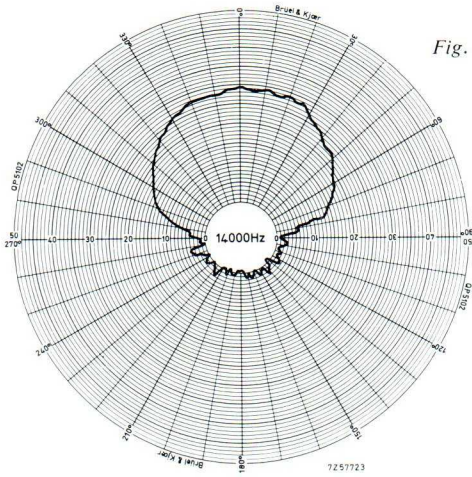

Fig. 5.1 (d). Polar response at 14000 Hz.

Fig. 5.1 (e). Frequency response curve of the AD0160/T.

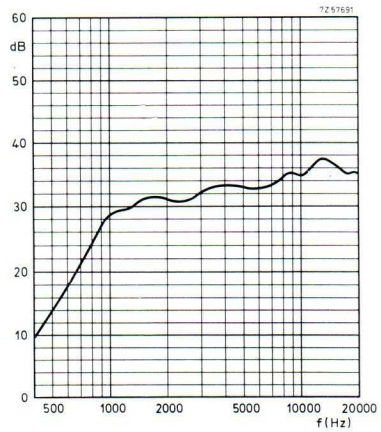
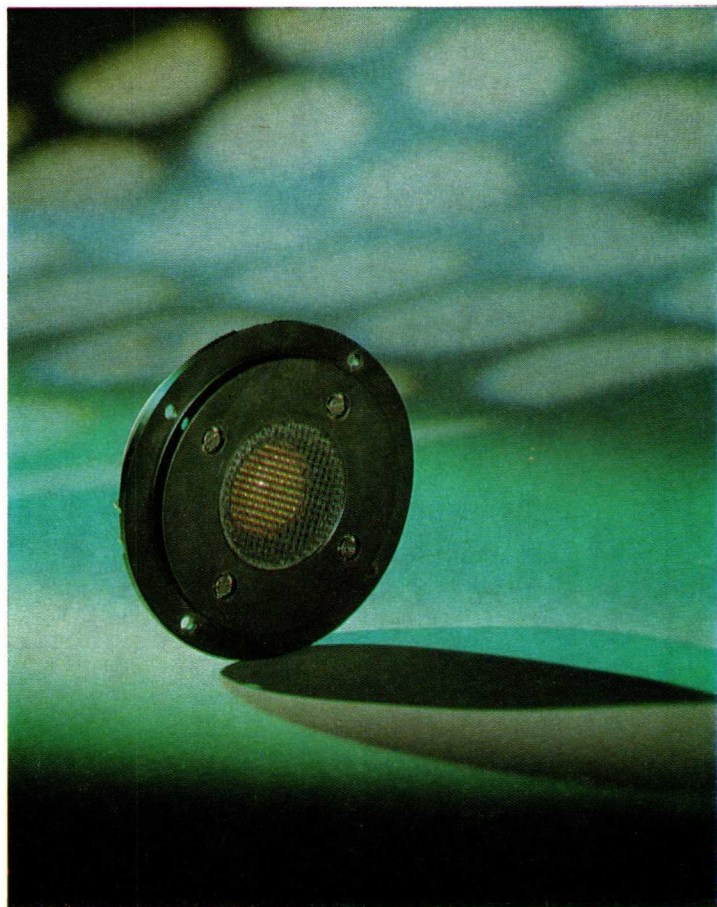

Fig. 5.1. Performance characteristics of the 1-inch tweeter, AD0160/T.



The one-inch "dome" tweeter gives superb reproduction of all frequencies from 1000 Hz to over 20 000 Hz. It has a dome-shaped diaphragm which gives a nearly ideal polar diagram and, because of the low mass of its moving parts, transient distortion is negligible.

Taking the efficiency of the speaker system as 1 %, the electrical power input required will be:

$$100 \times 4.8 \text{ mW} = 0.48 \text{ W}.$$

The following discussion is based on the desire to obtain the greatest realism in the reproduced sound and applies to only high fidelity installations. It is realised that there are very many applications where the specifications may be relaxed, but it is important to remember that the power handling capacity of the speaker must always be adequate, and preferably with a small margin, to accept the peak output power of the amplifier without distortion.

It can be seen from the Fletcher-Munson contours in Fig. 2.1 on page 4 that the 90 phon curve is substantially flat over the bass region and so the relatively low electrical power of 0.48 W in the above example will be adequate to reproduce the signal at a level of 90 dB above the 1000 Hz threshold over the *whole* band.

However, at 40 Hz the threshold is nearly 60 dB above the threshold at 1000 Hz and at low volume levels over the bass region the sensitivity of the reproducing system should be increased, otherwise the signal may be inaudible. The physiological volume control (contour) has this property and is a good solution, but it is more usual to employ bass boost using the normal tone controls to overcome this bass deficiency. A bass boost of around 20 dB maximum is normally provided but, unless a contour control is employed, the increase in output can occur at *all* signal levels, not only those of low volume. In order that distortion is prevented under bass boost conditions, the power handling capabilities of the system should be increased. In the example quoted, the power requirement becomes $0.48 \times 10^2 = 48 \text{ W}$.

The ear is more tolerant of high volume levels where stereo reproduction is concerned. If the calculated power requirement of 48 W is applied to each channel, the power handling capacity of each speaker system and the power output of each of the reproducing amplifiers under bass boost conditions should therefore be at least 48 W and the acoustic power requirements will be correctly satisfied for each channel individually. This does not mean that the full 96 W will ever be required at one time, since the total signal is divided between the two channels, but only that if *all* the signal is required on *one* channel there will be adequate output to meet the acoustic power requirements.

Such is the ideal case, but in practice the power requirements can normally be reduced. By how much depends on the positioning of the speakers. When a speaker is mounted close to a wall the effective radiating area is theoretically doubled at low frequencies, owing to the reflection of the wall. A room corner has three mutually perpendicular surfaces and thus the effective radiating area for a corner speaker is doubled three times. A gain of 8 would, however, only be possible if the surfaces had a reflectance of 100 % and, allowing for the absorption of the walls, together with that of fitted carpet, adjacent curtains, etc., which reduce the effect, a reflectance of 50 % would be more likely. In practice, a gain of from 2 to 4 times (3 dB to 6 dB) can be expected. The power requirements of the system can thus be reduced by this amount and, in the example quoted, the 2×48 W system could be reduced to 2×25 W. The system will be operating at a *very much lower level* than this most of the time. Individual cases vary, however, and the speaker positioning and room absorption should be carefully considered before the calculated power requirements are modified.

The mono case is slightly different. An intensity level of 90 phons when reproduced by a mono system sounds very much harder and more irritating than when stereo is employed, or when it is produced by a live orchestra, since the directional discrimination of the ears is of no importance as the sound is emitted from one small source. This leads to a preference for reduced levels of loudness and smaller frequency range with mono reproduction. Something less than the calculated power level of 48 W will be required and in practice a 40 W installation would be considered *very* satisfactory. Again, the system will be operating at a very much lower level most of the time.

Speakers are tested by applying a signal, of the same spectrum as shown in Fig. 5.2, to the speech coil. The signal is obtained from a "white" noise generator, via a special filter, and corresponds to a frequency distribution approximately that of the relative acoustic power levels arising in speech and music (DIN45573). The power handling capacities given in the Tables are, therefore, for an input signal in conformity with the frequency distribution of Fig. 5.2. The power handling capacity of the tweeters, however, also depends on the cross-over frequency and the higher this is the greater will be the power handling capacity. For the 1-inch tweeter AD0160/T, the power handling capacity is 40 W (input to the filter) for a cross-over frequency of 4000 Hz, or 20 W for a cross-over frequency of 1500 Hz.

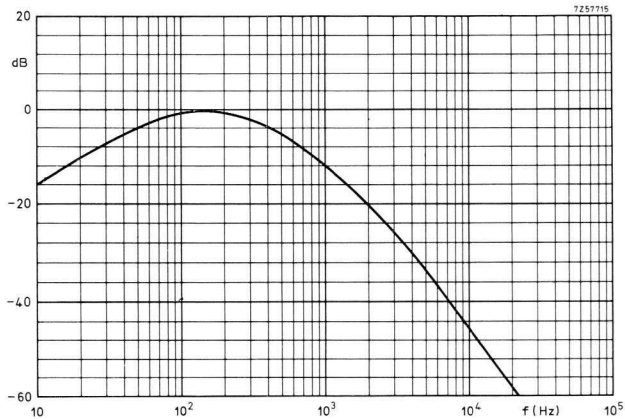

Fig. 5.2. Relative acoustic power levels arising in speech and music (DIN 45573).

5.1.3 METHODS OF MOUNTING

The method of mounting a loudspeaker has a profound effect upon its performance. The frequency response and power handling capacity are particularly affected where sealed enclosures are employed.

The result of using a baffle board is to remove the effects of acoustic short-circuiting and thus improve the bass response. The larger the baffle board the greater will be the improvement.

Small open-back enclosures, or enclosures with a slotted or perforated panel at the rear, are an improvement on the open baffle but it is only when the enclosure becomes nearly air-tight that the performance is greatly modified. Vented enclosures such as the bass-reflex enable the volume of air to be used to control the acoustic response.

For good low frequency reproduction with a vented enclosure a large cabinet is necessary but, because of the trend toward miniaturization, the original bass-reflex enclosure has fallen out of favour on account of its size. A modern loudspeaker, specially designed for use in a sealed enclosure, can produce a comparable frequency response to that obtained with the older bass-reflex in a fraction of the volume. The design of sealed enclosures is discussed briefly below.

5.2 Sealed Enclosures for Hi-Fi Systems

5.2.1 PRINCIPLES OF DESIGN

Under "free-space" conditions, normally achieved only in an anechoic room, the resonance frequency of a loudspeaker is given by:

$$f_o = \frac{1}{2\pi} \sqrt{\frac{S_s}{M_d}}, \quad (5-1)$$

where S_s is the stiffness of the speaker cone and suspension and M_d is the dynamic mass.

The dynamic mass, $M_d = M_c + M_a$, where M_c is the mass of the moving parts and M_a is the mass of the air moved on both sides of the cone.

From eq. (5-1), the stiffness of the speaker may be calculated:

$$S_s = 4\pi^2 f_o^2 M_d. \quad (5-2)$$

The method of determining both the stiffness and the dynamic mass is to take two measurements. Firstly, the resonance frequency f_o is found by applying a controlled signal to the speaker in an anechoic room. A known mass m is then applied to the cone and the new lower resonance frequency, f_m , is determined. From eq. (5-2),

$$S_s = 4\pi^2 f_m^2 (M_d + m). \quad (5-3)$$

Since the value of the stiffness S_s was the same during both measurements, eqs (5-2) and (5-3) may be combined, from which

$$4\pi^2 f_m^2 (M_d + m) = 4\pi^2 f_o^2 M_d$$

and

$$M_d = \frac{mf_m^2}{f_o^2 - f_m^2}. \quad (5-4)$$

The value of M_d obtained from eq. (5-4) may be substituted in eq. (5-2) and hence the stiffness S_s calculated. Typical values of mass and stiffness are given in Table 5.4.

When the speaker is mounted in a sealed enclosure, at low frequencies the internal volume of the enclosure will act as a stiffness which must be added to the stiffness of the loudspeaker suspension system. This causes

the resonance frequency to rise. The new resonance frequency now becomes:

$$f_{sys} = \frac{1}{2\pi} \sqrt{\frac{S_s + S_b}{M_a}}, \quad (5-5)$$

where f_{sys} is the resonance frequency of the system as a whole, comprising the speaker and the enclosure, and S_b is the stiffness of the enclosure. Combining equations (5-1) and (5-5) the proportional increase in frequency becomes:

$$\frac{f_{sys}}{f_o} = \sqrt{\frac{S_s + S_b}{S_s}} = \sqrt{\left(1 + \frac{S_b}{S_s}\right)}. \quad (5-6)$$

Table 5.4. Values of Mass and Stiffness for High Fidelity Woofers

woofer type	nominal dia. (in)	effective piston dia. (mm)	M_c (g)	$M_a^{(1)}$ (g)	M_d (g)	S_s (N/m)	f_o (Hz)
AD5060	5	90	5	0.3	5.3	530	50
AD7065	7	120	13	0.7	13.7	430	28
AD8065	8	150	24	1.32	25.3	790	28
AD1055	10	190	28	2.0	30	480	20
AD1256	12	240	45	5.4	50.4	730	19

¹⁾ The air load may be calculated from the equation $M_a = 2 \times 0.135 \rho A^2 / r$, where ρ = density of the air, A = area of equivalent "piston" and r = cone radius.

The stiffness of an enclosure is given by:

$$S_b = \frac{\rho c^2 A^2}{V}, \quad (5-7)$$

where

ρ = density of the air,

c = velocity of sound,

A = area of the equivalent "piston",

V = enclosure volume.

The stiffness thus depends on the size of baffle hole and volume of the enclosure. The stiffnesses of enclosures for various woofers are given in Table 5.5.

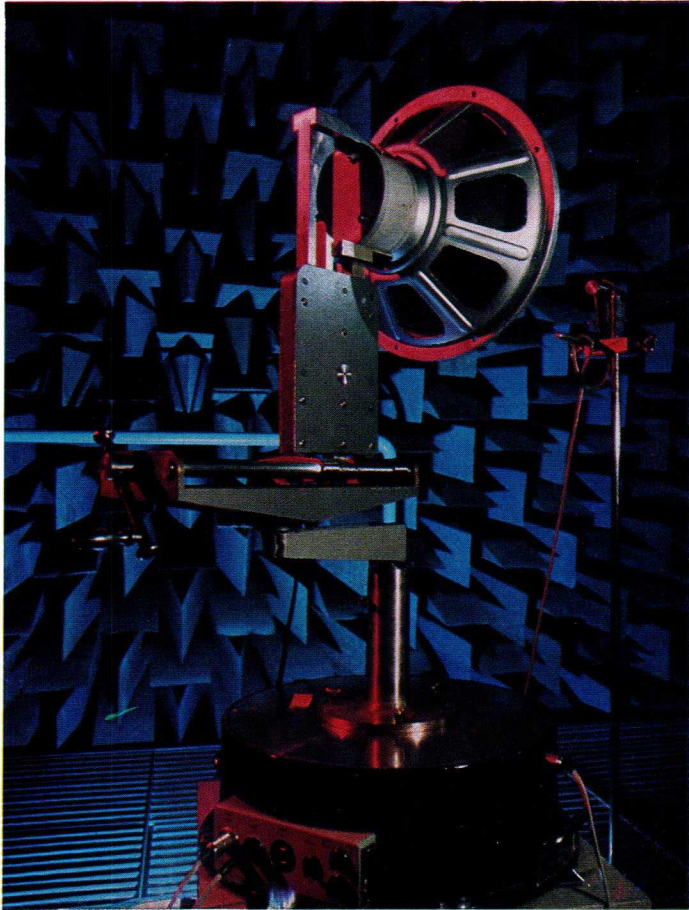

A high fidelity speaker on test in the anechoic room. The speaker is held in a clamp on the test fixture and the microphone positioned 50 cm away. The polyurethane 'wedges' which cover the walls and ceiling absorb all reflections and the room simulates 'free space' conditions. Wedges are also fitted on the floor below the metal grid.

Table 5.5. Stiffnesses of Various Sizes of Enclosures

enclosure volume (l)	woofer dia. (in)	stiffness S_b (N/m)
3	5	1900
7	7	2600
10	7	1820
15	7	1210
15	8	2900
20	8	2200
25	8	1750
35	10	2100
40	10	1830
50	12	5600
80	12	3500

If the woofer baffle hole is less than one-third the area of the baffle, the rise in the resonance frequency is approximately 7% less than that obtained from eq. (5-6) and the resonance frequency is then given by:

$$\frac{f_{sys}}{f_o} = \sqrt{0.87 \left(1 + \frac{S_b}{S_s} \right)}. \quad (5-8)$$

This is shown graphically in Fig. 5.3.

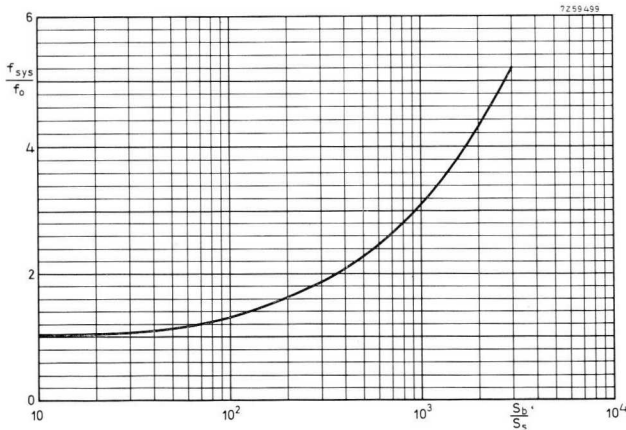

Fig. 5.3. Proportional rise in the resonance frequency of a loudspeaker when fitted in a sealed enclosure.

5.2.2 FREQUENCY RESPONSE AND ENCLOSURE VOLUME

The frequency response of a loudspeaker is determined by recording through a microphone, 50 cm away along the axis of the speaker, the response to a constant voltage signal of 50 mW (12-inch full range types 25 mW) as the frequency is swept slowly to 20000 Hz. The test takes place in an anechoic room and the result is plotted with a pen recorder. 0 dB on the response curve corresponds to 52 dB above the threshold of hearing (2×10^{-4} μ bar). Fig. 5.4 shows a typical response curve for a full range high quality speaker.

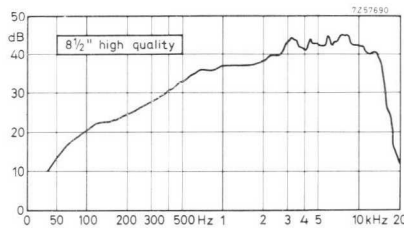

Fig. 5.4. Frequency response curve of a typical full-range loudspeaker, obtained without baffle in an anechoic room.

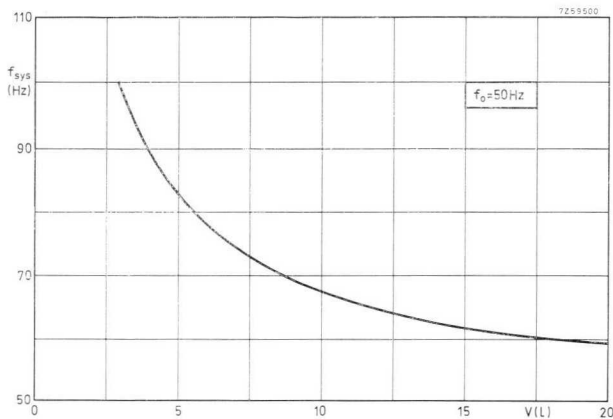

Fig. 5.5 (a). 5-inch woofer, AD5060/W.

Fig. 5.5. Variation in system resonance frequency with enclosure volume for typical samples of the high fidelity woofers.

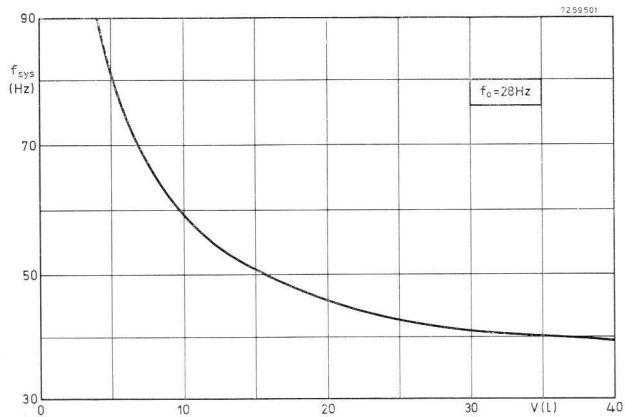

Fig. 5.5 (b). 7-inch woofer, AD7065/W.

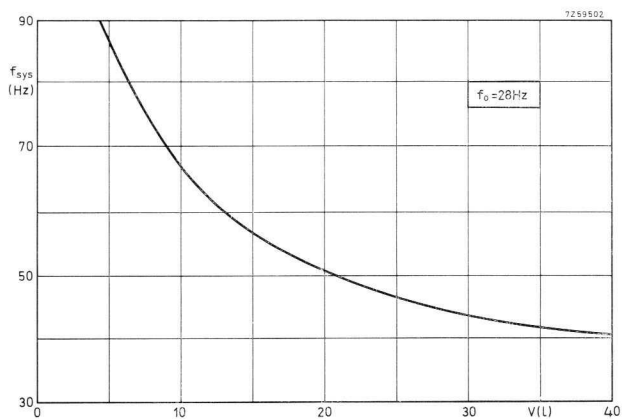

Fig. 5.5 (c). 8-inch woofer, AD8065/W.

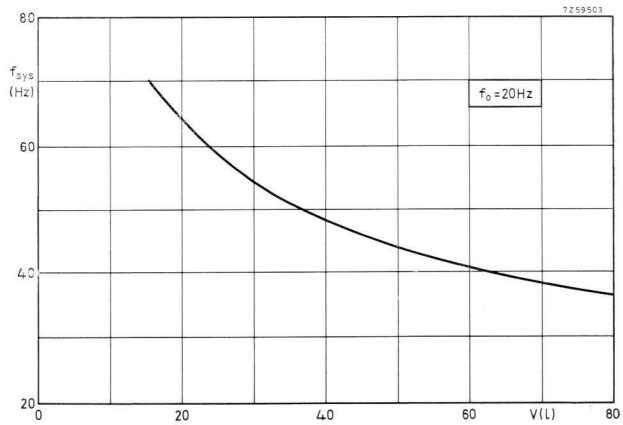

Fig. 5.5 (d). 10-inch woofer, AD1055/W.

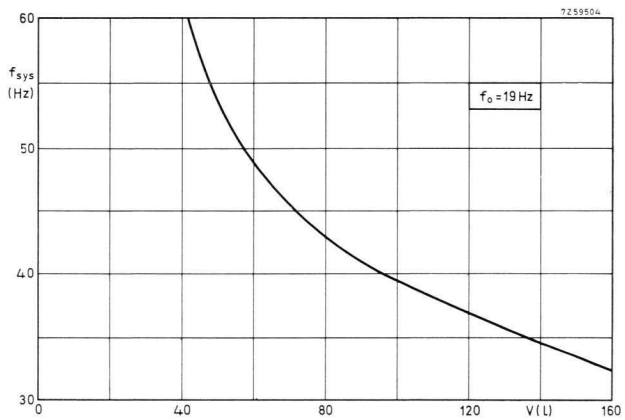

Fig. 5.5 (e). 12-inch woofer, AD1256/W.

When a loudspeaker is fitted into a sealed enclosure, its frequency response is considerably modified. For example, bass roll-off below resonance frequency which normally takes place at 18 dB/octave then becomes 12 dB/octave. The lower the resonance frequency of the speaker, and hence the combination of speaker and enclosure, the better will be the bass response. Fig. 5.5 shows the variation in resonance frequency with enclosure volume for typical samples of the high fidelity woofers.

The high fidelity standard DIN45500 defines the requirements for frequency response by reference to a standard curve, which is shown in Fig. 5.6. When a frequency response curve has been determined for a loudspeaker system, the curve of Fig. 5.6 is overlaid on it, the middle of the standard curve adjusted to the average of the loudspeaker system response. Provided that the system response lies within the upper and lower limits defined by the top and bottom lines respectively of the overlay, the frequency response conforms to the high fidelity standard.

Fig. 5.7 shows the frequency response curve of a loudspeaker system employing one 12-inch woofer, four 5-inch mid-range speakers and four 1-inch tweeters. It can be seen from Fig. 5.8 that the loudspeaker system conforms to DIN45500 when the standard curve is superimposed on the response curve.

For details of suitable enclosures the reader is referred to the Application Book "Building Hi-fi Speaker Systems". Although this book was written primarily for the hi-fi enthusiast, constructional details of 11 different enclosures are provided, together with the frequency characteristics of 24 speaker systems.

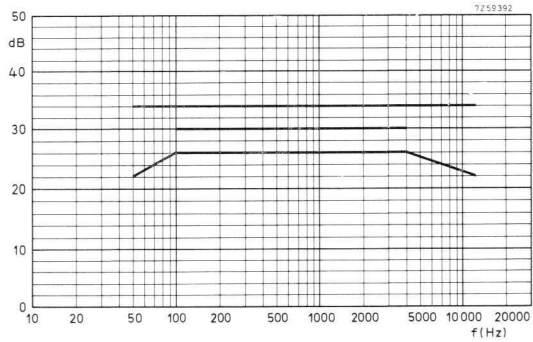

Fig. 5.6. Frequency response requirements to meet the high fidelity standard DIN 45500.

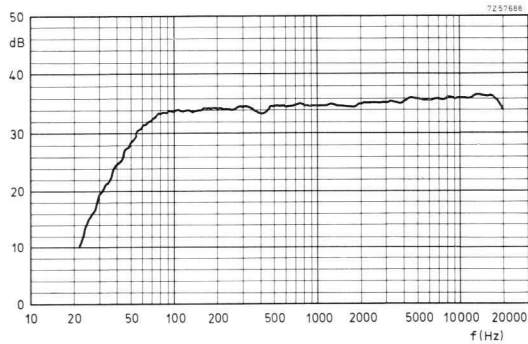

Fig. 5.7. Frequency response characteristic of sealed enclosure system employing a 12-inch woofer, four 5-inch mid-range speakers and four 1-inch tweeters.

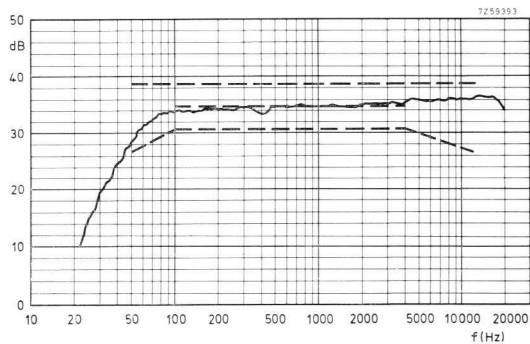

Fig. 5.8. Frequency response characteristic of Fig. 5.7 with the requirements of DIN 45500 superimposed. The loudspeaker system clearly meets the high fidelity standard.



In the laboratory outside the anechoic room the recorder plots the frequency response of the speaker under test. The signal fed to the speaker is swept from 20 Hz to 20000 Hz whilst the graph paper is fed through the recorder in synchronism. The amplitude of the response in the microphone controls the pen movement. When the polar response is required, the speaker is rotated in front of the microphone and a polar plotter is used, the test frequency remaining constant.

Appendix

Heat-sink Design and Calculations

Up to a certain point the junction temperature of a transistor rises linearly as a function of the power dissipated. The junction temperature T_j is given by:

$$T_j = T_{amb} + R_{th\ j-a} \cdot P_{tot}, \quad (\text{A-1})$$

where T_{amb} is the ambient temperature, $R_{th\ j-a}$ is the thermal resistance between the junction and its surrounding air, and P_{tot} is the total power dissipated.

The maximum junction temperature is usually given by the transistor manufacturer, the ambient temperature for which the equipment is intended is known by the designer, and the power dissipation can be calculated for the worst case of operating conditions.

The worst case dissipation for output transistors in a high fidelity Class-B configuration is given by:

$$P_{tot} = \frac{1.21 V^2}{\pi^2(0.8 R_L + R_E)}, \quad (\text{A-2})$$

where V is the total d.c. voltage across the transistor and emitter resistor (in complementary and quasi-complementary output circuits this is taken to be the mid-point voltage), R_L is the external load impedance and R_E is the emitter resistance. Equation (A-2) corresponds to a set of conditions in which the supply voltage is 10 % higher than nominal, an unfavourable sine-wave excursion, and a load impedance 20 % below the nominal value.

In order that the junction temperature shall not be exceeded it is necessary to calculate the thermal resistance between the junction and its surrounding air. Equation (A-1) can therefore be re-arranged as follows:

$$R_{th\ j-a} = \frac{T_j - T_{amb}}{P_{tot}}. \quad (\text{A-3})$$

The total thermal resistance between the junction and the ambient air can be given an equivalent circuit as shown in Fig. A.1.

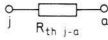

for low-power transistors using a mounting clip and heat-sink:

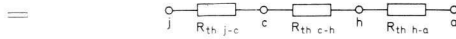

for high-power transistors:

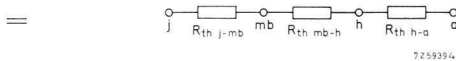

Fig. A.1. Equivalent thermal circuits for transistors.

In the case of small, low-power transistors no electrical connections are made to the case and the problems of electrical insulation do not arise. Hence a small cooling clip is normally employed which may be directly connected to the case of the transistor. If the heat transfer of the cooling clip is insufficient, the clip may be screwed to a heat-sink. For efficient heat transfer between the clip and the heat-sink it is very important that the correct force is applied to the screw in order that proper contact is maintained. The torque on the screw is therefore normally specified by the manufacturer of the cooling accessories. Heat transfer takes place by conduction and radiation, the different thermal resistances shown in Fig. A.1 take both forms of heat loss into account.

High-power transistors in complementary and quasi-complementary output stages have to be electrically insulated, since the collector is normally connected to the case. Hence it is usual to place a mica washer between the transistor mounting base and the heat-sink. In addition, insulating bushes are used for the mounting screws. Heat transfer first takes place from the mounting base, through the mica washer, to the heat-sink as shown by $R_{th\ mb-h}$, and then from the heat-sink to the ambient air.

Since a wide range of accessories for heat dissipation to suit all the transistors listed in this book is readily available, with precise data on their thermal resistances, the remaining problem is that of calculating the size of the heat-sink, if any, required. Since the values of $R_{th\ j-mb}$ and $R_{th\ mb-h}$ are known, the value of the unknown quantity $R_{th\ h-a}$ is given by:

$$R_{th\ h-a} = R_{th\ j-a} - (R_{th\ j-mb} + R_{th\ mb-h}). \quad (A-4)$$

The thermal resistance $R_{th\ h-a}$ depends on the power dissipation, the surface conditions, the mounting position and, in the case of flat heat-sinks, the thickness of the heat-sink and the type of envelope of the transistor. The dimensions and type of heat-sink may be determined by graphical means as shown in Fig. A.2. This graph is built up of four

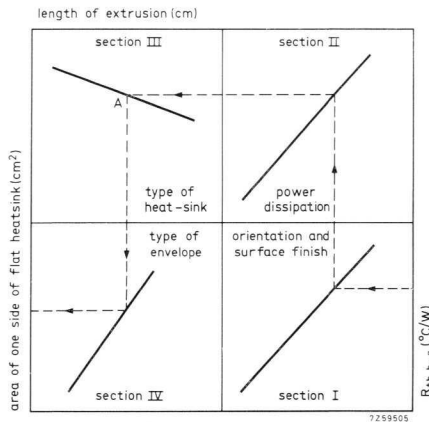

Fig. A.2. Showing how the heat-sink curves of Fig. A.3. are used. If the type of heat-sink is an extrusion, the line should be continued vertically upwards from point A in Section III to give the length of the extrusion.

sections. Section I shows the dependence of the thermal resistance on the orientation and surface finish of the heat-sink. Section II shows the influence of the power dissipation under conditions of free convection on the thermal resistance. Section III shows how the thermal resistance varies as a function of the area and thickness of the heat-sink (for flat heat-sinks), or the length (in the case of extruded heat-sinks). Section IV

shows how the envelope influences the thermal resistance, because with flat heat-sinks the total cooling area becomes larger.

Fig. A.3 gives the heat-sink curves, which apply to aluminium heat-sinks only. An example should make the use of them clear. Consider the BD181 output transistors of the 15 W amplifier described in Section 3.6.

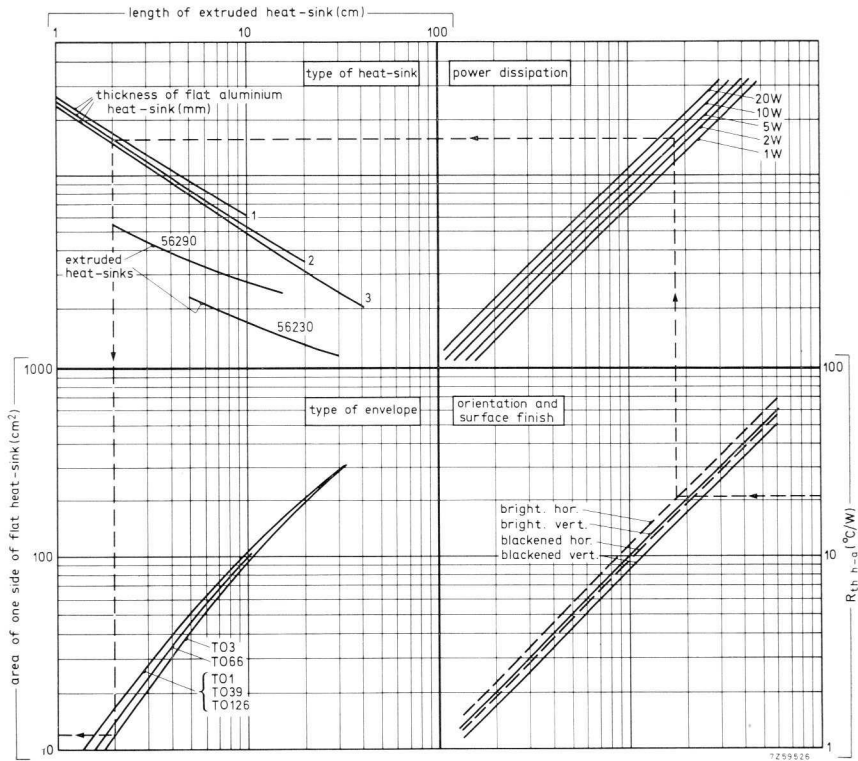

Fig. A.3. Heat-sink design curves for audio power transistors. The dotted line shows an example in which the required $R_{th\ h-a}$ is $20.75\text{ }^{\circ}\text{C/W}$, worst case dissipation is 6.5 W , and a 2 mm thick, flat, horizontal heat-sink of bright aluminium is used. For a transistor with a TO-3 envelope, it is shown that a heat-sink with a surface area (one side) of 12 cm^2 is required.

From equation (A-2), the worst case dissipation is given by:

$$P_{tot} = \frac{1.21 \times 19^2}{\pi^2(6.4 + 0.47)} = 6.5 \text{ W},$$

since the mid-point voltage is 19 V, the external load impedance is 8 Ω and the emitter resistor is 0.47 Ω .

Assuming that the amplifier is designed for a maximum temperature of 50 °C, then for a maximum junction temperature of 200 °C for a BD181 (from Table 3.3), the value of $R_{th\ j-a}$, from equation (A-3), becomes:

$$R_{th\ j-a} = \frac{200 - 50}{6.5} = \frac{150}{6.5} = 23^\circ \text{C/W}.$$

From Table 3.3, the $R_{th\ j-mb}$ for the BD181 is 1.5 °C/W. The recommended mounting accessory Cat. No. 56201e, which includes a lead and a mica washer, has a $R_{th\ mb-h}$ of 0.75 °C/W. From equation (A-4), the value of $R_{th\ h-a}$ becomes:

$$R_{th\ h-a} = 23 - (1.5 + 0.75) = 20.75^\circ \text{C/W}.$$

Entering Fig. A.3 at this value of $R_{th\ h-a}$ in Section I and moving horizontally until the curve for a bright horizontal heat-sink is reached, a vertical line is then drawn to intersect the 6.5 W power curve in Section II. By interpolation between the 5 W and 10 W curves a point is obtained from which a horizontal line is drawn to intersect the 2 mm thick flat heat-sink curve in Section III. From this point a vertical line is drawn downwards to intersect the TO-3 envelope curve in Section IV and moving horizontally to the left will give a heat-sink area of 12 cm². The length/width ratio of the chosen dimensions should not exceed 1.25.

Where the area of a flat heat-sink would be excessive, an extruded heat-sink may be used. When the horizontal line enters Section III and intersects the appropriate heat-sink curve, the line should then be continued vertically upwards to give the length of the extrusion.

An enlarged version of the heat-sink design curves for laboratory use is supplied with this Application Book.

INDEX

Acoustic power	175
Adjustment of protection networks	108, 127
Amplifier	
-, basic voltage	15
-, buffer.	22, 52
-, low distortion	21
-, microphone	24
-, mixer.	26
-, presence	55
Balance control	45
Balance meter	47
Basic voltage amplifier	15
Bass-reflex enclosures	181
Battery	
equipment	66
internal resistance	10
Buffer amplifier	22, 52
Capacitors	
-, output	36
-, use of	57
Complementary output stages	61
Cooling clip	193
Cross-over	
distortion	58, 63
filters.	175
Damping factor	59
Differential input stage	137
DIN Standards for high fidelity.	189
Disc equalization	27
Distortion	
-, cross-over.	58, 63
-, harmonic	9, 58
-, intermodulation	9, 58
-, phase	57
-, power amplifier	57
Dynamic range	57

Earthing	71
Effective loudness	5
Enclosures	
-, bass-reflex	181
-, sealed	182
-, resonance frequency of	183
-, stiffness of	185
Equalization characteristics	
-, disc recordings	27
-, R.I.A.A.	28
-, tape heads	31, 164
Filters	
-, cross-over	175
-, low-pass/high-pass	52
-, noise	53
-, rumble	53
-, scratch	7, 53
-, smoothing	38
Frequency range of musical instruments	8
Frequency response of loudspeakers	186
Gain	
-, playback	167
-, recording	167
-, transistor	10
Harmonic distortion	9, 58
Heat-sink design	192
High fidelity DIN Standards	189
High output voltage amplifier	21
Input resistance calculations	166
Intermodulation distortion	9, 58
Loudness, effective	5
Loudspeaker	
acoustic power	175
distortion	169
enclosures	181
frequency response	186
overloading	175
positioning	180
power handling capacity	179
resonance frequency	182
Low distortion amplifier	21
Low noise	9
Low-pass/high-pass filter	52

Microphone	
amplifier	24
-, sensitivity for	4
Mid-point voltage calculation	94, 102, 121
Mixer with two inputs	26
Monitor	
output	33
tape input	44
Mono power requirements	180
Music power rating	60
Musical instruments, frequency range	8
Noise	
contours	12
filter	53
level	58
-, low.	9
-, thermal	9
Output capacitors	36
Output power ratings	60
Overdrive indicator	133
Overloading	175
Physiological volume control	6
Playback gain	167
Power	
-, acoustic	175
bandwidth	60
handling capacity	179
Power supply	
internal resistance	73
unit	121
Pre-amplifier	
-, magnetic pick-up	27
-, Universal	33
Presence control	
amplifier	55
principle	6
Protection networks, adjustment	108, 127
Quasi-complementary symmetry	65
Quiescent current stabilization	102
Rated output power	60
Recording characteristics	3
Recording gain	167
R.I.A.A. characteristic	3
Rumble filter	53

Scratch filter	7, 53
Sealed enclosures	182
Sensitivity for various inputs	2
Short-circuit conditions	105, 121
Signal input level adjustment	43
Signal-to-noise ratio	9
Sine-wave rating	60
Small-signal transistors	11
Smoothing filter	38
Stereo	
pre-amplifiers	36
power requirements	179
Stabilized supply voltage	60, 121
Stray fields	73
Tape head equalization	31, 164
Tape playback voltage	163
Thermal noise	9
Thermal resistance	192
Tone control	48
Transformers	61
Transients	
-, amplifier	8
-, loudspeaker	169
Transistor	
biasing	10
dissipation	192
gain	10
noise	12
working point	10, 64
Tweeters	169
Volume control, physiological	6
Width control	50
Woofers	169
Worst case dissipation	120, 192

Technology relating to the products described in this book is shared by the following companies.

Argentina

FAPESA I.y.C.
Melincué 2594
Tel. 50-9941/8155
BUENOS AIRES

Australia

Philips Industries Ltd.
Miniwatt Electronics Division
20, Herbert St.
Tel. 43-2171
ARTARMON, N.S.W.

Austria

WIVEG
Prinz Eugenstrasse 32
Tel. 65 16 21
1041 WIEN

Belgium

M.B.L.E.
80, rue des Deux Gares
Tel. 23 00 00
1070 BRUSSELS

Brazil

IBRAPE S.A.
Rua Manoel Ramos Paiva 506
Tel. 93-5141
SAO PAULO

Canada

Philips Electron Devices
116 Vanderhoof Ave.
Tel. 425-5161
TORONTO 17, Ontario

Chile

Philips Chilena S.A.
Av. Santa Maria 0760
Tel. 39 40 01
SANTIAGO

Colombia

SADAPE S.A.
Calle 19, No. 5-51
Tel. 422-175
BOGOTA D.E. 1

Denmark

Miniwatt A/S
Emdrupvej 115A
Tel. (01) 69 16 22
DK-2400 KØBENHAVN NV

Finland

Oy Philips A.B.
Elcoma Division
Kaivokatu 8
Tel. 10 915
HELSINKI 10

France

R.T.C.
La Radiotechnique-Compelec
Avenue Ledru Rollin 130
Tel. 797-99-30
PARIS 11

Germany

VALVO G.m.b.H.
Valvo Haus
Burchardstrasse 19
Tel. (0411) 33 91 31
2 HAMBURG 1

Greece

Philips S.A. Hellénique
Elcoma Division
52, Av. Syngrou
Tel. 915.311
ATHENS

Hong Kong

Philips Hong Kong Ltd.
Components Deps.
St. George's Building 21st Fl.
Tel. K-42 82 05
HONG KONG

India

INBELEC Div. of
Philips India Ltd.
Band Box Building
254-D, Dr. Annie Besant Road
Tel. 45 33 86, 45 64 20, 45 29 86
Worli, BOMBAY 18 (WB)

Indonesia

P.T. Philips-Ralin Electronics
Elcoma Division
Djalan Gadjah Mada 18
Tel. 44 163
DJAKARTA

Ireland

Philips Electrical (Ireland) Pty.
Newstead, Clonskeagh
Tel. 69 33 55
DUBLIN 6

Italy

Philips S.p.A.
Sezione Elcoma
Piazza IV Novembre 3
Tel. 69.94
MILANO

Japan

I.D.C.C. Ltd.
Kokusai Building, 7th floor
Marunouchi
Tel. (213) 6751.7
TOKYO

Mexico

Electrónica S.A. de C.V.
Varsovia No. 36
Tel. 5-33-11-80
MEXICO 6, D.F.

Netherlands

Philips Nederland N.V.
Afd. Elonco
Boschdijk, VB
Tel. (040) 433 33 33
EINDHOVEN

New Zealand

EDAC Ltd.
70-72 Kingsford Smith Street
Tel. 873 159
WELLINGTON

Norway

Electronica A/S
Middelthungsgate 27
Tel. 46 39 70
OSLO 3

Peru

CADESA
Av. Abancay 1176
Ofs. 606-607
Tel. 7 73 17
LIMA

Portugal

Philips Portuguesa S.A.R.L.
Rua Joaquim Antonio de
Aguar 66
Tel. 68 37 21/9
LISBOA

South Africa

EDAC (Pty) Ltd.
South Park Lane
New Doornfontein
Tel. 24/6701-2
JOHANNESBURG

Spain

COPRESA S.A.
Balmes 22
Tel. 2 32 03 00
BARCELONA 7

Sweden

ELCOMA A.B.
Lidingövägen 50
Tel. 08/67 97 80
10250 STOCKHOLM 27

Switzerland

Philips A.G.
Edenstrasse 20
Tel. 051/44 22 11
CH-8027 ZUERICH

Taiwan

Philips Taiwan Ltd.
Plastic Building, 10th Fl.
No. 1, section 2, Nanking East Rd.
Tel. 55 97 42
TAIPEI

Turkey

Türk Philips Ticaret A.S.
EMET Department
Gümüşsuyu Cad.78-80
Tel. 45.32.50
Beyoğlu, İSTANBUL

United Kingdom
Mullard Ltd.
Mullard House
Torrington Place
Tel. 01-580 6633
LONDON W.C. 1

United States
Amperex Electronic Corp.

Electron Tubes Div.
Tel. 516 WE 1-6200
HICKSVILLE N.Y.

Sem. and Microcircuits Div.
Tel. 401-762-9000
SLATERSVILLE R.I. 02876

Electronic Components Div.
Tel. 516-234-7000
HAUPTPAGE N.Y.

Uruguay
Luzilectron S.A.
Rondeau 1567, piso 5
Tel. 9 43 21
MONTEVIDEO

Venezuela
C.A. Philips Venezolana
Elcoma Department
Colinas de Bello Monte
Tel. 72.01.51
CARACAS

