

INSTRUMENT CATHODE-RAY TUBE

- 14 cm diagonal rectangular flat face
- domed mesh post-deflection acceleration
- internal magnetic lens system for correction of orthogonality, astigmatism and eccentricity
- quick-heating cathode
- side contacts to deflection plates
- internal graticule
- high sensitivity and high brightness
- short overall length
- for compact oscilloscopes with up to 150 MHz bandwidth

QUICK REFERENCE DATA

Final accelerator voltage	$V_{g7(\text{el})}$	16,5 kV
First accelerator voltage	V_{g4}	2,2 kV
Minimum useful scan area		100 mm x 80 mm
Deflection coefficient		
horizontal	M_x	8,3 V/cm
vertical	M_y	4 V/cm (max. 4,2 V/cm)
Photographic writing speed	p.w.s.	2,0 cm/ns

OPTICAL DATA

Screen	metal-backed phosphor
type	GH
colour	green
persistence	medium short
Useful screen area	$\geq 102 \text{ mm} \times 82 \text{ mm}$; note 1 (last page but one)
Useful scan area	$\geq 100 \text{ mm} \times 80 \text{ mm}$
Internal graticule	type 123; see Fig. 5

HEATING

Indirect by a.c. or d.c.*

Heater voltage	V_f	6,3 V
Heater current	I_f	0,24 A
Heating time to attain 10% of the cathode current at equilibrium conditions		approx. 5 s

* Not to be connected in series with other tubes.



MECHANICAL DATA**Dimensions and connections** (see also outline drawings)

Overall length (socket included) ≤ 338 mm
 Faceplate dimensions $118 \pm 0,5$ mm x $98 \pm 0,5$ mm

Net mass approx. 1 kg

Base 12 pin, all glass, JEDEC B12-246

Mounting

The tube can be mounted in any position. It must not be supported by the socket and not by the base region alone. The reference points on adjoining edges of the faceplate (see Fig. 5) enable the tube to be mounted accurately in the front panel, thus providing optimum alignment of the internal graticule.

Accessories

Pin protector (required for shipping) supplied with tube
 Socket with solder tags type 55594
 Socket with printed-wiring pins type 55595
 Side contact connector for ϕ 0,65 mm pin (4 required) type 55596 (AMP87313)
 Final accelerator contact connector type 55569/55597
 Mu-metal shield 55599

FOCUSING

electrostatic

DEFLECTION

x-plates double electrostatic
 y-plates symmetrical
 symmetrical

CAPACITANCES

x ₁ to all other elements except x ₂	C _{x1(x2)}	2,2 pF
x ₂ to all other elements except x ₁	C _{x2(x1)}	2,3 pF
y ₁ to all other elements except y ₂	C _{y1(y2)}	1,7 pF
y ₂ to all other elements except y ₁	C _{y2(y1)}	1,8 pF
x ₁ to x ₂	C _{x1x2}	3 pF
y ₁ to y ₂	C _{y1y2}	1,3 pF
Control grid to all other elements	C _{g1}	6,5 pF
Cathode to all other elements	C _k	3,2 pF
Focusing electrode to all other elements	C _{g3}	8 pF
Final accelerator electrode to all other elements	C _{g7}	480 pF

DIMENSIONS AND CONNECTIONS

Dimensions in mm

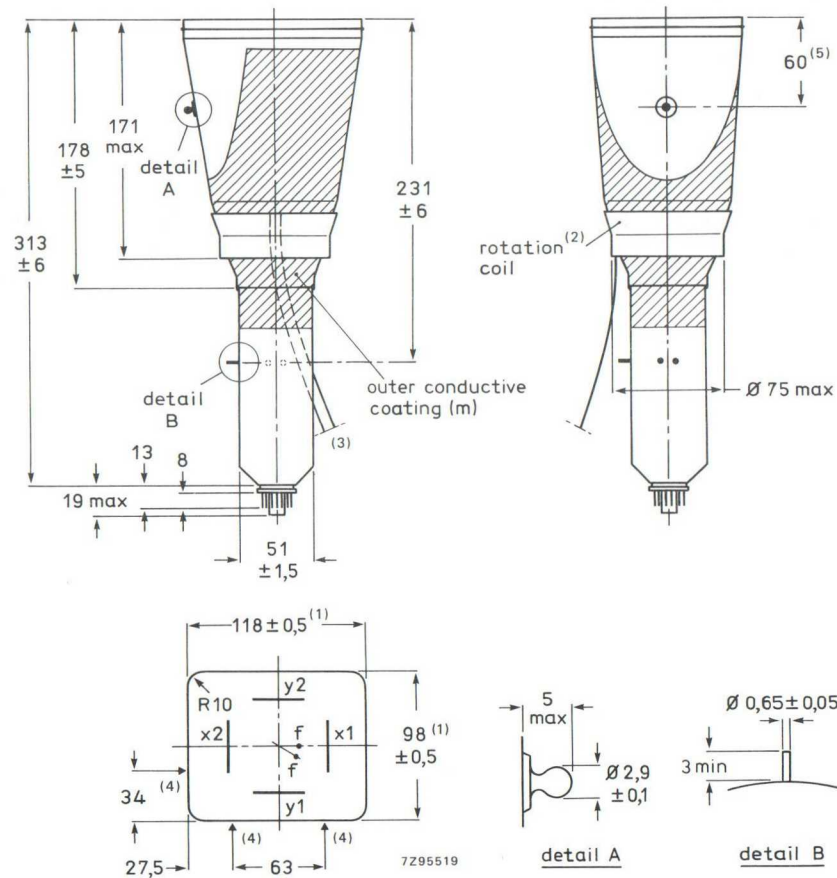

Fig. 1 Outlines.

1. Dimensions of faceplate only. The complete assembly of faceplate and cone (frit seal included) will pass through an opening of 122 x 102 mm (diagonal 153 mm).
2. The coil is fixed to the envelope with resin and adhesive tape.
3. The length of the connecting leads of the rotation coil is min. 350 mm.
4. Reference points on faceplate for graticule alignment (see Fig. 5).
5. The centre of the final accelerator contact is situated within a square of 10 mm x 10 mm around the indicated position.

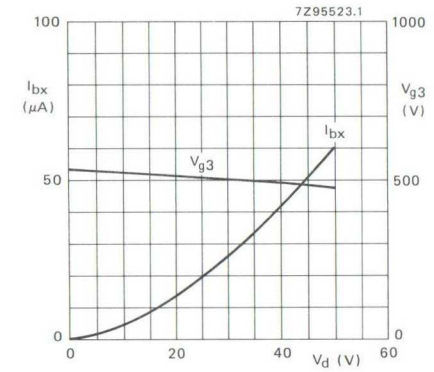

Fig. 6 Beam current (I_{bx}) and focusing voltage (V_{g3}) as a function of grid drive voltage (V_d); typical curves.

I_{bx} is the beam current, without scan, measured on x2, when the deflection plate potentials have been adjusted to $V_{y1} = V_{y2} = 2200$ V, $V_{x1} = 1500$ V, $V_{x2} = 1900$ V, thus directing the total beam current to x2.

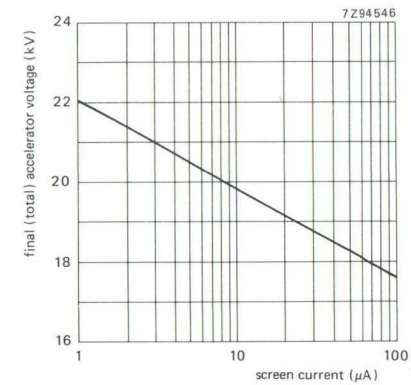

Fig. 7 0,5 mR/h isoexposure-rate limit curve, measured according to TEPAC104.

NOTES

- As the frit seal is visible through the faceplate, and not necessarily aligned with the internal graticule, application of an external passe-partout with open area of max. 102 mm x 82 mm is recommended. The internal graticule is aligned with the faceplate by using the faceplate reference points (see Fig. 5).
- The deflection plates must be operated symmetrically; floating mean x- or y-potentials will result into non-uniform line width and geometry distortion. The mean x- and y-potentials should be equal; under this condition the tube will be within the specification without corrections for astigmatism and geometry. A range of $\Delta V_{g5} = -50$ to $+50$ V may be applied for pincushion/barrel correction. The tube features internal magnetic correction for orthogonality between x- and y-traces, spot shaping (astigmatism) and eccentricity calibration.
- For some applications a mean x-potential up to 50 V positive with respect to mean y-potential is inevitable. In this case V_{g5} must be made equal to mean x-potential, and a range of 0 to -25 V with respect to mean y-potential will be required on g4 for astigmatism correction. The circuit resistance for V_{g4} should be ≤ 10 k Ω .
- The sensitivity at a deflection of less than 75% of the useful scan will not differ from the sensitivity at a deflection of 25% of the useful scan by more than the indicated value.
- A graticule consisting of concentric rectangles of 100 mm x 80 mm and 98 mm x 78 mm is aligned with the internal graticule. With optimum trace rotation correction the edges of a raster will fall between these rectangles.
- The tube has a trace rotation coil, fixed onto the lower cone part. The coil has 1000 turns and a typical resistance of $185 \pm 25 \Omega$ at 20 °C, which increases by approx. 0,4%/K for rising temperature. At typical operation ($V_{g5} = 2200$ V, $V_{g7} = 16,5$ kV) approx. 6,5 mA causes 1° trace rotation. Thus maximum required voltage is approx. 13 V for tube tolerances ($\pm 5^\circ$) and earth magnetic field with reasonable shielding ($\pm 2^\circ$). The required current for 1° trace rotation is related to approx. $\sqrt{V_{g5}}$.
- Measured with the shrinking raster method in the centre of the screen under typical operating conditions, adjusted for optimum spot size at a beam current $I_{\phi} = 10 \mu\text{A}$.

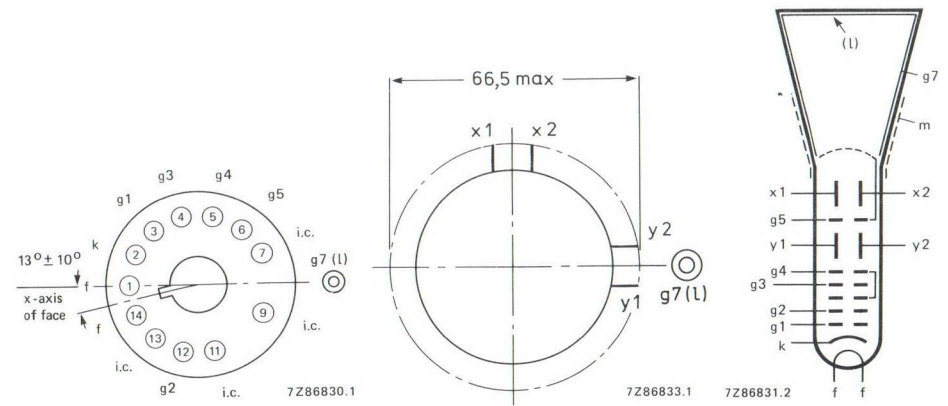

Fig. 2 Pin arrangement; bottom view.

Fig. 3 Side-contact arrangement bottom view.

Fig. 4 Electrode configuration.

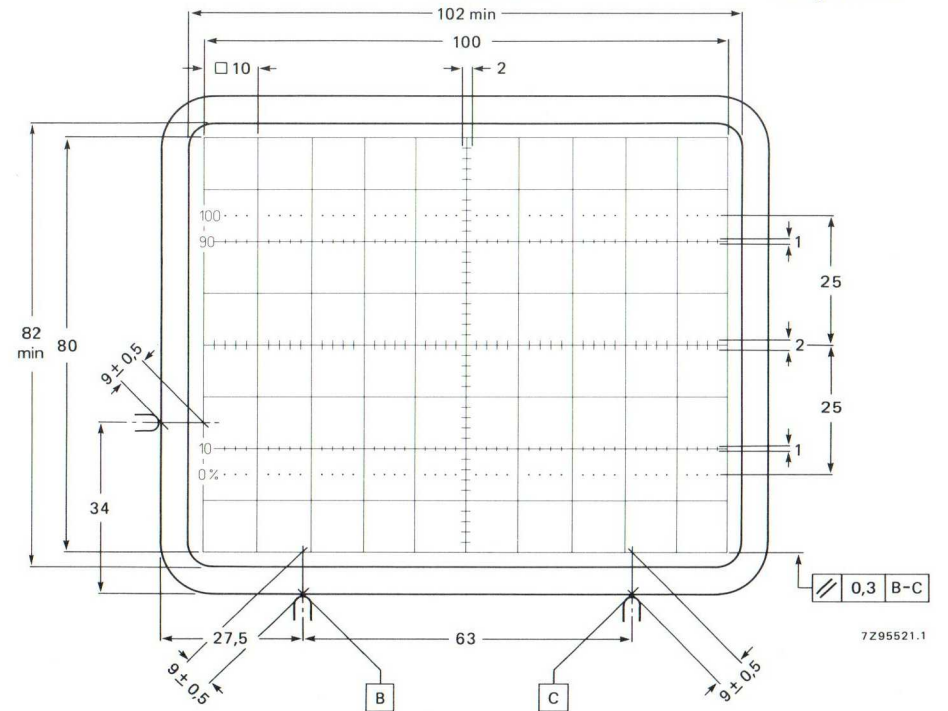

Fig. 5 Front view of tube with internal graticule, type 123. The faceplate reference points are used for aligning the graticule with the faceplate.

Line thickness = 0,2 mm; dot diameter = 0,4 mm; colour: red.