



engineering data service

SYLVANIA

21DQP4

ADVANCE DATA

CHARACTERISTICS

GENERAL DATA

Focusing Method	Electrostatic	
Deflection Method	Magnetic	
Deflection Angles (approx.)		
Horizontal	85	Degrees
Diagonal	90	Degrees
Phosphor	Aluminized P4	
Fluorescence	White	
Persistence	Short to Medium	
Faceplate	Gray Filter Glass	
Light Transmittance (approx.)	74	Percent

ELECTRICAL DATA

Heater Voltage	6.3	Volts
Heater Current	0.6 ± 5%	Ampere
Heater Warm-up Time ¹	11	Seconds
Direct Interelectrode Capacitances (approx.)		
Cathode to All Other Electrodes	5	µf
Grid No. 1 to All Other Electrodes	6	µf
External Conductive Coating to Anode ²	2500	µf Max.
	2000	µf Min.

MECHANICAL DATA

Minimum Useful		
Screen Dimensions	19 1/16 x 15 1/16	Inches
Minimum Useful Screen Area	262	Sq. Inches
Bulb	J171D or J171E	
Bulb Contact (Recessed Small Cavity Cap)	J1-21	
Base		
(Small Shell Duodecal 6-Pin)	B6-63 or B6-203	
Basing	12L	
Weight (approx.)	22 1/2	Pounds

RATINGS

MAXIMUM RATINGS (Absolute Maximum Values)

Anode Voltage	20,000	Volts	dc
Grid No. 4 Voltage			
(Focusing Electrode)	-550 to +1100	Volts	dc
Grid No. 2 Voltage	550	Volts	dc
Grid No. 1 Voltage			
Negative Bias Value	155	Volts	dc
Negative Peak Value	220	Volts	
Positive Bias Value	0	Volts	dc
Positive Peak Value	2	Volts	

QUICK REFERENCE DATA

Television Picture Tube
 21" Direct Viewed
 Rectangular Glass Type
 Spherical Faceplate
 Gray Filter Glass
 Electrostatic Focus
 No Ion Trap
 90° Magnetic Deflection
 External Conductive Coat-
 ing
 Aluminized Screen
 5 Inch Neck Length

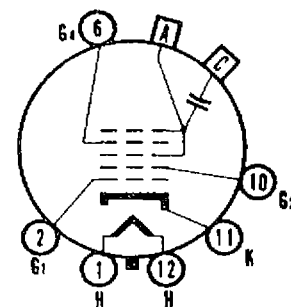
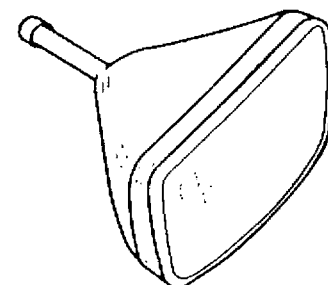

12-1

SYLVANIA ELECTRIC
 PRODUCTS INC.

TELEVISION PICTURE TUBE
 DIVISION

SENECA FALLS, NEW YORK

*Prepared and Released By The
 TECHNICAL PUBLICATIONS SECTION
 EMPORIUM, PENNSYLVANIA*

March 11, 1958

Page 1 of 3

SYLVANIA

21DQP4

Page 2

MAXIMUM RATINGS (Absolute Maximum Values) (Cont'd)

Peak Heater-Cathode Voltage

Heater Negative with Respect to Cathode

During Warm-up Period Not to Exceed

15 Seconds

450 Volts

After Equipment Warm-up Period

200 Volts

Heater Positive with Respect to Cathode

200 Volts

TYPICAL OPERATING CONDITIONS

Anode Voltage

16,000 Volts dc

Grid No. 4 Voltage

-50 to +350 Volts dc

Grid No. 2 Voltage

300 Volts dc

Grid No. 1 Voltage Required for Cutoff³

-35 to -72 Volts dc

CIRCUIT VALUES

Grid No. 1 Circuit Resistance

1.5 Megohms Max.

NOTES:

1. Heater warm-up time is the time required for the voltage across the heater terminals to increase to 5.0 volts in the JETEC test circuit, with $E = 25$ volts and series $R = 31.5$ ohms.
2. External conductive coating must be grounded.
3. Visual extinction of focused raster. Extinction of stationary focused spot will require that these values be about 5 volts more negative.

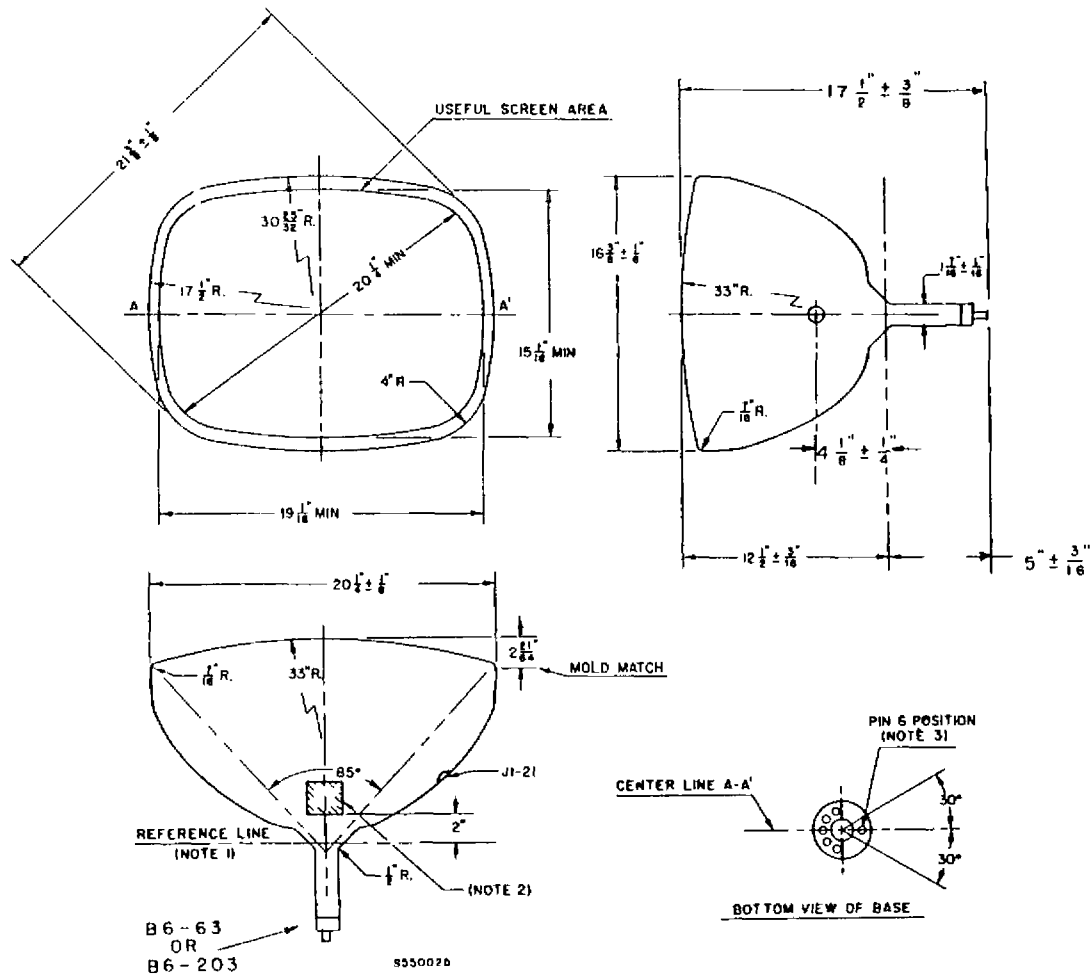

DIAGRAM NOTES:

1. Reference line is determined by the plane C-C' of JETEC No. 116 reference line gauge when the gauge is seated against the glass cone.
2. Contact area for external conductive coating, 2" X 2", located 90° counterclockwise from anode contact as viewed from base end of tube.
3. Pin position No. 6 aligns with horizontal centerline within 30° and is on same side as anode contact (J1-21).

WARNING:

X-ray radiation shielding may be necessary to protect against possible danger of personal injury from prolonged exposure at close range if this tube is operated at higher than the manufacturer's Maximum Rated Anode Voltage or 16,000 volts, whichever is less.