

**ADVANCE DATA**

**CHARACTERISTICS**

**GENERAL DATA**

Focusing Method	Electrostatic	
Deflection Method	Magnetic	
Deflection Angles (approx.)		
Horizontal	105	Degrees
Diagonal	110	Degrees
Vertical	87	Degrees
Phosphor	Aluminized P4	
Fluorescence	White	
Persistence	Short to Medium	
Faceplate	Gray Filter Glass	
Light Transmittance (approx.)	76	Percent

**ELECTRICAL DATA**

Heater Voltage	6.3	Volts
Heater Current	0.30 ±5%	Ampere
Heater Warm-up Time 1	11	Seconds
Direct Interelectrode Capacitances (approx.)		
Cathode to All Other Electrodes	5	µuf
Grid No. 1 to All Other Electrodes	6	µuf
External Conductive Coating to Anode 2	2500	µuf Max.
	1700	µuf Min.

**MECHANICAL DATA**

Minimum Useful Screen Dimensions (Maximum Assured)	19 1/16 x 15 1/16	Inches
Minimum Useful Screen Area	262	Sq. Inches
Bulb Contact (Recessed Small Cavity Cap)	J1-21	
Bulb	J171-G1 or equivalent	
Base	B7-183	
Basing	8HR	
Weight (approx.)	20	Pounds

**RATINGS**

**MAXIMUM RATINGS (Absolute Maximum Values)**

Anode Voltage	19,800	Volts	dc
Grid No. 4 Voltage (Focusing Electrode)	-550 to +1100	Volts	dc
Grid No. 2 Voltage	550	Volts	dc
Grid No. 1 Voltage			
Negative Bias Value	154	Volts	dc
Negative Peak Value	220	Volts	
Positive Bias Value	0	Volts	dc
Positive Peak Value	2	Volts	

**QUICK REFERENCE DATA**

Television Picture Tube  
 21" Direct Viewed  
 Rectangular Glass Type  
 Lightweight Tube  
 Spherical Faceplate  
 Gray Filter Glass  
 Aluminized Screen  
 Electrostatic Focus  
 110° Magnetic Deflection  
 1 1/8" Neck Diameter  
 No Ion Trap  
 External Conductive Coating  
 6.3 Volt, 300 Ma Heater

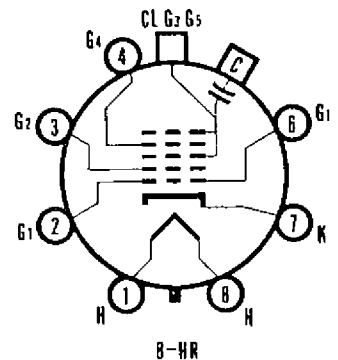
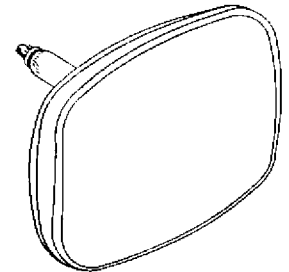

**SYLVANIA ELECTRIC  
 PRODUCTS INC.**  
 TELEVISION PICTURE TUBE  
 DIVISION  
 SENECA FALLS, NEW YORK

*Prepared and Released By The  
 TECHNICAL PUBLICATIONS SECTION  
 EMPORIUM, PENNSYLVANIA*

March 17, 1958

SYLVANIA

21DKP4

Page 2

MAXIMUM RATINGS (Absolute Maximum Values) (Cont'd.)

Peak Heater-Cathode Voltage	
Heater Negative with Respect to Cathode	
During Warm-up Period not to Exceed 15 Seconds	450 Volts
After Equipment Warm-up Period	200 Volts
Heater Positive with Respect to Cathode	200 Volts

TYPICAL OPERATING CONDITIONS

Anode Voltage	16,000 Volts dc
Grid No. 4 Voltage for Focus	0 to 400 Volts dc
Grid No. 2 Voltage	300 Volts dc
Grid No. 1 Voltage Required for Cutoff <sup>3</sup>	-35 to -72 Volts dc

CIRCUIT VALUES

Grid No. 1 Circuit Resistance	1.5 Megohms Max.
-------------------------------	------------------

NOTES:

1. Heater warm-up time is defined as the time required for the voltage across the heater to reach 80% of its rated value after applying four (4) times rated heater voltage to a circuit consisting of the tube heater in series with a resistance equal to three (3) times rated heater voltage divided by rated heater current.
2. External conductive coating must be grounded.
3. Visual extinction of focused raster. Extinction of stationary focused spot will require that these values be about 5 volts more negative.

WARNING:

X-ray radiation shielding may be necessary to protect against possible danger of personal injury from prolonged exposure at close range if this tube is operated at higher than the manufacturer's Maximum Rated Anode Voltage or 16,000 volts, whichever is less.

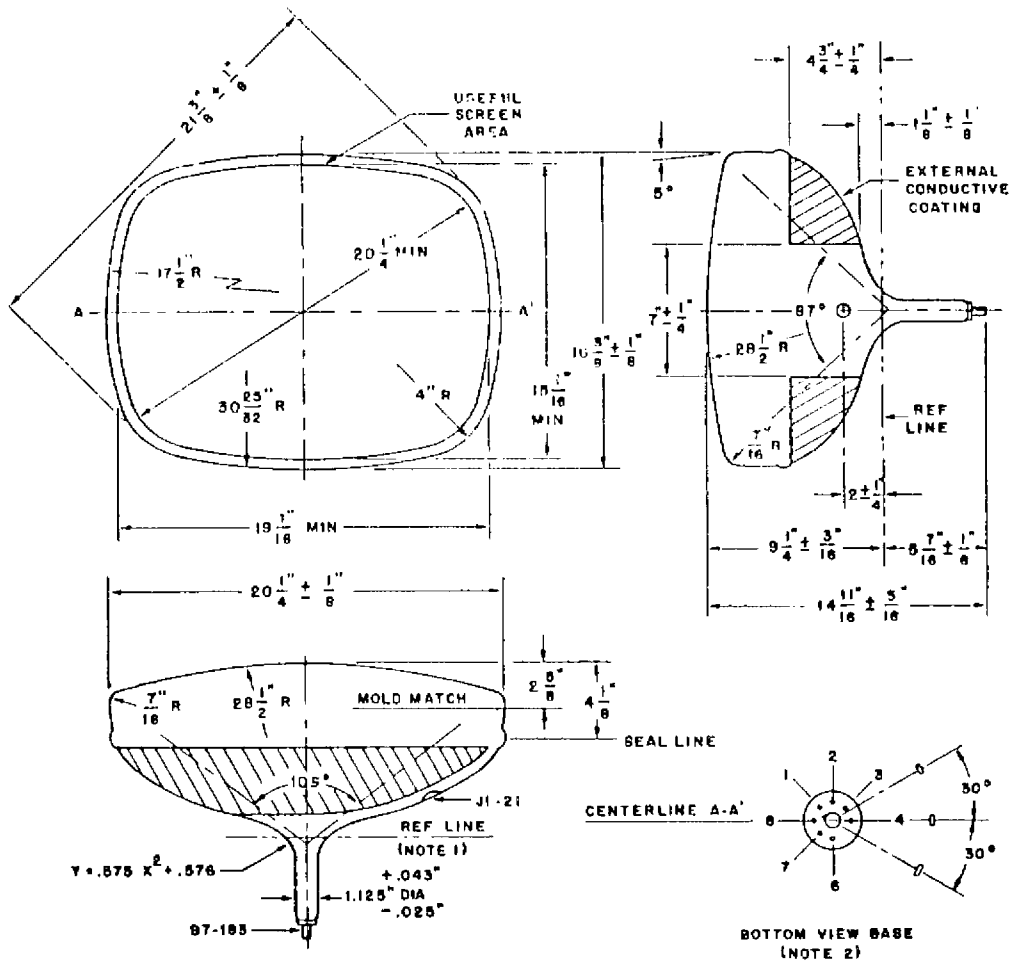

DIAGRAM NOTES:

1. Reference line is determined by plane C-C' of JETEC No. 126 Reference Line gauge when the gauge is seated against the bulb.
2. Base Pin No. 4 aligns with anode contact (J1-21) within 30°.