

VIBRATING CAPACITOR

Vibrating membrane capacitor in evacuated envelope to be driven by a high-frequency electric field.

Application: D.C. to A.C. converter, e.g. in dosimeters, pH meters and electrometer equipment, where a very high input resistance is of paramount importance.

Equipment measuring currents of 500 electrons per second have been realised.

QUICK REFERENCE DATA

Contact potential	-50 to +50 mV
Short term drift of contact potential	< 100 μ V
Insulation	> 10 ¹⁵ Ω
Outline dimensions:	
overall length	max. 64.7 mm
diameter	max. 30.2 mm

MECHANICAL DATA

Base: Magnoval, gold plated pins

C_m = measuring capacitor

C_{dr} = driving capacitor

Operating position: any

Dimensions in mm

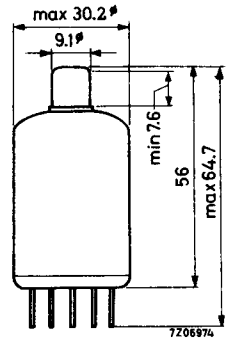
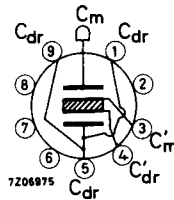

PRINCIPLE OF OPERATION

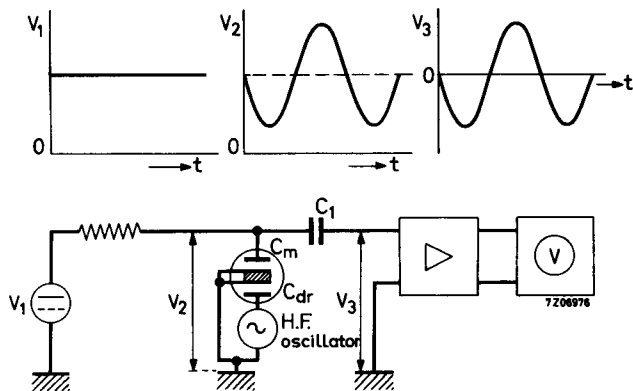

The D.C. voltage to be measured is connected to capacitor C_m . The earthed membrane vibrates in its own resonance frequency as a result of an H.F. electrical field between the electrodes of capacitor C_{dr} . So the D.C. voltage on capacitor C_m is modulated in the resonance frequency of the membrane. Capacitor C_1 insulates the D.C. source from the A.C. amplifier.

LIMITING VALUES (Absolute max. rating system)

D.C. voltage on C_m	max. 25 V
Conversion efficiency	
$\frac{\text{R.M.S. output voltage}}{\text{D.C. input voltage}}$	max. 40 % ¹⁾

ELECTRICAL DATA

Contact potential over C_m	-50 to +50 mV
Short term drift (within 1 day)	0.1 mV
Long term drift (within 1 month)	1 mV
Temperature dependence	20 $\mu\text{V}/^\circ\text{C}$

Conversion efficiency:

At a certain driving voltage the conversion efficiency will show a max. spread of $\pm 60\%$ (1 : 4)

¹⁾ Above 40 % it is possible that two capacitor plates will touch each other and will be damaged.

ELECTRICAL DATA (continued)

Driving voltage:

There can always be found a value of the H.F. driving voltage at which all capacitors have a conversion efficiency between 10% and 40%. ¹⁾

Insulation resistance between any two capacitor terminals	> 10 ¹⁵ Ω ²⁾
Resonance frequency of the membrane	5.3 to 6.3 kHz
Drift	1.5 %
Temperature dependance	± 1 Hz/°C
Capacitances of C _m and C _{dr}	35 pF
Temperature dependance between -10 and +60 °C	ΔC 1 pF

SHOCK AND VIBRATION RESISTANCE

The following test conditions are applied to assess the mechanical quality of the tube. These conditions are not intended to be used as normal operating conditions.

Shock

The tube is subjected 5 times in each of 4 positions to an acceleration of 500 g supplied by an NRL shock machine with the hammer lifted over an angle of 30°.

Vibration

The tube is subjected to a vibration of 15 to 1500 Hz with an acceleration of 2.5 g.

APPLICATION NOTES

The capacitive drive opens the possibility to use as driving signal for the membrane a high frequency signal amplitude-modulated with the resonance frequency of the vibrating membrane.

Since in that case there is a great difference between the frequency of the driving signal and the modulation frequency of the voltage to be measured, the stray influences of the driving signal can easily be kept away from the measuring amplifier. In addition, a high frequency drive simplifies design and execution of the driving oscillator.

- 1) For instance in an apparatus realised with the circuit shown in Fig.2, it turned out that all capacitors have a conversion efficiency between 10 and 40% at a voltage over L₁ of 1 V_{RMS}.
- 2) Under standard atmospheric conditions as defined in I.E.C. publication 68-1, i.e. any combination of temperature, humidity and pressure within the following limits:

Temperature	+15 to +35 °C
Relative humidity	45 to 75 %
Air pressure	860 to 1060 mbar

EXAMPLE OF A DRIVING OSCILLATOR

Operating principle

Fig. 1

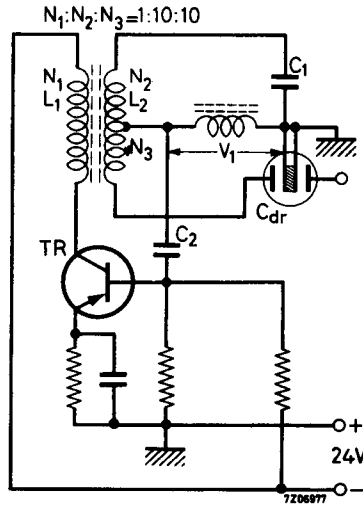

The driving capacitor (C_{dr}) is incorporated in an impedance bridge that determines the feedback to the amplifier transistor. Capacitance C_1 has been given a slightly larger value than that of capacitor C_{dr} in its quiescent state. Due to this the fed-back A.C. voltage V_1 has the proper phase and amplitude to cause the circuit to oscillate in a frequency that is mainly determined by the circuit $L_2 C_1 C_{dr}$.

The electric attractive force between the capacitor plates of C_{dr} makes the membrane move towards the fixed plate of C_{dr} as a result of which its capacitance increases, the transistor receives less feedback and the oscillator voltage decreases.

The phases and amplitudes of the electrical and the mechanical forces on the membrane and of the feedback factor are such that the membrane begins to vibrate in its resonance frequency, while the H.F. voltage is modulated in amplitude with this frequency.

Since it is very difficult to realize this circuit in such a way that a stable operation is ensured, it is advisable to add some components for automatical adjustment of the capacitance C_1 .

See the following circuit.

EXAMPLE OF A DRIVING OSCILLATOR (continued)

Practical circuit

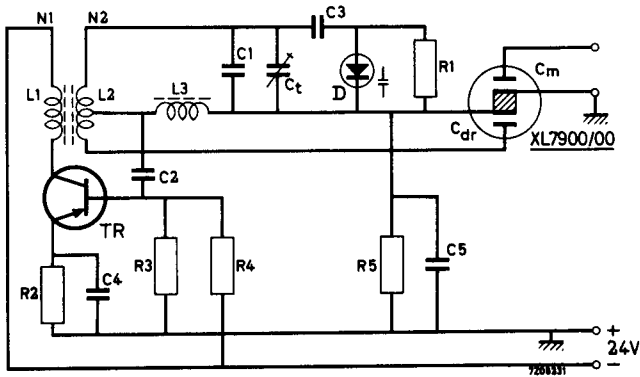

Fig.2

- | | | |
|---------------------------------|-----------------------------|-----------------------------------|
| $C_1 = 12 \text{ pF mica}$ | $R_1 = 68 \text{ k}\Omega$ | $L_2 = 1.3 \text{ mH}$ |
| $C_2 = 1500 \text{ pF}$ | $R_2 = 3.3 \text{ k}\Omega$ | $L_3 = 1.3 \text{ mH R.F. choke}$ |
| $C_3 = 10 \text{ pF mica}$ | $R_3 = 4.7 \text{ k}\Omega$ | $N_2/N_1 = 20$ |
| $C_4 = 2200 \text{ pF}$ | $R_4 = 1 \text{ k}\Omega$ | $TR = \text{BCY70}$ |
| $C_5 = 0.1 \text{ }\mu\text{F}$ | $R_5 = 1 \text{ M}\Omega$ | $D = \text{BA102}$ |
| $C_t = 25 \text{ pF max.}$ | | |

PHILIPS

Data handbook



Electronic
components
and materials

XL7900

page	sheet	date
1	1	1968.12
2	2	1968.12
3	3	1968.12
4	4	1968.12
5	5	1970.01
6	FP	2001.05.18