

Design and Application

Forced-air cooled high-power traveling-wave tube for the frequency range 470 to 860 MHz with an average gain of 30 dB.

The tube is intended for use in Band IV/V UHF TV transmitters and translators, FM sound transmitters and microwave radio amplifiers. It is focused by a permanent magnet, and is replaceable within this magnet system.

The tube is designed for use with coaxial input and output circuits.

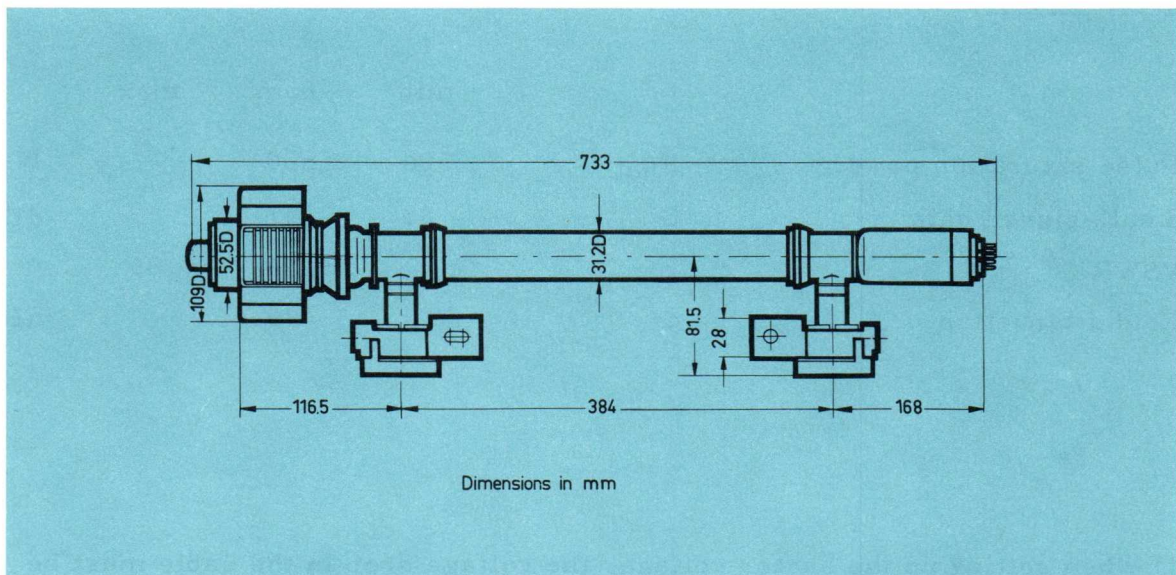

| | |
|------------------------------|---|
| Base: | special 8-pin type ¹⁾ |
| Weight of tube: | 3 kp (6.6 lbs) |
| Weight of magnet system: | 40 kp (88 lbs) |
| Dimensions of magnet system: | approx. 200 x 220 x 750 mm (8" x 8.5" x 29 1/2") |
| r. f. connector: | coaxial connection, 50 or 60 Ω (various standardized connections, see page 9) |
| Mounting position: | in fixed equipment, optional when mounted vertically, the best position with respect to cooling is with the collector uppermost |

¹⁾ The socket with cable is supplied as an accessory (see page 9)

| |
|---------|
| Heating |
|---------|

| | | | |
|----------------|-------|---------------|--------|
| Heater voltage | E_f | 6.3 | Vac 1) |
| Heater current | I_f | ≈ 2.6 | Aac |

indirect by ac, parallel supply
Metal capillary dispenser cathode

| |
|-----------------|
| Characteristics |
|-----------------|

(F = 700 MHz, $I_k = 750$ mA)

| | | min | nom | max | |
|------------------------|-----------|-----|------|------|------|
| Pulse saturation power | P_{sat} | 500 | 600 | | W 2) |
| Small-signal gain | G | 33 | 37 | | dB |
| VSWR | | | 1.35 | 1.85 | 3) |
| Cold attenuation | α | | 70 | | dB |

1) When setting up the heater voltage, the voltage drop in the cable must be taken into account. This is 0.25 V in the standard cable 1.2 m long supplied with the magnet.

If the heater voltage variation exceeds the admissible 2 % of the setting value (absolute limits) the operational performance and life of the tube will be impaired. For standby operation, the heater voltage must be reduced to 5.6 V; the tube is then fully operational when the heater voltage is increased to its nominal value and the electrode voltages and r. f. drive applied simultaneously.

2) The saturation power may only be measured in pulsed operation.

3) Cold match at the tube input and output over the frequency band 470 to 860 MHz.

| Maximum Ratings | (absolute values) | | | |
|---|-------------------|-----|---------|---------------------------|
| Collector voltage | E_b | max | 3300 | Vdc ¹⁾ |
| Collector voltage at zero collector current | E_{bo} | max | 4000 | Vdc |
| Collector dissipation | P_p | max | 2600 | W |
| Helix voltage | E_h | max | 3500 | Vdc |
| Helix voltage at zero helix current | E_{ho} | max | 4000 | Vdc |
| Helix current | I_h | max | 30 | mAdc ²⁾ |
| Grid No. 2 voltage | E_{c2} | max | 1000 | Vdc |
| Grid No. 2 current | I_{c2} | max | ± 3 | mAdc |
| Grid No. 1 voltage negative | E_{c1} | min | - 200 | Vdc |
| Grid No. 1 voltage positive | $+E_{c1}$ | max | 0 | Vdc |
| Cathode current | I_k | max | 750 | mAdc |
| Reflected CW power | | max | 20 | W |
| Collector temperature | T | max | 200 | $^{\circ}C$ |
| Magnet system temperature | T | max | 55 | $^{\circ}C$ ³⁾ |
| Ambient temperature | T_A | min | - 20 | $^{\circ}C$ |
| Storage temperature for tube and magnet | T_A | min | - 50 | $^{\circ}C$ |

Typical Operation (for characteristics see page K 1)

The collector, helix and grid No. 1 voltages and the cathode current are fixed values for each frequency, and remain unchanged when the tube is replaced. The helix voltage must be set up depending on the operating frequency (see pages K 2 and K 5), and the collector voltage must always be 200 V below the helix voltage.

| TV band | | IV | V | |
|---|-----------------|-----------------------|-----------------------|-------------------|
| Video carrier frequency | F_v | 550 | 700 | MHz |
| Sync power output | P_{syn} | 170 | 210 | W |
| Gain | G | 32 | 33 | dB |
| Collector voltage | E_b | 3000 | 2900 | Vdc |
| Helix voltage | E_h | 3200 | 3100 | Vdc |
| Grid No. 2 voltage | E_{c2} | $\approx 550 \pm 200$ | $\approx 600 \pm 200$ | Vdc ⁴⁾ |
| Grid No. 1 voltage | E_{c1} | - 100 | - 100 | Vdc ⁵⁾ |
| Helix current | I_h | 6 | 6 | mAdc |
| Grid No. 2 current | I_{c2} | $\leq \pm 0.5$ | $\leq \pm 0.5$ | mAdc |
| Cathode current | I_k | 700 | 700 | mAdc |
| Linearity (10 to 65 % peak amplitude) | | ≥ 0.95 | ≥ 0.95 | |
| Differential phase of the color sub-carrier | $\Delta\varphi$ | ≤ 3 | ≤ 3 | degrees |
| Gain variation within the channel | | $\leq \pm 0.5$ | $\leq \pm 0.5$ | dB |

- 1) The collector voltage must be 200 V lower than the helix voltage
- 2) Switch-off level of the helix current overload relay (see "Operating Instruction", page 5)
- 3) Measured with a thermocouple at the periphery at the two outer and one of the center cooling fins on the outlet side (see cooling page 6).
- 4) The tolerances apply for designing the power supply
- 5) It is recommended to obtain the grid No. 1 voltage from a cathode resistor

| Maximum Ratings | | (absolute values) | | | |
|---|----------|-------------------|-------|------|----|
| Collector voltage | E_b | max | 3300 | Vdc | 1) |
| Collector voltage at zero collector current | E_{bo} | max | 4000 | Vdc | |
| Collector dissipation | P_p | max | 2600 | W | |
| Helix voltage | E_h | max | 3500 | Vdc | |
| Helix voltage at zero helix current | E_{ho} | max | 4000 | Vdc | |
| Helix current | I_h | max | 20 | mAdc | 2) |
| Grid No. 2 voltage | E_{c2} | max | 1000 | Vdc | |
| Grid No. 1 voltage negative | E_{c1} | min | - 200 | Vdc | |
| Grid No. 1 voltage positive | E_{c1} | max | 0 | Vdc | |
| Cathode current | I_k | max | 800 | mAdc | |
| Reflected CW power | | max | 20 | W | |
| Collector temperature | T | max | 200 | °C | |
| Magnet system temperature | T | max | 55 | °C | 3) |
| Ambient temperature | T_A | min | - 20 | °C | |
| Storage temperature of tube and magnet | T_S | min | - 50 | °C | |

| Typical Operation | | (for characteristics see page K 2 to K 5) | | | |
|-------------------|--|---|--|--|--|
|-------------------|--|---|--|--|--|

The collector, helix and grid No. 1 voltages and the cathode current are fixed values for each frequency, and remain unchanged when the tube is replaced. The helix voltage must be set up depending on the operating frequency (see pages K 2 and K5), and the collector voltage must always be 200 V below the helix voltage.

| | | | | | |
|------------------------------|-----------|---------------|---------------|------|------|
| Video carrier frequency | F | 700 | 700 | MHz | |
| Synchron power output | P_{syn} | 50 | 100 | W | 4) |
| 3 tone intermodulation ratio | IM_3 | > 51 | > 55 | dB | 5)6) |
| Gain | G | 35 | 34.5 | dB | |
| Collector voltage | E_b | 2900 | 2950 | Vdc | |
| Helix voltage | E_h | 3100 | 3150 | Vdc | |
| Grid No. 2 voltage | E_{c2} | 700 ± 200 | 700 ± 200 | Vdc | 7) |
| Grid No. 1 voltage | E_{c1} | - 100 | - 100 | Vdc | 8) |
| Helix current | I_h | ≈ 6 | ≈ 8 | mAdc | |
| Grid No. 2 current | I_{c2} | $< \pm 0.5$ | $< \pm 0.5$ | mAdc | |
| Cathode current | I_k | 750 | 750 | mAdc | |

- 1) The collector voltage must always be 200 V lower than the helix voltage
- 2) Switch-off level of helix current overload relay (see "Operating Instructions" page 5)
- 3) Measured with a thermocouple at the periphery of the two outer and one of the center cooling fins on the outlet side. (see "Cooling" page 6)
- 4) With phase compensator PK 200 (see accessories page 9)
- 5) Measured in accordance with German ARD specification 5/6 (3 tone test). The intermodulation products of the driver stage are not included in these values.
- 6) Video to audio carrier ratio 5!
- 7) The tolerances apply for designing the power supply
- 8) It is recommended to obtain the grid No. 1 voltage from a cathode resistor.

Operating Instructions

Installation

The traveling-wave tube YH 1020 can only be operated in conjunction with its appropriate magnet system MYH 1020. This magnet has a low stray field and is practically insensitive to temperature. When mounting the magnet system the distance between the magnet system and large ferromagnetic parts (e. g. mounting supports) should be 60 mm (2.4") and between the magnet system and small ferromagnetic parts (e. g. screws) 30 mm (1.2"). Between two magnet systems the distance must be at least 90 mm (3.6"). The tube can be replaced by opening out the magnet system along its axis of symmetry.

Power Supply

All voltages applied to the tube are referred to the cathode. The grid No. 2 (E_{c2}), helix (E_h) and collector (E_b) voltages are taken from a single power supply unit (if this is not the case the manufacturer should be consulted.) The helix voltage should be variable between 2900 and 3500 Vdc, and the grid No. 2 voltage variable between the limits specified in the operating conditions. The grid No. 2 voltage is derived from the potential divider R_1 , the total resistance of which should not exceed 250 k Ω . The collector voltage is lower than the helix voltage by an amount corresponding to the voltage drop across R_2 (see operating data pages 3 and 4). The grid No. 1 voltage is derived from the cathode resistor R_k . The phase pushing factors for the various electrodes are

$$\frac{\Delta\Phi}{\Delta E_{c1}} \approx 0.65 \text{ }^\circ/\text{V}, \quad \frac{\Delta\Phi}{\Delta E_{c2}} \approx 0.35 \text{ }^\circ/\text{V}, \quad \frac{\Delta\Phi}{\Delta E_h} \approx 0.7 \text{ }^\circ/\text{V}$$

The power pushing factors are:

$$\frac{\Delta P_o}{\Delta E_{c1}} \approx 1 \text{ W/V}; \quad \frac{\Delta P_o}{\Delta E_{c2}} \approx 0.5 \text{ W/V}; \quad \frac{\Delta P_o}{\Delta E_h} \approx 0.3 \text{ W/V}$$

The protection relay in the helix supply should switch off the complete power supply if the helix current exceeds its maximums rated value. An integration network should be incorporated to prevent surges of up to 60 mAssec tripping the relay within the first 2 seconds after switchon. The trip circuit must operate such that the helix voltage is removed from the tube within 50 msec. In the event of a failure or switch-off of longer than 5 minutes the heater voltage should also be switched off or reduced to 5.6 V. In order to protect grid No. 1 and grid No. 2 a series resistance of 10 k Ω must be incorporated in each supply line.

The heater and cathode are at a potential of approximately 3500 Vdc with respect to ground and the heater transformer insulation must therefore be designed accordingly.

In the interests of stable operation particularly over longer periods of time, it is seriously recommended that the cathode current must be kept constant by automatically controlling the grid No. 2 voltage.

For TV translator operation with concurrent video and audio transmission, the dynamic source impedance of the helix voltage supply at video frequencies should be less than 100 Ω , otherwise the variation of helix current in tact with the video signal will produce additional phase modulation of the output signal.

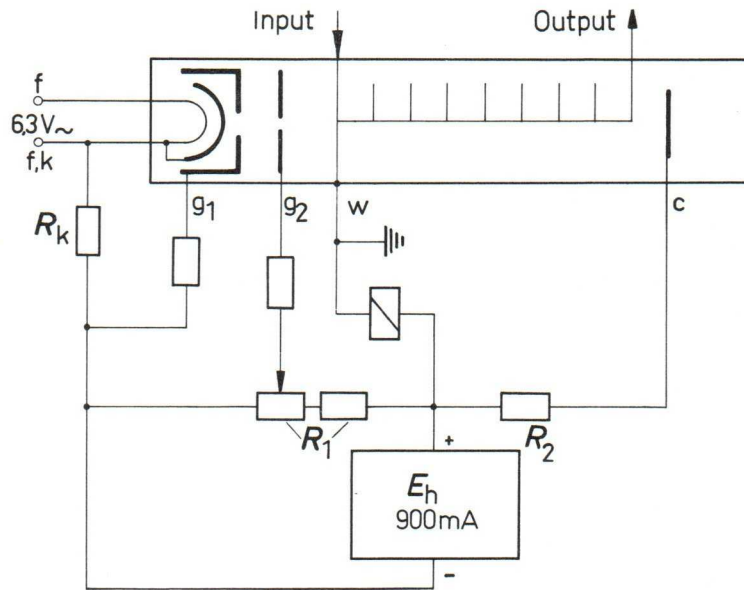

A power supply type YHN 1020 is available for the tube, and contains all the protection circuits (overcurrent etc). Also the YH 1020 can be supplied with power supply, phase compensator, bandpass filter, directional coupler and blower in a rack, designation LVMH 1020, for TV transmitters or translators (data available on request).

Cooling

The required air flow can be obtained from the appropriate graphs on page 10 for sea level and on page 11 for operation at 2500 m (7500 ft). These do not take into account the pressure drop in the air ducting, and depending on their design, the pressure drop quoted in the graph should be multiplied by 1.5 to 2. The magnet system is designed such that the air inlet is on side A (side by which magnet system is mounted) and the outlet on side C. If air flow in the opposite direction is used, the air channelling on both openings should be changed over.

The interlock circuit must include the cooling system such that if the air fails, all voltages including the heater voltage are switched off.

Installation

The magnet system must be properly grounded at the point provided (see page 8).

Insertion of tube into magnet system (full details are contained in the comprehensive assembly instructions).

1. Slide tube into field straightener and screw together. The field straightener is part of the magnet system.
2. Place tube and field straightener in the opened-out magnet system and fasten with screws.
3. Place focusing ring on the field straightener in the middle of the setting marks for field correction (see page 8).
4. Close magnet system.

5. Push socket on to tube base and screw retaining nut to stop (connector socket should not be canted).
6. Fix the coaxial r. f. connectors to the tube input and output ports.

When mounting the magnet system and coaxial r. f. connectors and other connecting cables, any turning or bending moments on the tube input and output should be kept to a minimum.

Connection of supply voltage and setting-up procedure

1. Connect the individual leads (the first time the tube is placed in service): The collector voltage is applied to the tube through the high-voltage cable attached to the magnet system. The helix voltage lead is connected to the earthing plug socket on the earthing plug socket on the magnet system (see page 8). The remaining electrode voltages are applied to the tube via the supply cable screwed to the base of the tube. The individual leads in this cable are color-coded as follows:

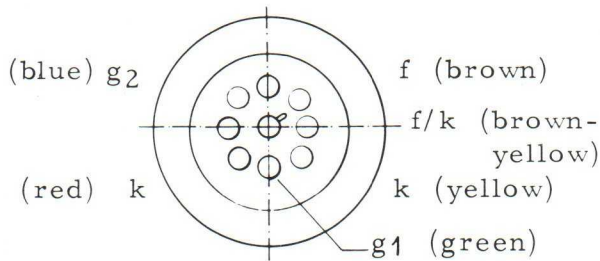

| | | |
|----------------|-----|-------------------------------|
| heater | : | brown |
| heater/cathode | f/k | : brown-yellow ¹⁾ |
| cathode | k | : yellow, red ¹⁾²⁾ |
| grid No. 1 | g1 | : green |
| grid No. 2 | g2 | : blue |
| ground | : | black |

2. Switch on air cooling (see also instructions under "cooling").
3. Switch on all operating voltages, including heater voltage, simultaneously (see "Typical Operation" pages 3 and 4, and corresponding characteristics).
4. Adjust cathode current by varying grid No. 2 voltage.
5. Adjust helix current to minimum with the aid of axial field correction ring (large ring on the connector socket and of the magnet system).
6. Apply r. f. signal to input and repeat field correction as under 5.

- 1) The cathode is internally connected to heater. To avoid heater hum, leads should be connected up exactly as indicated.
- 2) Join the red and yellow leads.

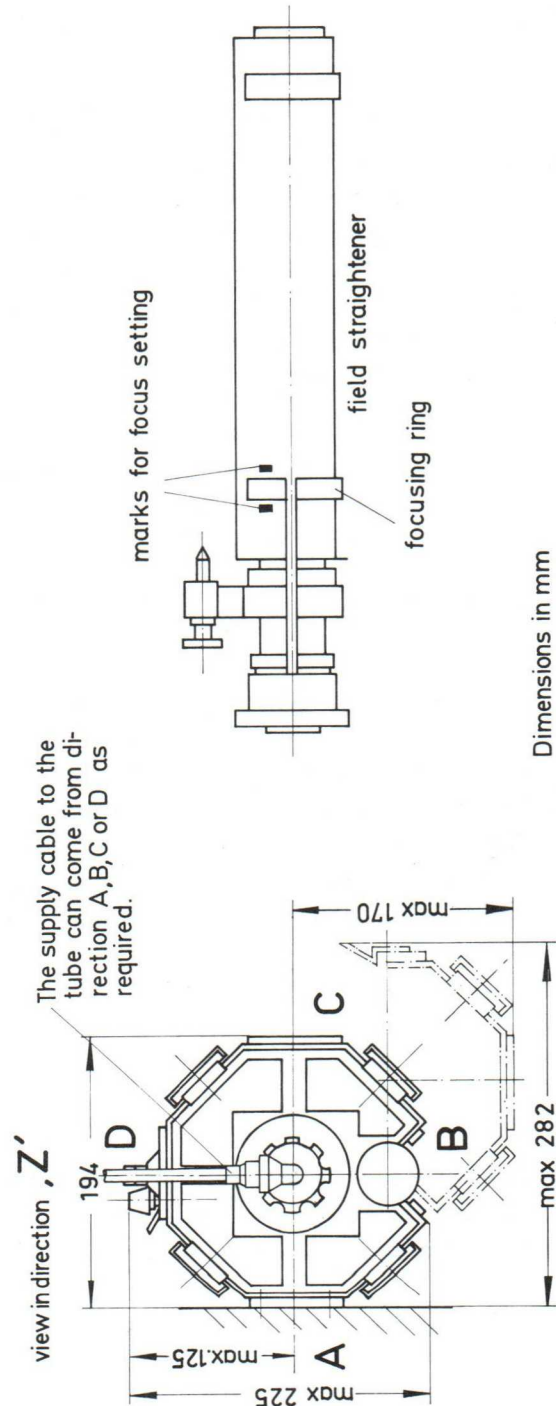
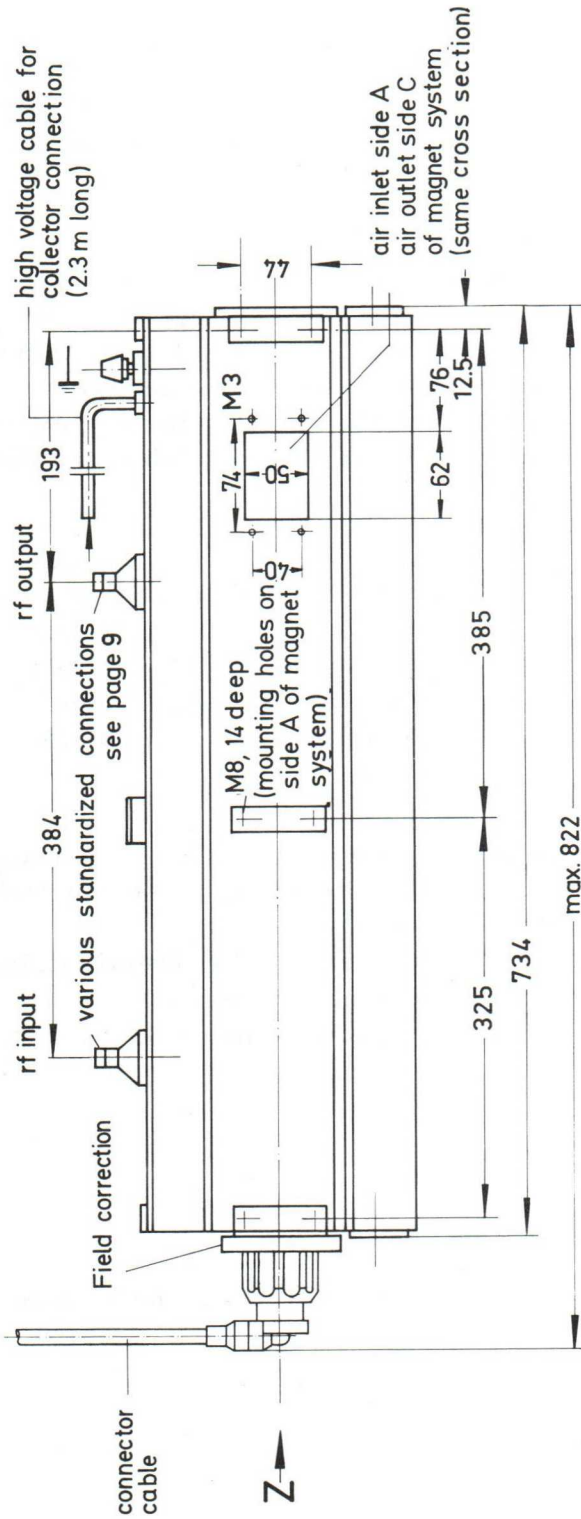

Dimensions in mm

| Designation | Design | Order Number | Fig. |
|--|---|--|--------|
| Traveling wave tube YH 1020 | | Q41-X4652 | |
| Magn. syst. MYH 1020 a | | Q43-X2391 | page 8 |
| Coax. connector Coax. connector Coax. connector Coax. connector Coax. connector Coax. connector Coax. connector Coax. cable M6/16 L50 | 1) 60 Ω , 3.5/9.5 60 Ω , 6/16 50 Ω , 4.1/9.5 50 Ω , 7/16 N-Connector C-Connector BNC-Connector 60 Ω , 6/16; length 0,5 m | Q81-X2401 Q81-X2402 Q81-X2403 Q81-X2404 Q81-X2405 Q81-X2406 Q81-X2407 Q81-X2311 | |
| Connector socket | bend in direction A standard cable length 1.2 m ²⁾⁴⁾ | Q81-X2322 | page 8 |
| Connector socket | bend in direction A cable length as required ³⁾⁴⁾ | Q81-X2316 | page 8 |
| Power supply YHN 1020 | | S65280-Z1020-A2 | |
| Complete rack LVYH 1020 | | S65392-J1020-A1 | |
| Phase compensator PK 200 | for Band IV V | S65107-D200-A1 | |

- 1) Rf connectors should be specified when ordered, and can be used again when the tube is replaced
- 2) 0.1 m of this length as free leads
- 3) when ordering please specify total length of cable and length of free leads
- 4) The cable can also be supplied with a socket heaving a 90° bend in directions B, C or D.

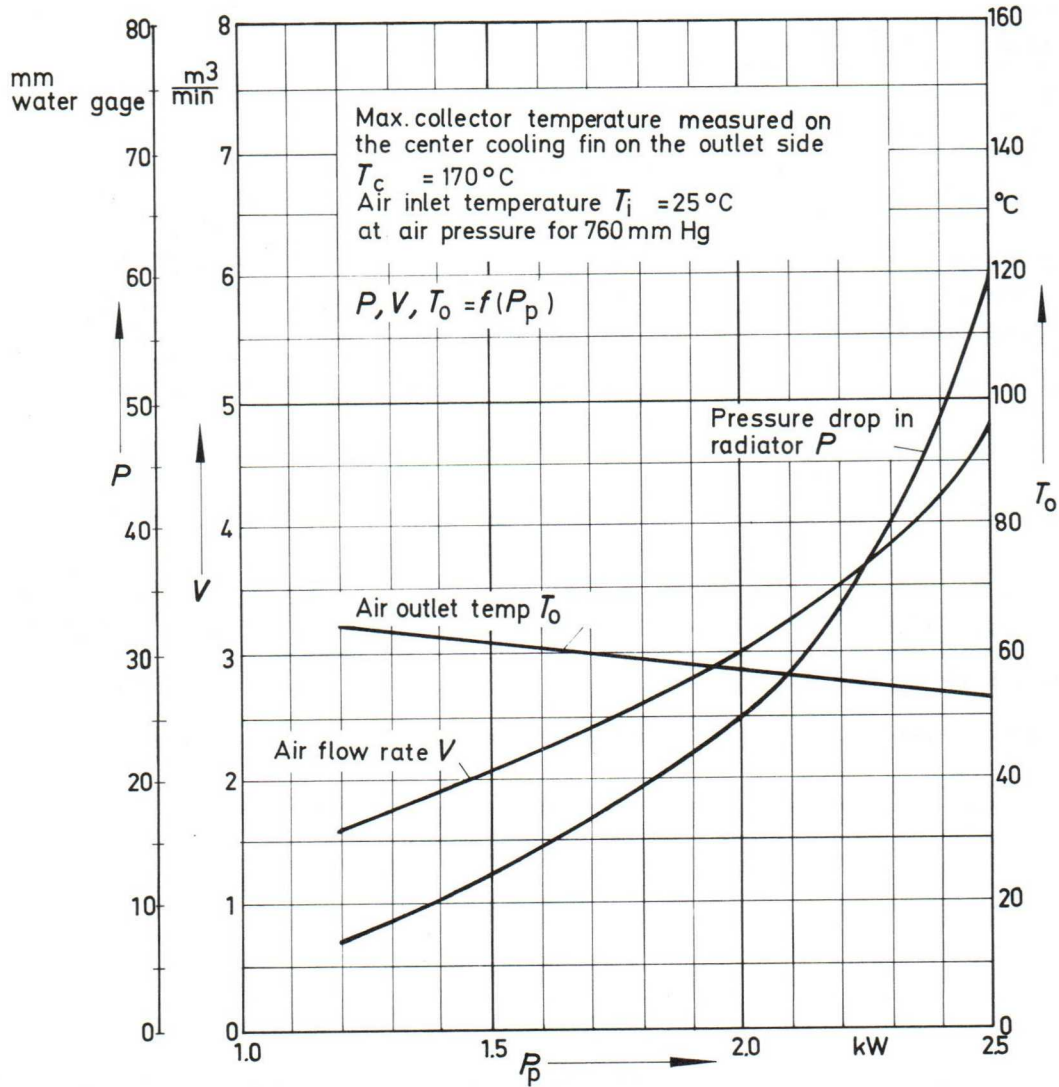

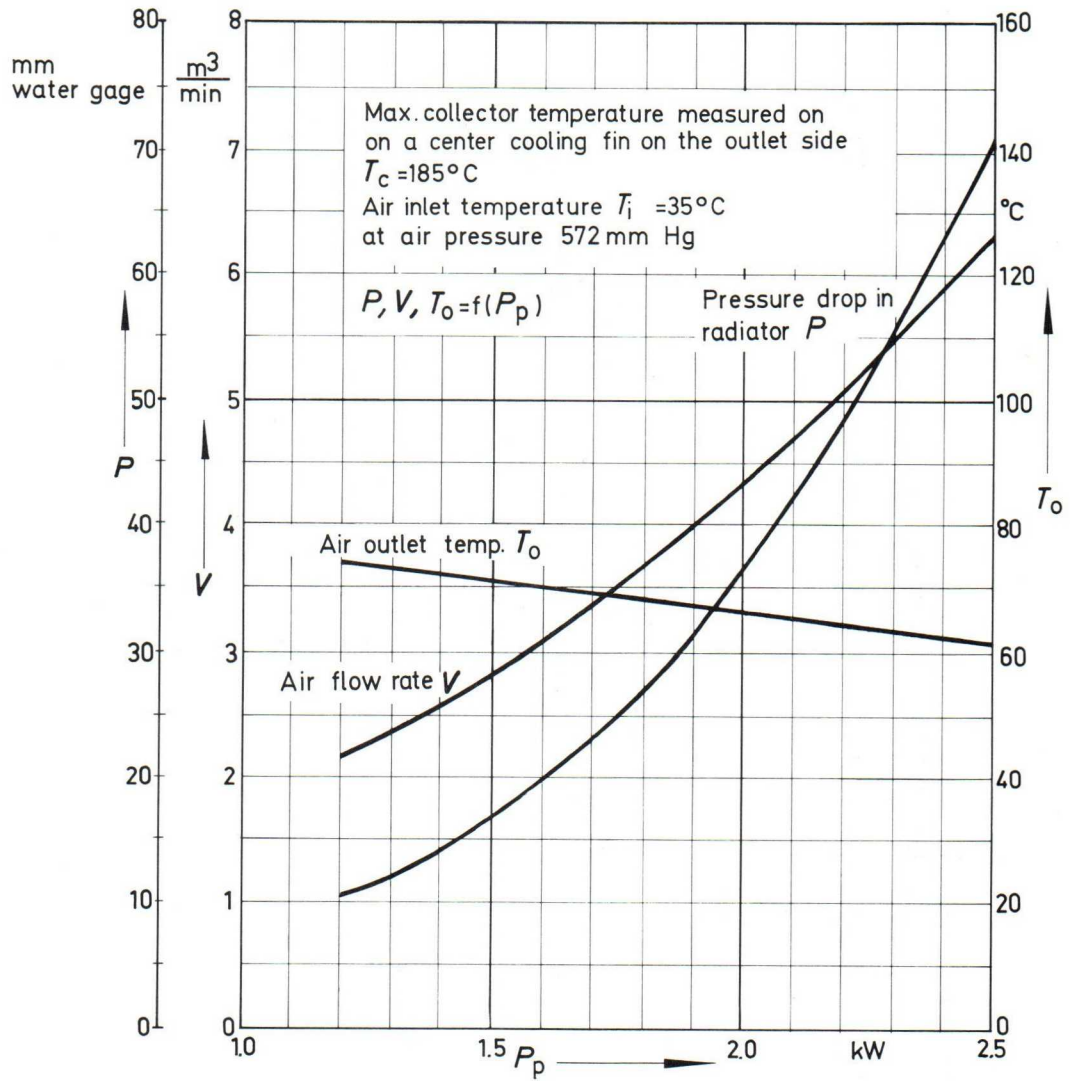

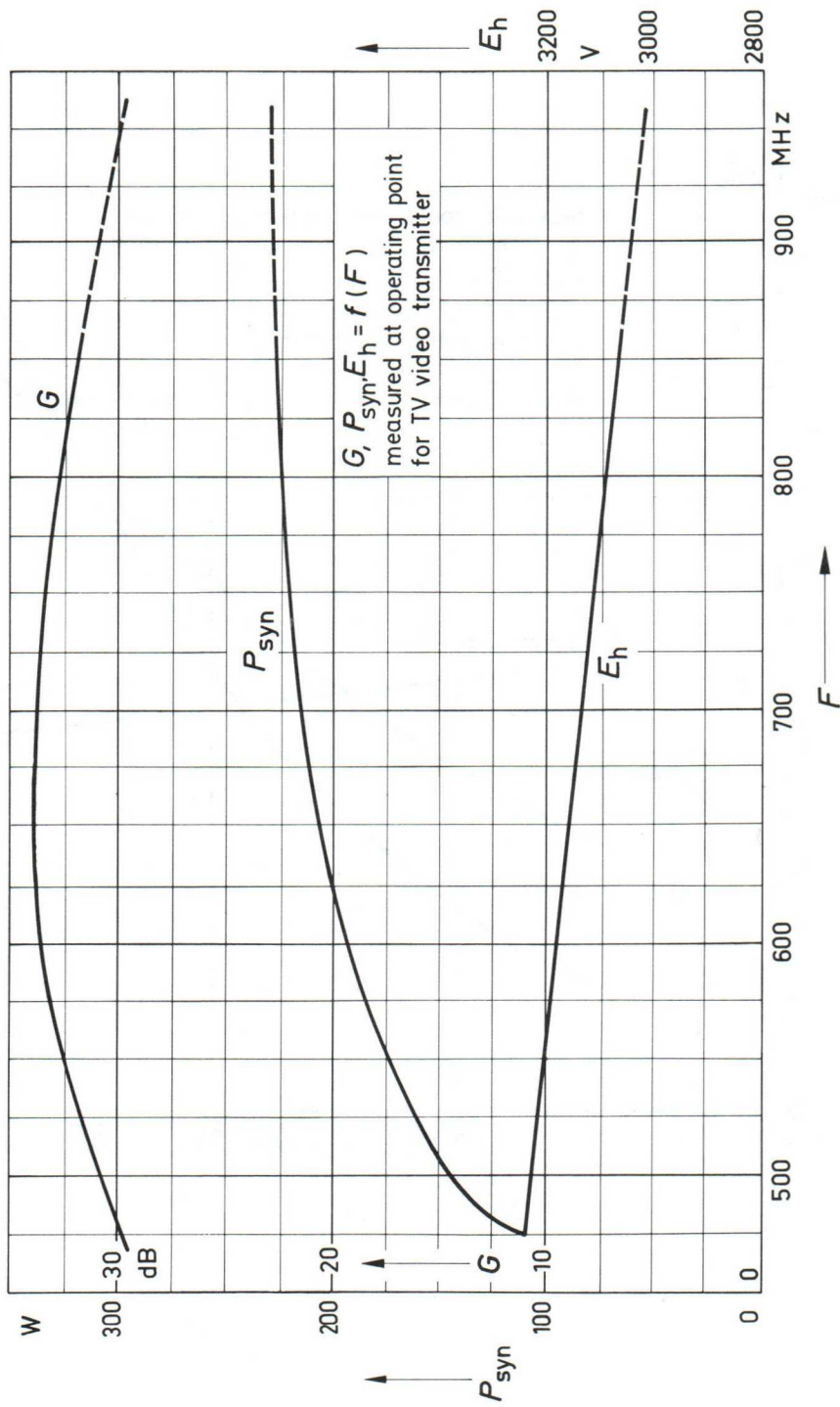

$$IM_3, G, E_h = f(F)$$

TV translator with concurrent
video and audio transmission

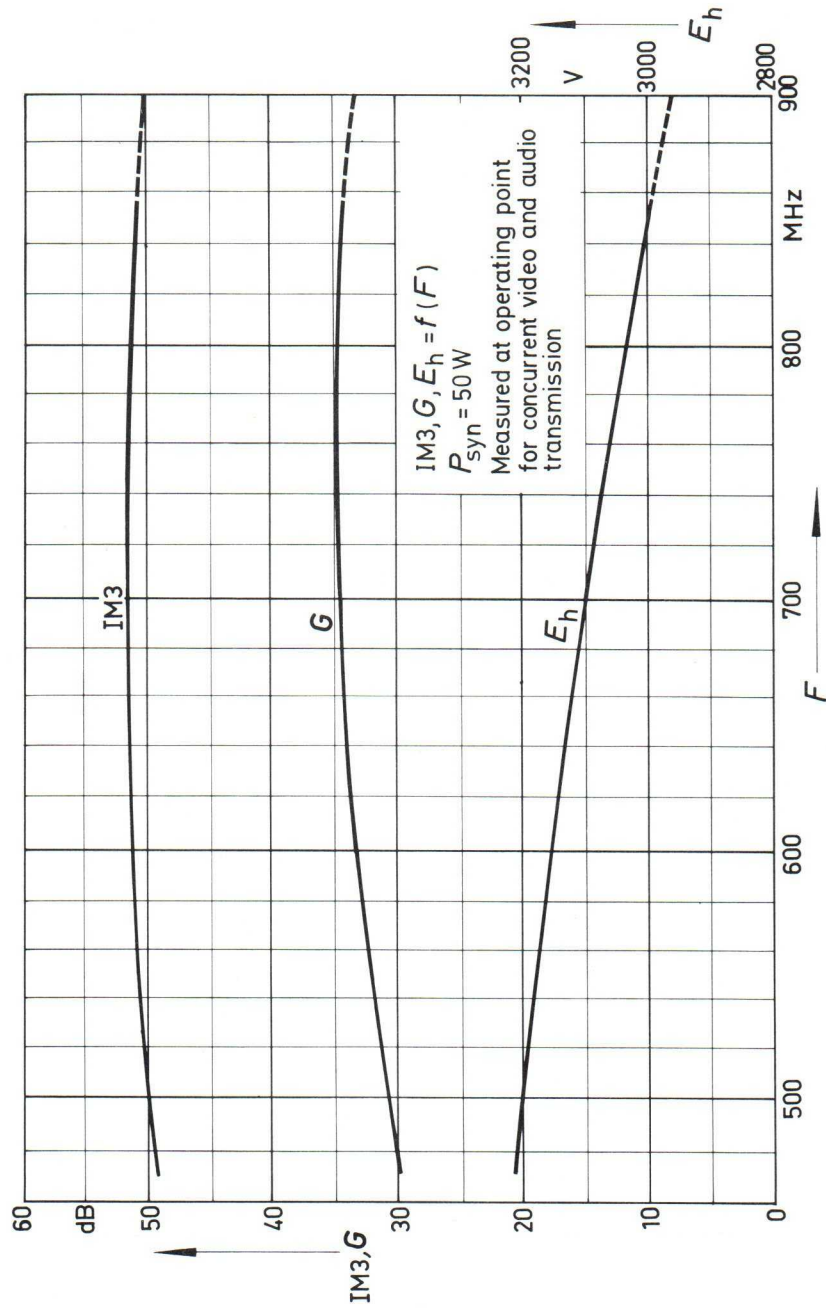

Characteristics

$$P_{\text{syn}} = f(E_h)$$

TV translator with concurrent video and audio transmission

YH 1020

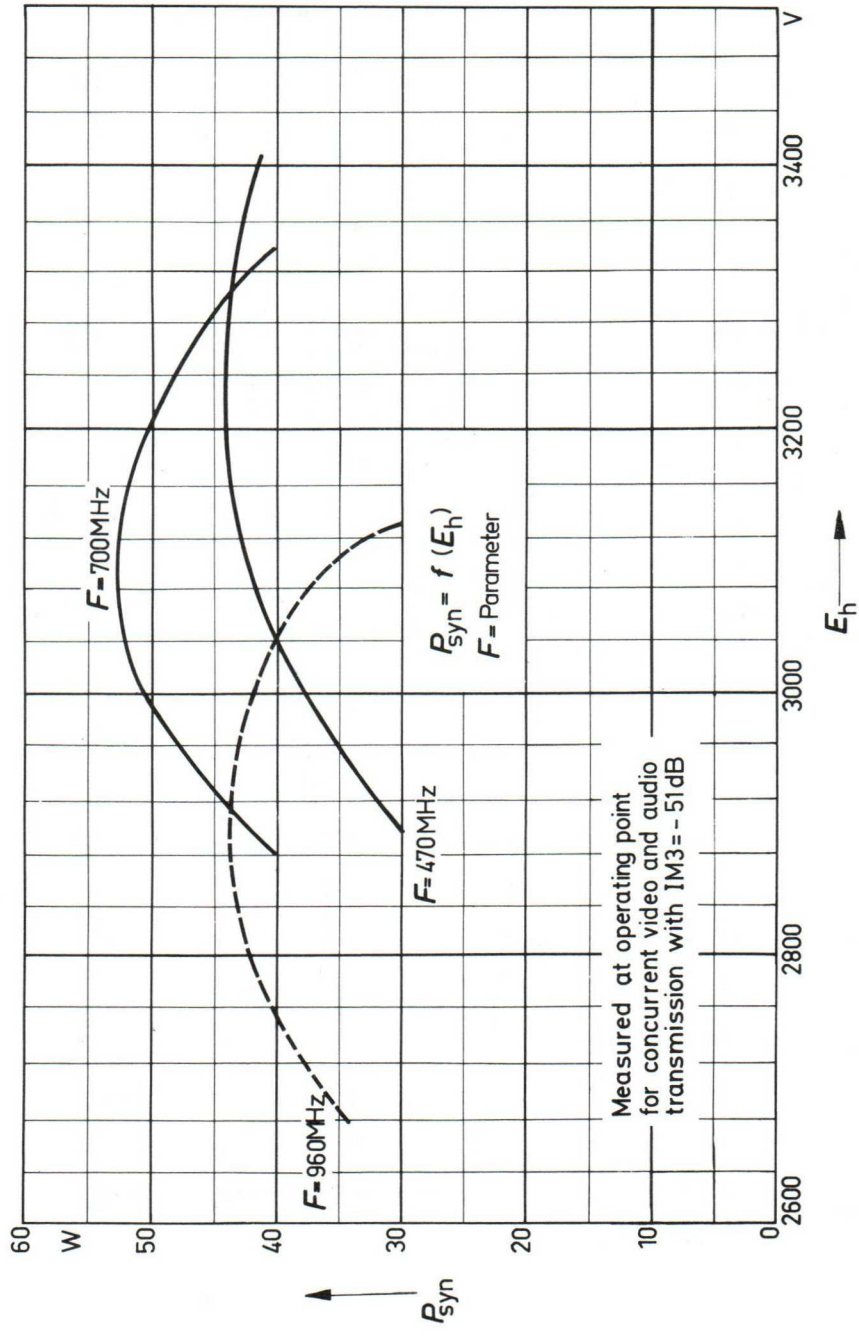

$$G = f(E_h)$$

TV translator with concurrent
video and audio transmission

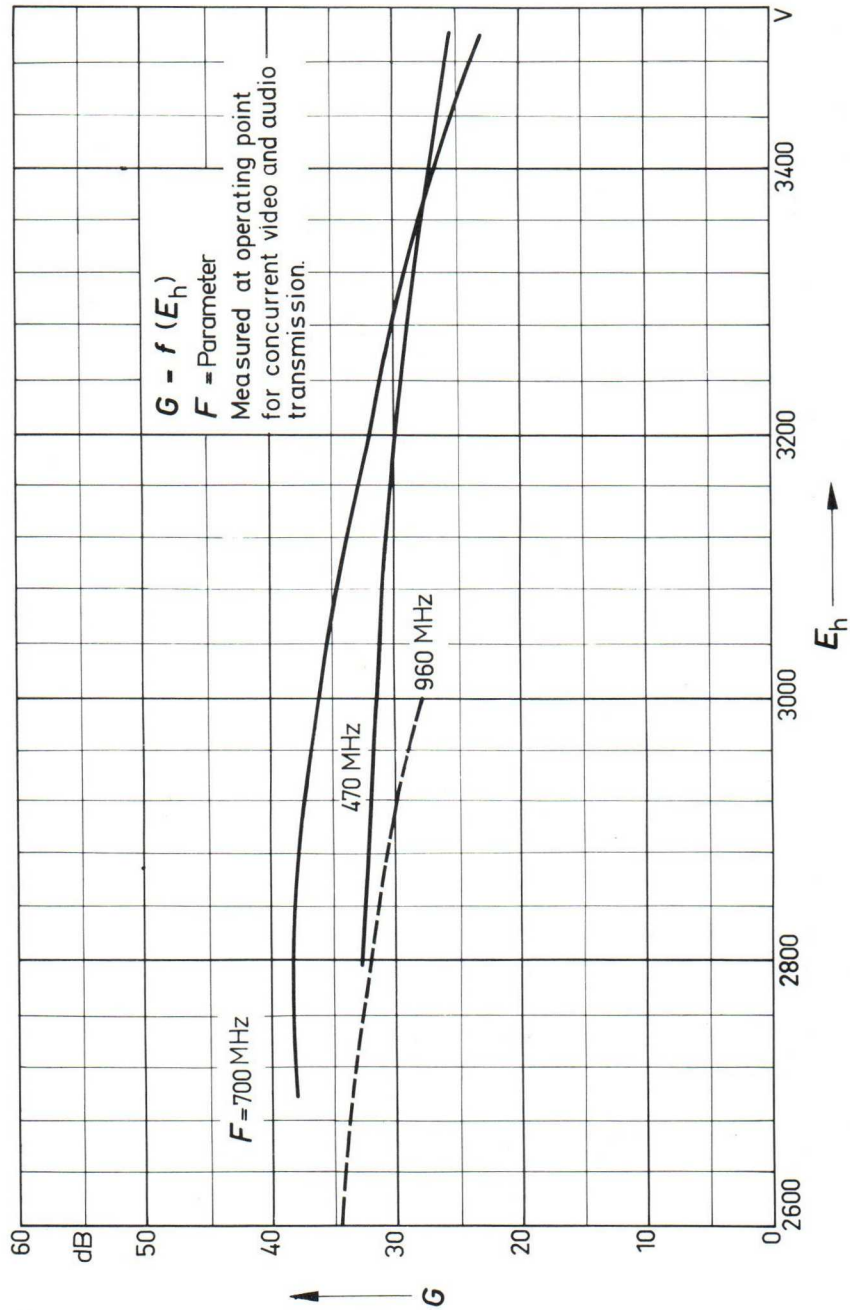

$$IM3, G, E_h = f(F)$$

TV translator with concurrent video and audio transmission, phase compensation

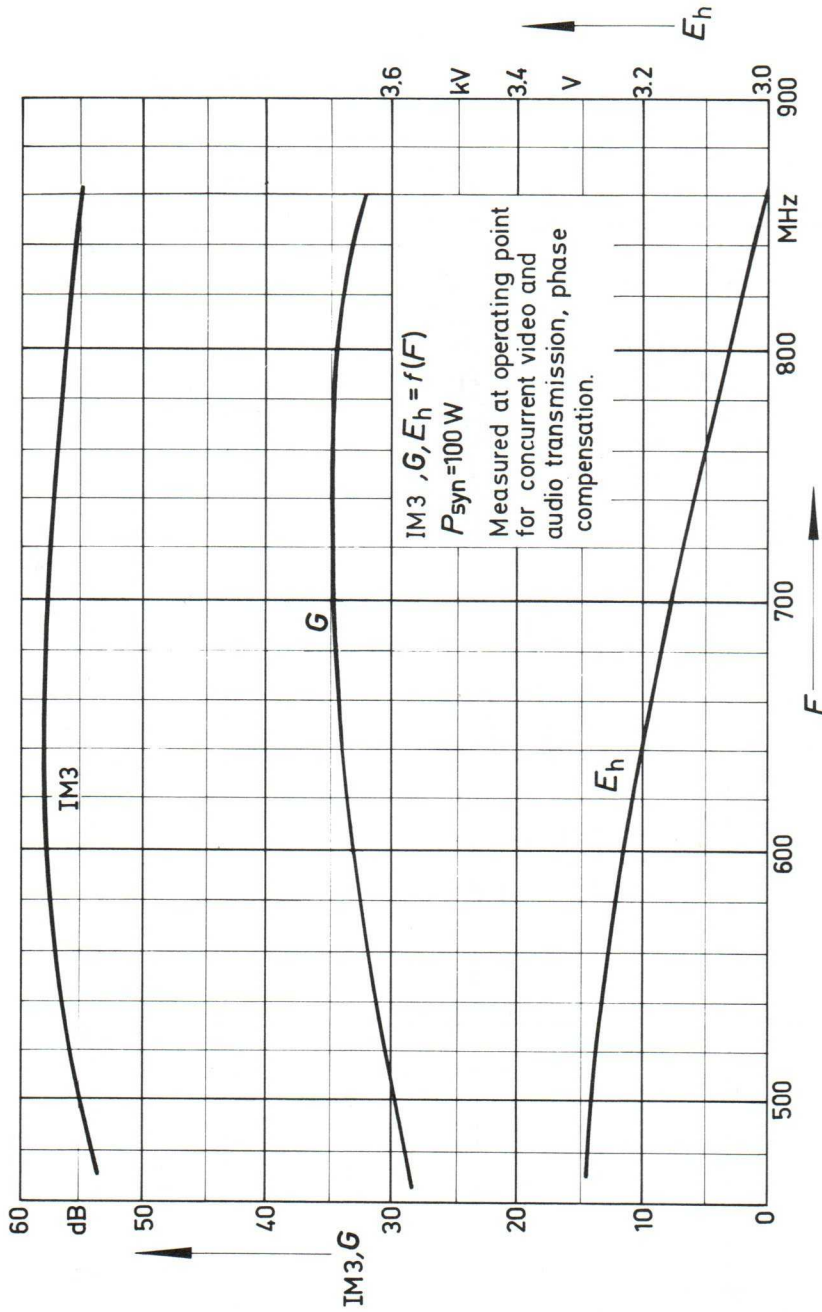

$$I_k = f(E_{c2})$$

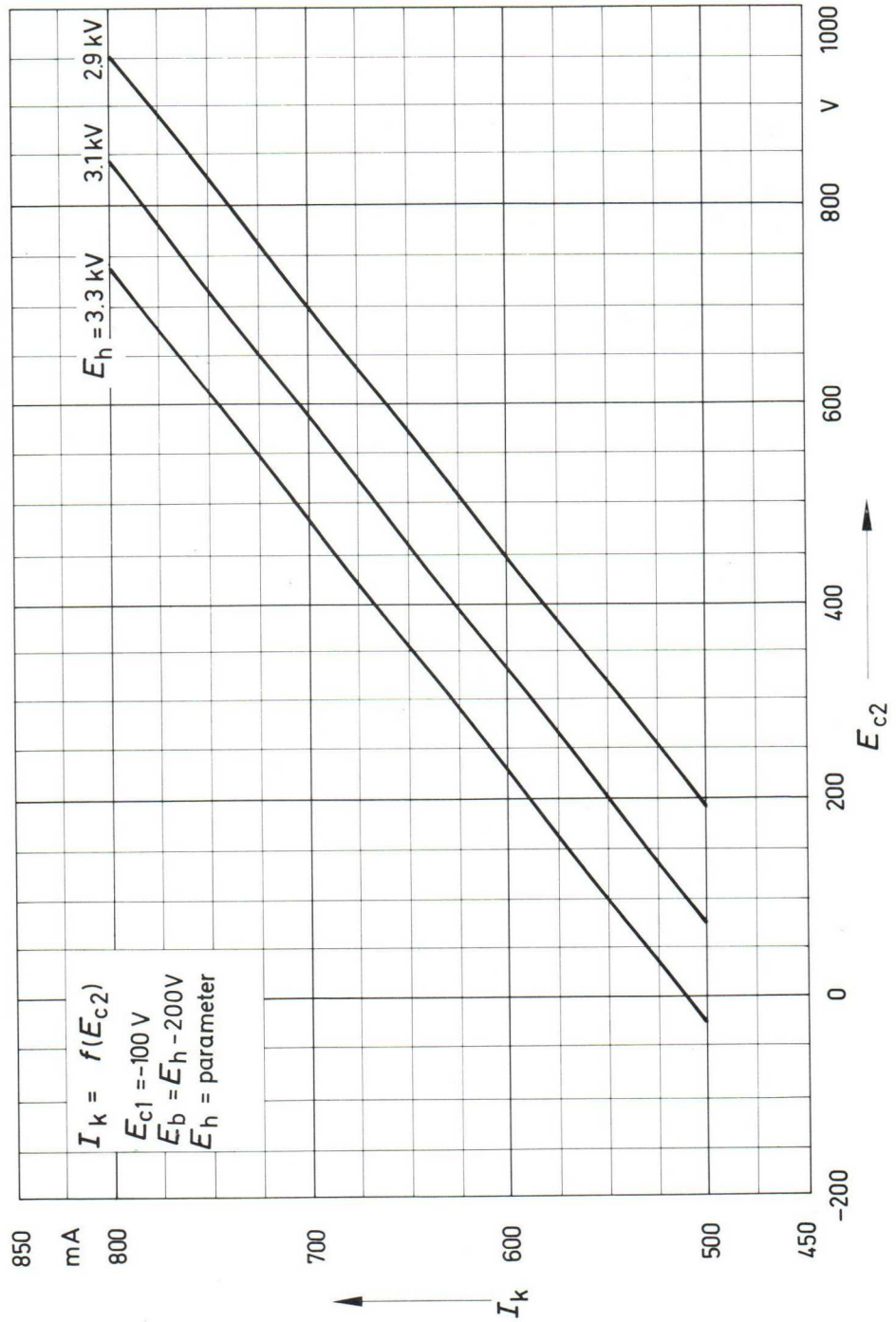

$$I_k = f(E_{c1})$$

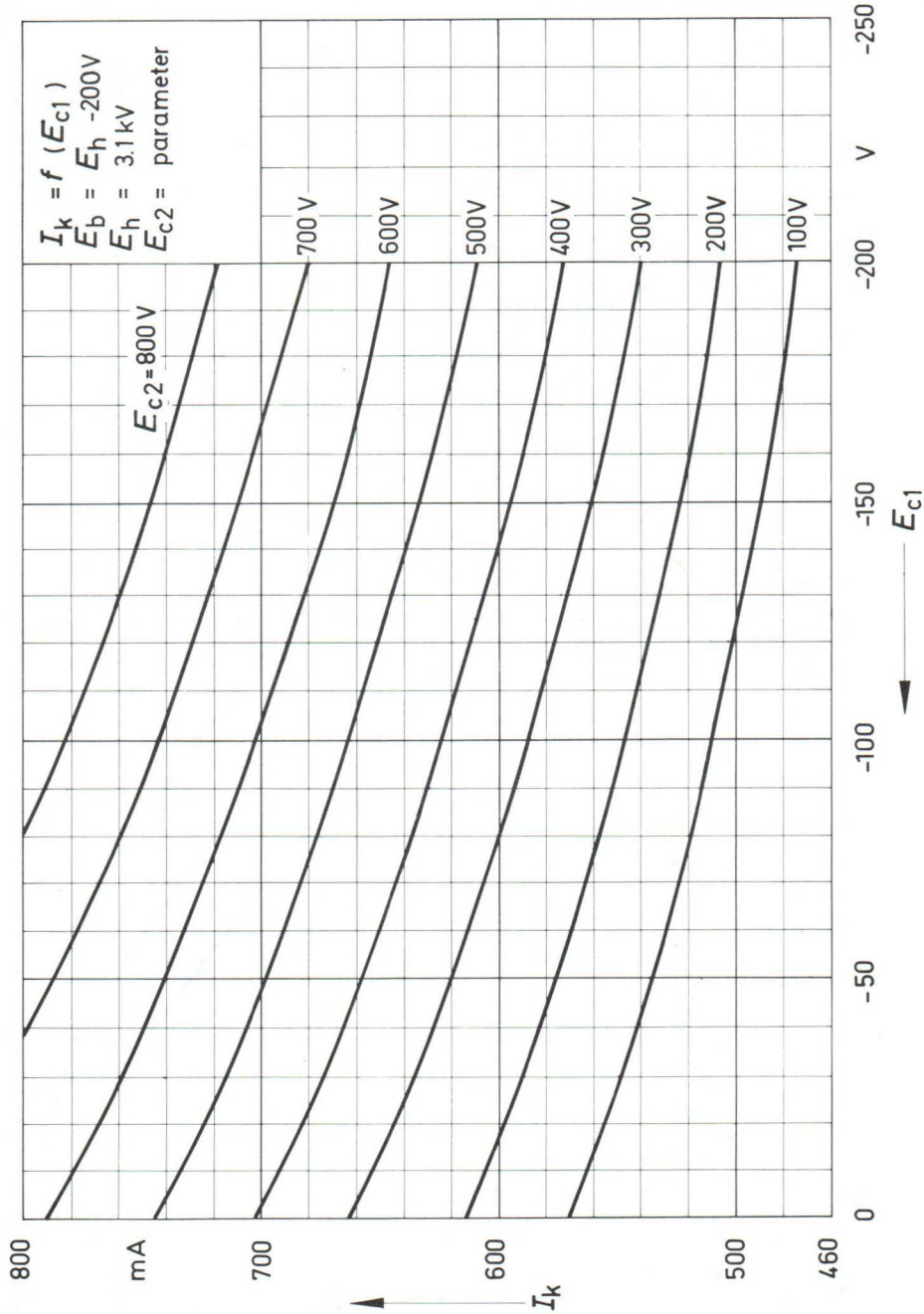

A UHF Transmitting Tube for TV

The YH 1020 Traveling-Wave Tube

Reprint from "Siemens Electronic Components Bulletin"
 I (1966) · 3 · pp. 66 to 70
 By Arnulf Rother

Due to its good linearity characteristics, the YH 1020 traveling-wave tube is particularly well suited for use in television transmitters and transposers in the frequency range 470 to 960 Mc. In common vision and sound transmission it delivers a peak sync power of 50 w in accordance with the requirements of Specification No. 5/6 of the Council of German Broadcasting Companies entitled "Fernseh-Kleinumsetzer für Bereich I, III, IV, und V". For separate vision and sound transmission the tube can supply up to 125 w with a 30-db gain in band IV and up to 200 w at the same gain in band V. The tube is focused by a permanent magnet and is field-replaceable in the magnetic system MHY 1020. The r-f input and output ports are coaxial connectors, the vswr throughout the frequency range being less than 1.85.

Constructional design of the tube

The YH 1020 is of metal-ceramic design (Fig. 1). The helix (1) is centered with the aid of three insulating rods (2) in a metal tube (4). Coaxial lines (5 and 6) are used for coupling the r-f power in and out. The support flanges (7 and 8) hold the tube in the magnet system. The main helix is terminated at either end in a transformation helix (9 and 10) which matches its characteristic impedance to that of the coaxial lines. The vswr in the frequency range 470 to 960 Mc has been lowered to less than 1.85 by means of this transformation. Fig. 2 shows the locus curve of the r-f input and output impedance. For r-f decoupling of the input and

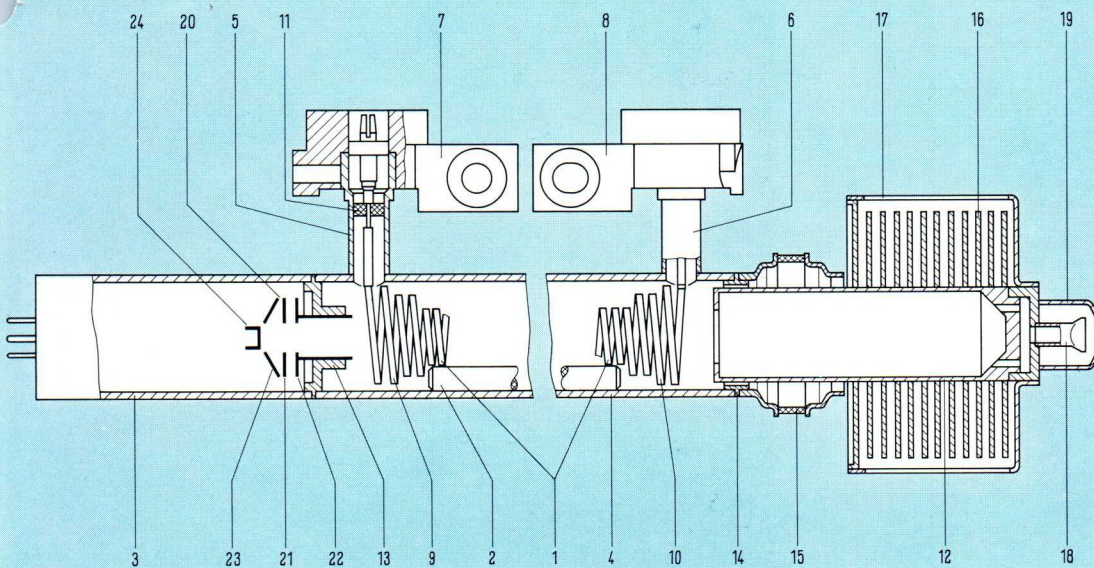

Fig. 1
 The YH 1020
 traveling-wave tube

- 1 Helix
- 2 Insulating rods
- 3, 4 Metal tube
- 5, 6 Coaxial lines
- 7, 8 Support flanges
- 9, 10 Transformation helix
- 11 Ceramic bead
- 12 Collector
- 13, 14 Centering flange
- 15 Ceramic ring
- 16 Cooling fins
- 17 Casing for cooling fins
- 18 Pump connecting piece
- 19 Protective cap
- 20 Electron gun
- 21 Apertured plate (grid 2)
- 22 Apertured plate (earth)
- 23 Wehnelt electrode (grid 1)
- 24 Cathode

output of the tube, the helix-supporting rods are partially coated with carbon. The surface resistance is so tapered that the vswr at the interface between the unattenuated helix and the attenuated helix will be sufficiently low. The slow-wave structure is long enough to guarantee a gain of at least 30 db in the tube throughout the frequency range.

The inner conductors of the coaxial lines which are held in place by ceramic beads (11) are soldered to the ends of the transformation helices. This method of connection offers the advantage that the helices can be heated by current flow during pumping and cathode formation to about 800 °C and thus make outgassing easier. The variation in characteristic impedance due to these ceramic beads can be compensated by reducing the cross section of those parts of the inner conductors which run through the ceramic beads. The beads are soldered vacuum-tight to the inner and outer conductors. The collector (12) is welded by way of a centering flange (14) to the metal outer tube (4). A ceramic ring insulator (15) is soldered between the collector and the helix. The cooling fins (16) of the collector are copper disks soldered to the collector, and their surfaces and spacings are so dimensioned that the collector temperature will not exceed 200 °C at an air flow of 106 cu.ft/min and a maximum dissipation of about 2.5 kw. The drop in air pressure between the inlet and outlet at the casing for cooling fins (17) is less than 1¹/₄" waterhead. The pumping stem (18) is soldered to the end of the collector and covered by a protective cap (19) in the finished tube. A centering flange (13) and an additional metal tube (3) support the plug-type electron gun (20) which, as is customary with all Siemens traveling-wave tubes, consists of a dispenser cathode (24), two apertured plates (21 and 22) and a Wehnelt electrode (23).

A hinged permanent magnet (Fig. 3) producing a constant axial magnetic field between the electron gun and collector focuses the electron beam. Small ferrite blocks mounted in stepped fashion on four iron bars at 90° to each other generate the field.

The field straightener (Fig. 3), consisting of a stack of alternating soft-iron and aluminum disks, is inserted between the magnetic system and the tube. This arrangement provides a highly uniform axial magnetic field. The field straightener has a longitudinal slot to permit it to be slipped over the tube with its lateral ports. An iron ring is used to adjust the cathode magnetic field. It is at the inlet side of the field straightener and can be adjusted externally by means of a knurled ring and a shifter rod (adjustment for minimum helix current).

Tube handling

The tube and its magnetic system can be operated in any position. Since its magnetic leakage is so low, the magnetic system need only be spaced a few inches from other magnetic materials.

The collector voltage is applied through a high-voltage cable permanently located in the magnet system; the helix voltage is connected to the terminal over which the magnetic system is grounded. The remaining electrodes are all connected to the power supply through a cable with screw socket.

The r-f connections have a special flange-type plug for which the following adapters can be supplied:

| | | |
|---|---------------|------|
| Adapter between special flange-type plug and: | | |
| BNC connector | (US standard) | 50 Ω |
| C-type connector | (US standard) | 50 Ω |
| N-type connector | (US standard) | 50 Ω |

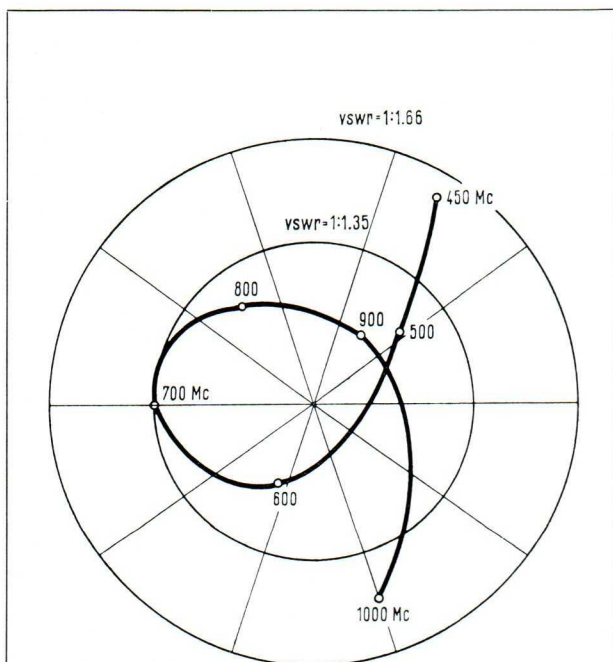
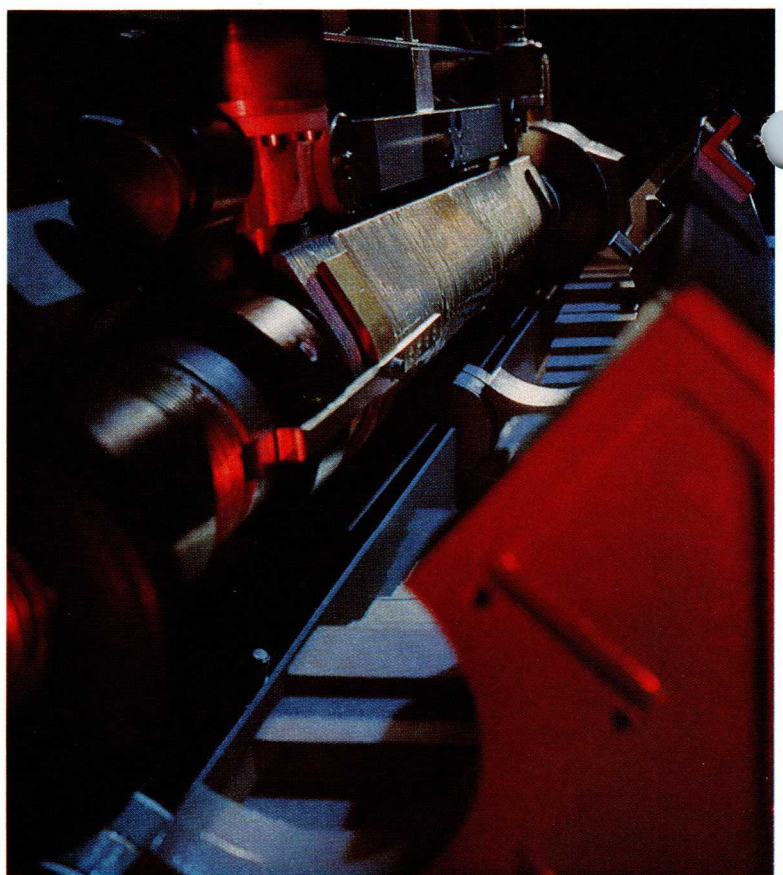

Fig. 2 Locus curve of the r-f input and output impedance

Fig. 3 YH 1020 traveling-wave tube with magnet system open



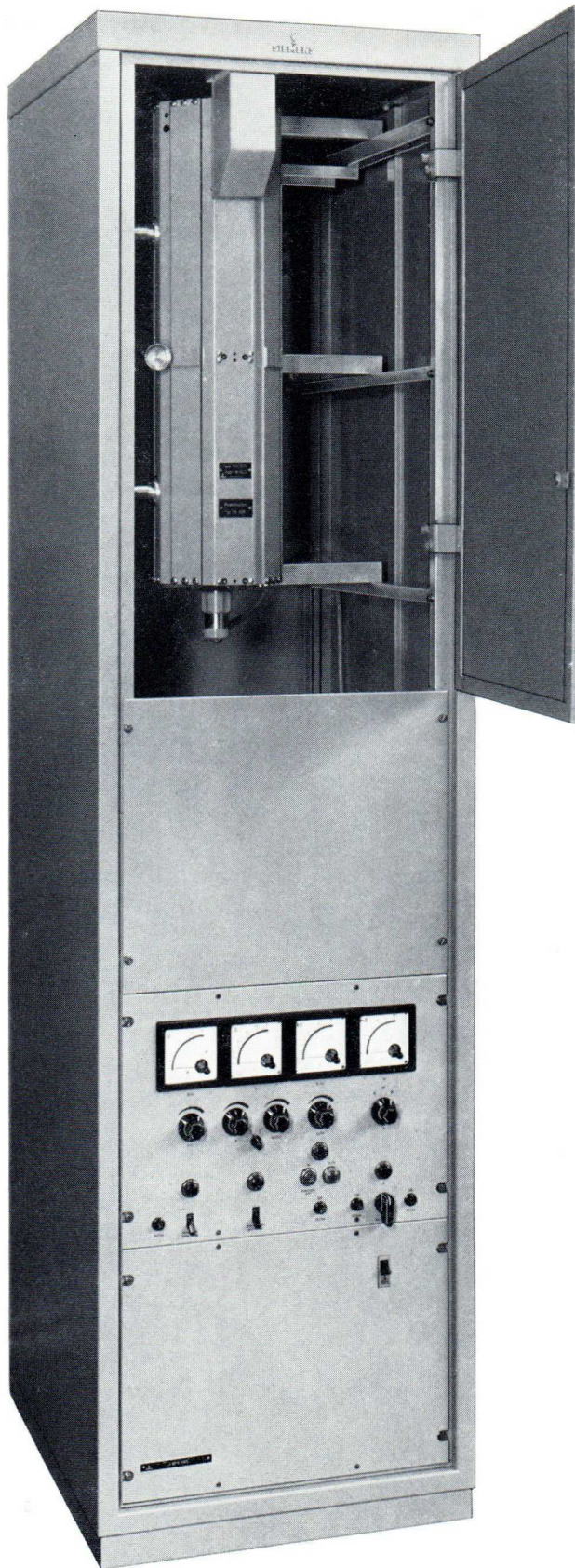

Fig. 4 19" cabinet with power supply, blank panel for preamplifier and panel for YH 1020 traveling-wave tube (top)

The tube is very easy to install and remove; first slip the field straightener over the tube and attach it by means of a knurled retaining screw at the mounting flange. Put this unit into the opened magnet system and secure it with two nuts. Close the magnet system and then screw on the tube connector and the two r-f flange plugs. Once this is completed, the tube is operational. Since the tube operates without resonant circuits

throughout its frequency range of 470 to 960 Mc, no tuning is necessary when tubes or frequencies are changed.

It can be delivered with a 19" standard cabinet including power supply and blower (Fig. 4). The lower part contains the power supply unit with controls and monitoring instruments. Immediately above this section is a blank panel 16" in height, behind which the converter input stage can be placed. Above this is the magnet system with the tube, the blower assembly being installed at the top. The power supply unit supplies all voltages required for operation of the tube:

6.3 v heater voltage, 3.5 kv insulated:

2.7 to 3.3 kv collector and helix voltage at a cathode current of 750 ma.

A 270-Ω resistor is connected in series with the collector to drop the collector voltage 200 v below the helix voltage.

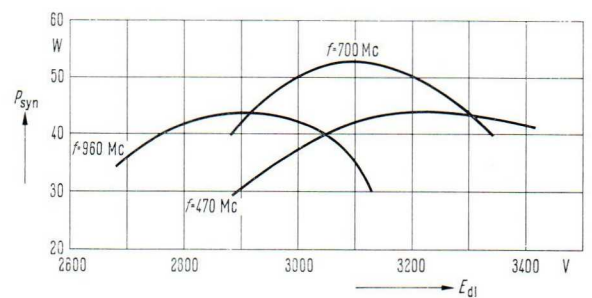

Fig. 5 Output power P_{syn} as a function of the helix voltage E_{d1} , for a -34 db interval of the intermodulation products from the black-white step with simultaneous picture and sound transmission

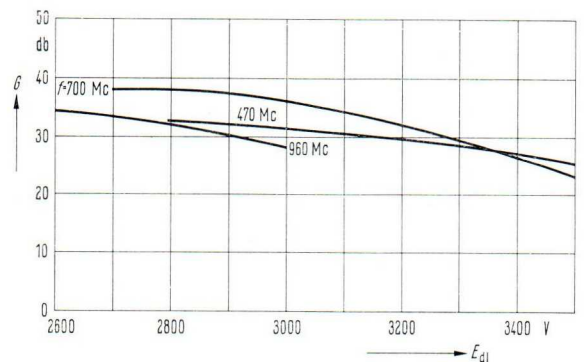

Fig. 6 Power gain G as a function of helix voltage E_{d1} for frequencies of 470, 700 and 960 Mc with simultaneous transmission of picture and sound

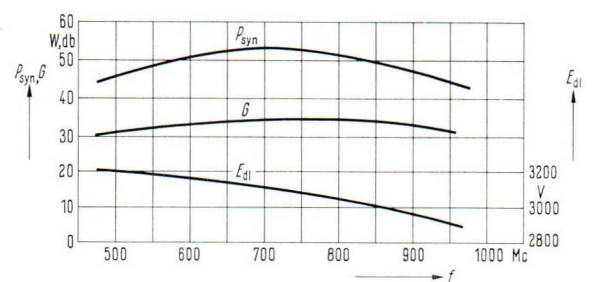

Fig. 7 Output power P_{syn} , power gain G and helix voltage E_{d1} as a function of frequency F under the same conditions as in Fig. 5

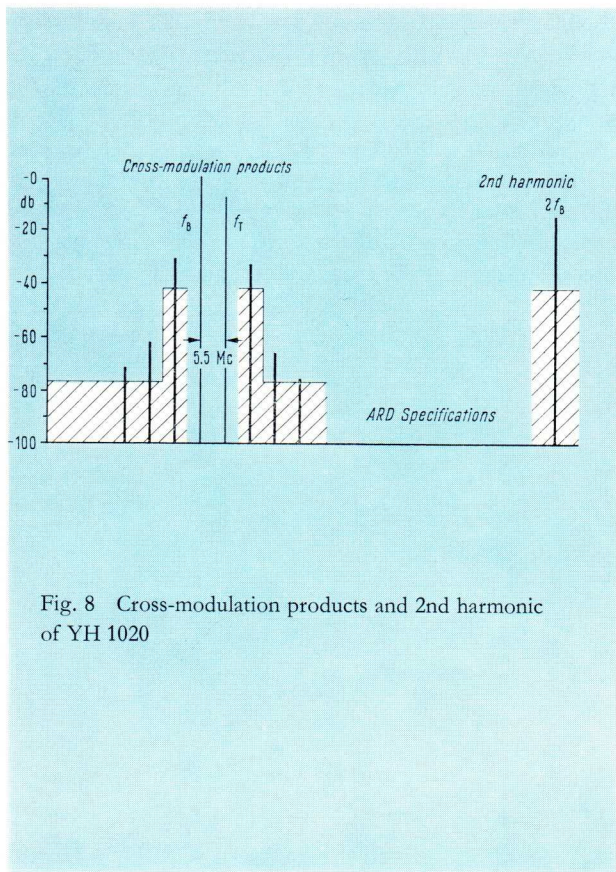

Fig. 8 Cross-modulation products and 2nd harmonic of YH 1020

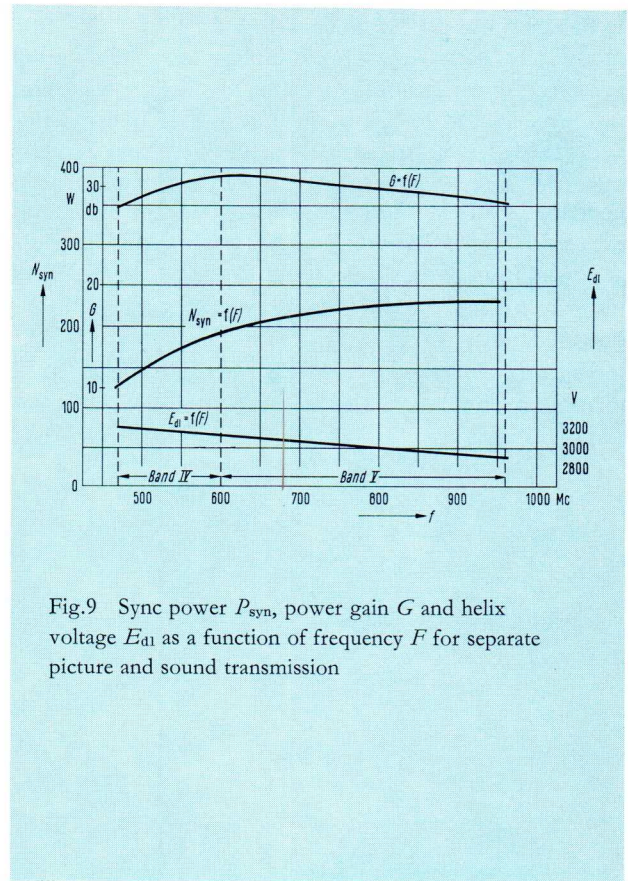

Fig. 9 Sync power P_{syn} , power gain G and helix voltage E_{d1} as a function of frequency F for separate picture and sound transmission

The grid No. 1 voltage of -100 v is obtained via a cathode resistor and the 450 to 1000 v for the grid No. 2 voltage are taken from a voltage divider across the helix voltage. Automatic cathode-current stabilization controls the grid No. 2 voltage and thus ensures that the tube will have constant r-f characteristics throughout its life.

R-f characteristics

In view of its favorable linearity characteristics, the YH 1020 is well suited for use in television transposers with common vision and sound transmission. The specifications of the German Broadcasting Companies for small tv transposers require that the intermodulation products from the modulated vision carrier and the sound carrier with the input level at its maximum must not exceed -34 db against the black-to-white step within the channel (measured peak-to-peak). This requirement limits the maximum power output of the tube. A measurement according to these specifications will require three signal generators, each with a different level.

When measuring the third harmonic distortion factor, the same result can be obtained by a simple mathematical conversion. The difference is that this method requires only two signal generators with levels which are 6 db below peak sync. The relation between either of these amplitudes and the first cross-modulation product to appear is designated the third harmonic distortion factor d_3 . The cubic term of the characteristic curve $e_0 = a_1 e_i + a_2 e_i^2 + a_3 e_i^3 + \dots$ ¹ shows that the specification requirements amount to a distortion factor of -37 db. This theoretical fact has been substantiated by

actual measurements. Fig. 5 shows the peak sync output for a constant intermodulation product of -34 db as a function of the helix voltage with the frequency as parameter. It is advisable to operate the tube at the peaks of these curves. A comparison with Fig. 6, in which gain is plotted as a function of frequency, shows that the maximum gain is achieved at a helix voltage which is about 400 v lower than that at which the best linearity is obtained.

The curves shown in Fig. 7 are obtained from Figs. 5 and 6, the operating points chosen being those for optimum linearity. For common vision and sound transmission the maximum peak sync output is 53 w, achieved at 700 Mc. At the band limits of 470 and 960 Mc the output drops to 43 w. At 750 Mc the maximum gain is 35 db, and it drops at the band limits by about 4 db. The helix voltage to be selected for optimum linearity is shown in Fig. 7; it is 2900 v at the highest frequency and increases to 3200 v as the frequency decreases.

In trial transmissions of monochrome test patterns with measurements at 600 Mc and up to 100 w peak sync output no deterioration in picture could be detected. A further increase of the output to about 150 w caused Moiré interference which was so weak, however, that it would not be discernible on a normal television set. The tube has also been used in trial transmissions of color pictures by the NTSC and PAL methods and the transmitted color test pattern at 600 Mc was examined. In a subjective picture evaluation no noise could be discerned for a nominal output up to 200 w.

One characteristic deserving special mention is the constancy of the linearity of this traveling-wave tube if the cathode current is kept constant.

For transposer applications, the harmonic and intermodulation products of the tube are also of critical importance. One of the requirements of the specifica-

1 e_i R-f input voltage
 e_o R-f output voltage

tions is an interval of more than -40 db for the harmonics and of less than $1 \mu\text{w}$ for the cross-modulation product. An exception is made for the cross-modulation products at 5.5 Mc below the vision carrier frequency and 5.5 Mc above the sound carrier frequency; in this case only a noise interval of more than 40 db is specified. Fig. 8 shows the requirements (shaded areas) and the cross-modulation products and the second harmonic at the output of the tube (bold lines). A simple filter must be added in order for the specified values to be obtained.

If the tube is used only as a vision transmitter, it is possible to operate with the peak sync output up to

about half the maximum output. In Fig. 9 the maximum output and the peak sync output have been plotted as a function of the frequency. At 470 Mc the peak sync output is at its lowest point of 125 w, and at 600 Mc at the beginning of band V it is already up to 200 w. The picture also shows the corresponding helix voltage and the gain. For color tv applications the differential phase and the differential gain of the color subcarrier are also of interest: at the sync output shown in Fig. 9, 2.5° differential phase and 1.5% differential gain appear up to the black level. Due to the large bandwidth of this traveling-wave tube group delay differences never reach measurable levels within a television channel.

