

Specification MOS(A)/CV2752 Incorporating MIL-E-1/41 D Issue 2 Dated 12. 8. 55 To be read in conjunction with K1006	<u>SECURITY</u>	
	<u>Specification</u>	<u>Valve</u>
	UNCLASSIFIED	UNCLASSIFIED

—————> Indicates a change

TYPE OF VALVE - Tetrode Pulse Amplifier CATHODE - Indirectly-heated ENVELOPE - Glass PROTOTYPE - 4PR60A		<u>MARKING</u> K1001/4 <u>Additional Marking</u> 4PR60A	
<u>RATING</u>		<u>BASE</u>	
		Ceramic Wafer per Outline on Page 4	
		<u>CONNECTIONS</u>	
		<u>Pin</u>	<u>Electrode</u>
		1	Heater
		2	Screen Grid
		3	Control Grid
		4	Heater & Cathode
		TC	Anode
		<u>TOP CAP</u>	
		CT3 Sec BS.448 : 6/1.3	
		<u>DIMENSIONS</u>	
		Per Outline on Page 4	
		<u>Dimension(Ins)</u>	<u>Min.</u> <u>Max.</u>
		Seated height	5 11/32 5 19/32
		Diameter	- 3 1/16
		Overall length	5 3/4 6
		<u>MOUNTING POSITION</u>	
		Any	
<u>CAPACITANCES (pF)</u>			
Cag (max)	2.0		
Cin (nom)	42.5		
Cout (nom)	8.5		
		<u>NOTES</u>	
A. All limiting values are absolute. B. Duty cycle shall not exceed 0.001. For peak currents exceeding 5.0A the product of peak current in amperes and pulse duration in microseconds shall not exceed 40 and the valve shall not be operated for longer than 5 usecs in any 100-usec interval. For peak currents not exceeding 5.0A the anode dissipation of 60W shall determine the permissible pulse length. At higher duty cycles the peak current must be reduced in proportion. In applications where the peak current drawn is less than the maximum rating, the heating-time may be reduced proportionately. In no circumstance however, shall it be less than 60 secs. The screen grid decoupling series resistance shall be 20k min.			

Z.10085.R.

CV 2752

MIL-E-1/41D
 11 March 1955
 SUPERSEDING
 MIL-E-1/41C
 26 October 1954

INDIVIDUAL MILITARY SPECIFICATION SHEET
 ELECTRON TUBE, TETRODE, PULSE AMPLIFIER, TRANSMITTING

JAN-4PR60A

This specification forms a part of the latest issue of Military Specification MIL-E-1.

Ratings:	Ef	eb	Eb	Ecl	ecl	Ec2	Pp	Pg2	tk	ib	Seal Temp.	Alt
Absolute	V	kv	kVdc	Vdc	v	kVdc	W	W	sec.	a	°C.	ft.
Maximum:	26.0/10%	25.0	20.0	-1000	300	1.5	60	8.0	180	18	200 (max)	10,000
									(min)	Note 1		
Test Cond.:	27.0	---	1.2	---	---	1.0	---	---	180	---	---	---
									(min)			

**Base: Ceramic wafer per outline
 **Pin No.: Per Outline

*Dimensions: Per Outline
 **Cathode: Coated Unipotential

For miscellaneous requirements see paragraph 3.2, Inspection Instructions for Electron Tubes.

Ref.	Test	Conditions	Min.	Max.
3.1	Qualification Approval:	Required for JAN Marking		
4.9.18.1.5	Carton Drop:	(d) Package Group 1; Carton Size N		
4.5	Holding Period:	t=72 hrs.		
4.9.5.1	*Torque:	Note 2		
4.9.19.2	*Vibration:	No voltages; t=120; Note 3		
4.9.20.3	**Vibration:	Ef=24Vdc; Ebb=250Vdc; RL=2500; Ec2=90Vdc; Ec/Ib=5mAdc	Ep: ---	1.5 Vac
4.9.20.5	Shock:	Hammer angle=13°; Notes 6 and 7 Ef=27.0V; No other voltages		
---	Post Shock Test End Points:	Operation (1) Operation (1)	iL: 20 ΔiL: ---	--- a 10%
4.10.8	*Heater Current:		If: 1.95	2.35 A
4.10.6.1	Grid Current(1):	Ecl/Ib=50mAdc; Note 4	Ic1: 0	-20 uAdc
4.10.6.2	Grid Current(2):	Ecl=-500Vdc	Ic1: 0	-40 uAdc
4.10.4.3	Screen Current:	Ecl/Ib=100mAdc; Eb=150Vdc; Ec2=100Vdc	Ic2: 0.00	5.0 mAdc
4.10.5.2	Grid Voltage (1):	Ecl/Ib=50mAdc	Ecl: -190	-290 Vdc
4.10.5.2	Grid Voltage (2):	Ecl/Ib=1.0mAdc	Ecl: ---	-400 Vdc
4.10.6.2	Primary Screen-Grid Emission:	Plate Floating; Ecl=0; Ic2=100mA; Note 8; t=15	Isg2: ---	250 uAdc
4.10.13	Peak Emission:	eb=ecl=ec2=1000v; Ef=25Vac; tk=300 minimum	is: 35	--- a

<u>Ref.</u>	<u>Test</u>	<u>Conditions</u>		<u>Min.</u>	<u>Max.</u>	
4.10.23	Operation Test (1):	Ef=25V; Ebb=25kVdc; Ec1=-800Vdc; Ec2=1.35kVdc; RL=1030-1070 ohms; t=300 maximum; Note 5	iL: ΔiL:	20 ---	---	a 10 %
---	*Operation Test (2):	Ef=25V; Ebb=20kVdc; Ec1=-800Vdc; Ec2=1.25kVdc; RL=1050-1100 ohms; t=300 maximum; Note 5	iL: ΔiL:	15 ---	---	a 10 %
4.10.4.3	Screen Current:	Operation Tests (1) and (2)	Ic2:	Never Negative		
4.10.14	**Capacitance:		Cgp: Cin: Cout:	--- 35 6	2 50 11	uuf uuf uuf
4.11	Life Test:	Group G; Ef=25V; Ebb=20kVdc; Ec1=-800Vdc; Ec2=1.25kVdc; RL=1030- 1070; Du=0.001; Note 5; Note 9	t:	500	---	hrs.
4.11.4	Life Test End Point:	Operation Test (1)	iL: ΔiL:	19 ---	---	a 15 %
		Grid Current (1)	Ic1:	---	400	uAdc
		Peak Emission	is:	35	---	a ←
		Primary Screen-Grid Emission	Isg2:	---	250	uAdc

Note 1: (a) Duty shall not exceed 0.001. For peak currents in excess of 5 amperes, the product of peak current in amperes and pulse duration in microseconds shall not exceed 40, and the tube shall not be operated longer than 5 microseconds in any 100-microsecond interval. For peak currents less than 5 amperes, the plate rating of 60 watts shall determine the allowable pulse interval. At higher duty cycles the peak current must be reduced in proportion. In applications where the peak current drawn is less than the maximum rating, the heating time may be reduced in proportion. In no case however, can it be less than 60 seconds.

(b) Screen grid decoupling series resistance shall be 20,000 ohms minimum.

Note 2: The base shall be subjected to a gradually applied torque of 12.0 pound-inches. This test shall not cause broken leads, broken welds, broken soldered joints, broken or cracked glass.

Note 3: Vibrate the tube in a direction perpendicular to the axis of the tube with the tube in a vertical position, first, base down, and second, base up. Tube should be vibrated in each position two minutes.

Note 4: Tube to operate with constant or decreasing grid current for two minutes. If the tube should operate with a rise of grid current, the grid current shall become constant or decrease within five minutes.

Note 5: (a) Driver pulse duration 2us minimum, measured at 95% of maximum amplitude. Time of rise less than 0.2us, time of fall less than 0.4us. Variation of amplitude over 80% of top portion of pulse not more than 5%. Recurrence frequency 300 to 500 pps. Exact frequency at the option of the manufacturer.

(b) Input signal to control grid shall drive the grid positive by 225/25 volts at the top of the pulse.

(c) The variation of amplitude of the output pulse shall not be greater than specified.

(d) Tube shall operate for a two minute period without sparking within the tube either at rest or when subjected to shock not to exceed 10 G.

(e) Tube shall be tested in the circuit shown.

(f) A Westinghouse type MN overcurrent relay, style 1158584 (Navy type GAY29095) which has a 50-200 mAdc range shall be used in conjunction with an ac control relay in operation testing and life testing of this tube type. The dc overcurrent relay shall be equipped with coil No. 1158382 and shall be adjusted to 200 mAdc. The ac control relay used in conjunction with the dc over-current relay shall open the ac line approximately 20 milliseconds after the overcurrent relay opens. A device shall be incorporated into the relay circuit which will delay the reapplication of plate voltage for a minimum period of 15 seconds after each kickout and shall count the number of kickouts.

- Note 6: The retainer shall be in accordance with the 179-JAN Drawing or equivalent.
- Note 7: For acceptance sampling procedure, see paragraph 5.2 of Inspection Instructions for Electron Tubes.
- Note 8: Primary screen-grid emission is to be made in a circuit with suitable rectifiers and resistors to limit the voltage applied to the screen-grid during the heating half cycles while allowing the emission measurement to be made at 750 volts rms during the measuring half cycles.
- Note 9: During the life test, any tube which will kick-out the over-current relay more than 24 times in a 24-hour period shall be considered a failure.
- Note 10: Reference specification shall be of the issue in effect on the date of invitation for bid.

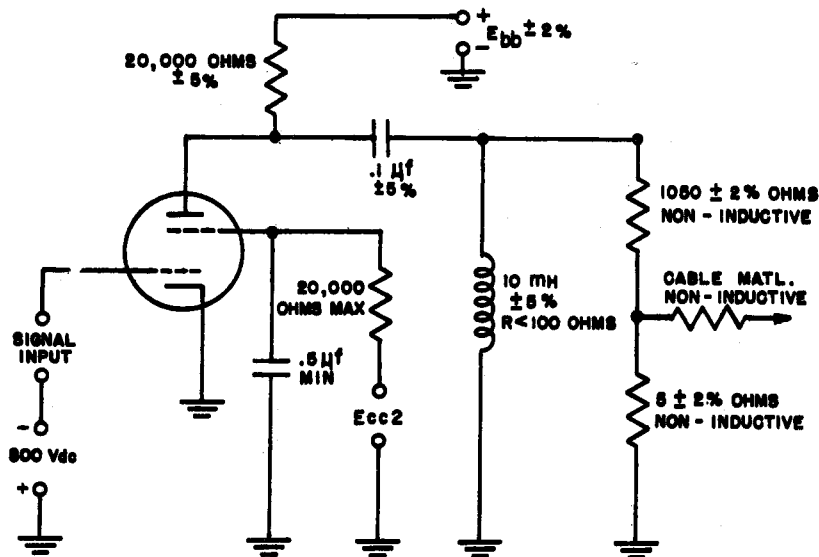

CIRCUIT FOR OPERATION TEST

CV2752

REF	DIMENSION
A	* $5\frac{7}{8} \pm \frac{1}{8}$
B	* $3\frac{1}{16}$ MAX DIA
C	** $5\frac{15}{32} \pm \frac{1}{8}$
D	** $1\frac{3}{16} \pm \frac{1}{16}$
E	* 2.895 ± 0.015 DIA
F	** $\frac{21}{64}$ MIN STRAIGHT SIDE
G	** $\frac{15}{32} \pm \frac{1}{32}$
H	** .016 MIN
J	** $.566 \pm 0.007$ DIA
K	** $\frac{7}{16}$ MIN STRAIGHT SIDE
L	** $.187 \pm 0.016$
M	** $.187 \pm 0.016$
P	** .687 NOM
Q	* 1.8005 ± 0.0125
R	** .687 NOM
S	** $\frac{1}{8}$ NOM
T	** $.187 \pm 0.004$ DIA 5 PINS
V	** $1\frac{1}{8}$ DIA NOM
W	** $\frac{1}{4}$ NOM
X	** $\frac{3}{16}$ NOM
Y	** $\frac{1}{2}$ MAX
Z	** $\frac{1}{4}$ MIN
AA	** $\frac{1}{8}$ MAX
AB	** $\frac{1}{8}$ MIN
AC	* $.050 \pm 0.007$

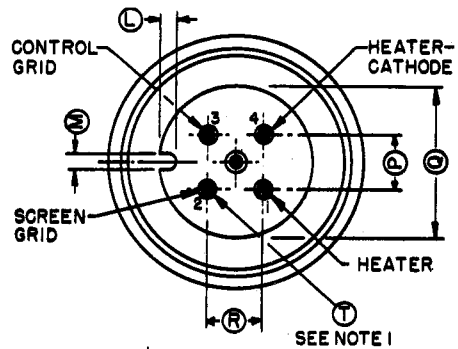
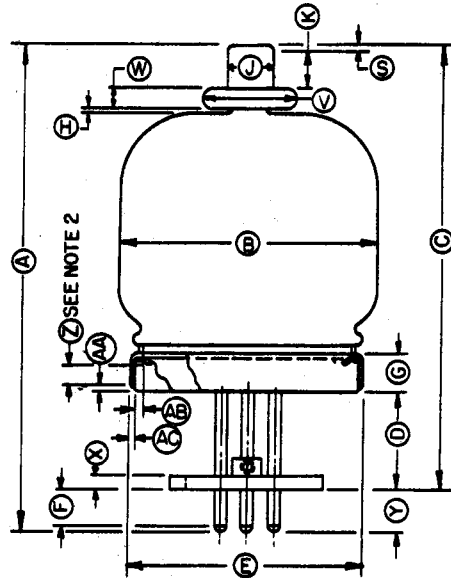

NOTE 1.
THE BASE SHALL BE CAPABLE OF ENTERING A GAGE $\frac{1}{4}$ THICK HAVING 4 HOLES $.214$ DIA LOCATED ON $\frac{1}{16}$ CENTERS AND A CENTER HOLE $.250$ DIA.

NOTE 2.
DEFINES CYLINDRICAL SURFACE AVAILABLE FOR CLAMPING WHICH MUST NOT BE DEFORMED BY ACTION OF CLAMPS.