

| | | |
|---|-----------------|--------------|
| Specification MOS(A)/CV2516 incorporating MII/E/1/546C Issue 2 dated 26-2-57 To be read in conjunction with K.1006 | <u>SECURITY</u> | |
| | Specification | Valve |
| | UNCLASSIFIED | UNCLASSIFIED |

→ indicates a change

| <p>TYPE OF VALVE - Triode, UHF</p> <p>CATHODE - Indirectly heated</p> <p>ENVELOPE - Copper-glass</p> <p>PROTOTYPE - 2C39A</p> | <p style="text-align: center;"><u>MARKING</u></p> <p style="text-align: center;">See K1001/4</p> <p style="text-align: center;"><u>ADDITIONAL MARKING</u></p> <p style="text-align: center;">2C39A</p> | | | | | | | | | | | | | | | | | | | | | | | | | | | | | | | | | | | | | | | | | | | | | | | | | | | | | | | | | | | | | | | | | | | | | | | | | | | | | | | | | | | | |
|---|--|-----------|------|-----------|----------------|-------------|-----------|----------------|----------------|----------------|------|-----------------|---------------------------|-----|------|--|----------------------|------|-----|--|---------------------------|-------|----|--|--------------------------------|--|--|--|--------------------|------|-----|--|----------------------|------|-----|--|------------------------|-----|-----|---|-------------------|-----|------|--|-----------------------|-----|-----|---|-------------------|------|------|--|---------------------------|-------|----|--|--|--|--|--|------------------------|------|-----|---|----------------------|------|-----|--|------------------------|-----|-----|---|-----------------------|-----|-----|--|-------------------|------|----|--|---------------------------|-------|----|--|---|
| <p style="text-align: center;"><u>RATING (Note G)</u></p> <table border="1" style="width: 100%; border-collapse: collapse;"> <thead> <tr> <th></th> <th></th> <th></th> <th style="text-align: center;">Note</th> </tr> </thead> <tbody> <tr> <td>Heater Voltage</td> <td>(V)</td> <td>6.3 ± 10%</td> <td>A</td> </tr> <tr> <td>Heater Current</td> <td>(A)</td> <td>1.05</td> <td></td> </tr> <tr> <td>Max Negative Grid Voltage</td> <td>(V)</td> <td>-150</td> <td></td> </tr> <tr> <td>Max Seal Temperature</td> <td>(°C)</td> <td>175</td> <td></td> </tr> <tr> <td>Cathode Conditioning Time</td> <td>(sec)</td> <td>60</td> <td></td> </tr> <tr> <td colspan="4"><u>Oscillator or Amplifier</u></td> </tr> <tr> <td>Max. Anode Voltage</td> <td>(kV)</td> <td>1.0</td> <td></td> </tr> <tr> <td>Max. Cathode Current</td> <td>(mA)</td> <td>125</td> <td></td> </tr> <tr> <td>Max. Anode Dissipation</td> <td>(W)</td> <td>100</td> <td>B</td> </tr> <tr> <td>Max. Grid Voltage</td> <td>(V)</td> <td>-150</td> <td></td> </tr> <tr> <td>Max. Grid Dissipation</td> <td>(W)</td> <td>2.0</td> <td>D</td> </tr> <tr> <td>Max. Grid Current</td> <td>(mA)</td> <td>50.0</td> <td></td> </tr> <tr> <td>Cathode Conditioning Time</td> <td>(sec)</td> <td>60</td> <td></td> </tr> <tr> <td colspan="4"><u>Anode Modulated Oscillator or Amplifier</u></td> </tr> <tr> <td>Max Peak Anode Voltage</td> <td>(kV)</td> <td>1.2</td> <td>E</td> </tr> <tr> <td>Max. Cathode Current</td> <td>(mA)</td> <td>100</td> <td></td> </tr> <tr> <td>Max. Anode Dissipation</td> <td>(W)</td> <td>100</td> <td>F</td> </tr> <tr> <td>Max. Grid Dissipation</td> <td>(W)</td> <td>2.0</td> <td></td> </tr> <tr> <td>Max. Grid Current</td> <td>(mA)</td> <td>50</td> <td></td> </tr> <tr> <td>Cathode Conditioning Time</td> <td>(sec)</td> <td>60</td> <td></td> </tr> </tbody> </table> | | | | Note | Heater Voltage | (V) | 6.3 ± 10% | A | Heater Current | (A) | 1.05 | | Max Negative Grid Voltage | (V) | -150 | | Max Seal Temperature | (°C) | 175 | | Cathode Conditioning Time | (sec) | 60 | | <u>Oscillator or Amplifier</u> | | | | Max. Anode Voltage | (kV) | 1.0 | | Max. Cathode Current | (mA) | 125 | | Max. Anode Dissipation | (W) | 100 | B | Max. Grid Voltage | (V) | -150 | | Max. Grid Dissipation | (W) | 2.0 | D | Max. Grid Current | (mA) | 50.0 | | Cathode Conditioning Time | (sec) | 60 | | <u>Anode Modulated Oscillator or Amplifier</u> | | | | Max Peak Anode Voltage | (kV) | 1.2 | E | Max. Cathode Current | (mA) | 100 | | Max. Anode Dissipation | (W) | 100 | F | Max. Grid Dissipation | (W) | 2.0 | | Max. Grid Current | (mA) | 50 | | Cathode Conditioning Time | (sec) | 60 | | <p style="text-align: center;"><u>DIMENSIONS AND CONNECTIONS</u></p> <p style="text-align: center;">See drawing on page 4</p> |
| | | | Note | | | | | | | | | | | | | | | | | | | | | | | | | | | | | | | | | | | | | | | | | | | | | | | | | | | | | | | | | | | | | | | | | | | | | | | | | | | | | | | | | | |
| Heater Voltage | (V) | 6.3 ± 10% | A | | | | | | | | | | | | | | | | | | | | | | | | | | | | | | | | | | | | | | | | | | | | | | | | | | | | | | | | | | | | | | | | | | | | | | | | | | | | | | | | | | |
| Heater Current | (A) | 1.05 | | | | | | | | | | | | | | | | | | | | | | | | | | | | | | | | | | | | | | | | | | | | | | | | | | | | | | | | | | | | | | | | | | | | | | | | | | | | | | | | | | | |
| Max Negative Grid Voltage | (V) | -150 | | | | | | | | | | | | | | | | | | | | | | | | | | | | | | | | | | | | | | | | | | | | | | | | | | | | | | | | | | | | | | | | | | | | | | | | | | | | | | | | | | | |
| Max Seal Temperature | (°C) | 175 | | | | | | | | | | | | | | | | | | | | | | | | | | | | | | | | | | | | | | | | | | | | | | | | | | | | | | | | | | | | | | | | | | | | | | | | | | | | | | | | | | | |
| Cathode Conditioning Time | (sec) | 60 | | | | | | | | | | | | | | | | | | | | | | | | | | | | | | | | | | | | | | | | | | | | | | | | | | | | | | | | | | | | | | | | | | | | | | | | | | | | | | | | | | | |
| <u>Oscillator or Amplifier</u> | | | | | | | | | | | | | | | | | | | | | | | | | | | | | | | | | | | | | | | | | | | | | | | | | | | | | | | | | | | | | | | | | | | | | | | | | | | | | | | | | | | | | |
| Max. Anode Voltage | (kV) | 1.0 | | | | | | | | | | | | | | | | | | | | | | | | | | | | | | | | | | | | | | | | | | | | | | | | | | | | | | | | | | | | | | | | | | | | | | | | | | | | | | | | | | | |
| Max. Cathode Current | (mA) | 125 | | | | | | | | | | | | | | | | | | | | | | | | | | | | | | | | | | | | | | | | | | | | | | | | | | | | | | | | | | | | | | | | | | | | | | | | | | | | | | | | | | | |
| Max. Anode Dissipation | (W) | 100 | B | | | | | | | | | | | | | | | | | | | | | | | | | | | | | | | | | | | | | | | | | | | | | | | | | | | | | | | | | | | | | | | | | | | | | | | | | | | | | | | | | | |
| Max. Grid Voltage | (V) | -150 | | | | | | | | | | | | | | | | | | | | | | | | | | | | | | | | | | | | | | | | | | | | | | | | | | | | | | | | | | | | | | | | | | | | | | | | | | | | | | | | | | | |
| Max. Grid Dissipation | (W) | 2.0 | D | | | | | | | | | | | | | | | | | | | | | | | | | | | | | | | | | | | | | | | | | | | | | | | | | | | | | | | | | | | | | | | | | | | | | | | | | | | | | | | | | | |
| Max. Grid Current | (mA) | 50.0 | | | | | | | | | | | | | | | | | | | | | | | | | | | | | | | | | | | | | | | | | | | | | | | | | | | | | | | | | | | | | | | | | | | | | | | | | | | | | | | | | | | |
| Cathode Conditioning Time | (sec) | 60 | | | | | | | | | | | | | | | | | | | | | | | | | | | | | | | | | | | | | | | | | | | | | | | | | | | | | | | | | | | | | | | | | | | | | | | | | | | | | | | | | | | |
| <u>Anode Modulated Oscillator or Amplifier</u> | | | | | | | | | | | | | | | | | | | | | | | | | | | | | | | | | | | | | | | | | | | | | | | | | | | | | | | | | | | | | | | | | | | | | | | | | | | | | | | | | | | | | |
| Max Peak Anode Voltage | (kV) | 1.2 | E | | | | | | | | | | | | | | | | | | | | | | | | | | | | | | | | | | | | | | | | | | | | | | | | | | | | | | | | | | | | | | | | | | | | | | | | | | | | | | | | | | |
| Max. Cathode Current | (mA) | 100 | | | | | | | | | | | | | | | | | | | | | | | | | | | | | | | | | | | | | | | | | | | | | | | | | | | | | | | | | | | | | | | | | | | | | | | | | | | | | | | | | | | |
| Max. Anode Dissipation | (W) | 100 | F | | | | | | | | | | | | | | | | | | | | | | | | | | | | | | | | | | | | | | | | | | | | | | | | | | | | | | | | | | | | | | | | | | | | | | | | | | | | | | | | | | |
| Max. Grid Dissipation | (W) | 2.0 | | | | | | | | | | | | | | | | | | | | | | | | | | | | | | | | | | | | | | | | | | | | | | | | | | | | | | | | | | | | | | | | | | | | | | | | | | | | | | | | | | | |
| Max. Grid Current | (mA) | 50 | | | | | | | | | | | | | | | | | | | | | | | | | | | | | | | | | | | | | | | | | | | | | | | | | | | | | | | | | | | | | | | | | | | | | | | | | | | | | | | | | | | |
| Cathode Conditioning Time | (sec) | 60 | | | | | | | | | | | | | | | | | | | | | | | | | | | | | | | | | | | | | | | | | | | | | | | | | | | | | | | | | | | | | | | | | | | | | | | | | | | | | | | | | | | |
| <u>NOTES</u> | | | | | | | | | | | | | | | | | | | | | | | | | | | | | | | | | | | | | | | | | | | | | | | | | | | | | | | | | | | | | | | | | | | | | | | | | | | | | | | | | | | | | |
| <p>A. The transit time heating effect of the cathode must be compensated by a reduction in heater voltage after dynamic operation of the valve has started. The back heating is a function of frequency, grid current and grid bias. For satisfactory life the heater voltage must be adjusted to the value indicated by chart below. The rated variation of ± 10% Vh will apply to the value selected on this chart. Conditions of operation are limited to those which indicate a heater voltage of 4.5 volts or more</p> <table style="margin-left: auto; margin-right: auto;"> <thead> <tr> <th style="text-align: center;">Mc/s</th> <th style="text-align: center;">Vh</th> </tr> </thead> <tbody> <tr> <td style="text-align: center;">up to 400</td> <td style="text-align: center;">6.3</td> </tr> <tr> <td style="text-align: center;">400 to 1000</td> <td style="text-align: center;">6.0</td> </tr> <tr> <td style="text-align: center;">1,000 to 1,500</td> <td style="text-align: center;">5.5</td> </tr> <tr> <td style="text-align: center;">1,500 to 2,000</td> <td style="text-align: center;">5.0</td> </tr> <tr> <td style="text-align: center;">2,000 and above</td> <td style="text-align: center;">4.5</td> </tr> </tbody> </table> <p>B. Up to 100 watts dissipation shall be allowable with forced air cooling sufficient to limit seal temperature to 175°C. Recommended air flow is 12.5 cubic ft/min., with cooling per drawing (157-JAN) under ambient conditions of 25°C and 14.7 lbs/sq.in., pressure.</p> <p>C. Sufficient conduction and/or convection cooling must be provided for the heater, cathode and grid seals to limit the maximum seal temperatures to the specified maximum of 175°C under all operating conditions.</p> <p>D. Maximum instantaneous peak grid voltage + 30 to -400V dc.</p> <p>E. 1200 volts is at the crest of the audio wave</p> <p>F. For 100% modulation</p> <p>G. All limiting values are absolute</p> | | Mc/s | Vh | up to 400 | 6.3 | 400 to 1000 | 6.0 | 1,000 to 1,500 | 5.5 | 1,500 to 2,000 | 5.0 | 2,000 and above | 4.5 | | | | | | | | | | | | | | | | | | | | | | | | | | | | | | | | | | | | | | | | | | | | | | | | | | | | | | | | | | | | | | | | | | | | | | | | |
| Mc/s | Vh | | | | | | | | | | | | | | | | | | | | | | | | | | | | | | | | | | | | | | | | | | | | | | | | | | | | | | | | | | | | | | | | | | | | | | | | | | | | | | | | | | | | |
| up to 400 | 6.3 | | | | | | | | | | | | | | | | | | | | | | | | | | | | | | | | | | | | | | | | | | | | | | | | | | | | | | | | | | | | | | | | | | | | | | | | | | | | | | | | | | | | |
| 400 to 1000 | 6.0 | | | | | | | | | | | | | | | | | | | | | | | | | | | | | | | | | | | | | | | | | | | | | | | | | | | | | | | | | | | | | | | | | | | | | | | | | | | | | | | | | | | | |
| 1,000 to 1,500 | 5.5 | | | | | | | | | | | | | | | | | | | | | | | | | | | | | | | | | | | | | | | | | | | | | | | | | | | | | | | | | | | | | | | | | | | | | | | | | | | | | | | | | | | | |
| 1,500 to 2,000 | 5.0 | | | | | | | | | | | | | | | | | | | | | | | | | | | | | | | | | | | | | | | | | | | | | | | | | | | | | | | | | | | | | | | | | | | | | | | | | | | | | | | | | | | | |
| 2,000 and above | 4.5 | | | | | | | | | | | | | | | | | | | | | | | | | | | | | | | | | | | | | | | | | | | | | | | | | | | | | | | | | | | | | | | | | | | | | | | | | | | | | | | | | | | | |

Z.13836.R.

CV2516

MIL-E-1/546C
14 May 1956
SUPERSEDING
MIL-E-1/546B
23 August 1955

INDIVIDUAL MILITARY SPECIFICATION SHEET

ELECTRON TUBE, TRIODE, UHF

JAN-2C39A

This specification sheet forms a part of the latest issue of Military Specification MIL-E-1.

Description: Triode, UHF

F₁=2500 Mc

| Ratings: | Ef | eb | Eb | Ebb | Ik | Pp | Ec | Seal Temp. | Pg | Rk | Ic | tk | Alt. |
|--------------------------------------|-------------------------------------|------|------|-----|------|-----|------|--------------------------------|-----|------|------|-----|--------|
| Absolute | V | v | Vdc | Vdc | mAde | W | Vdc | °C | W | ohms | mAde | sec | ft. |
| Maximum: | (Note 1) (Note 2) (Note 3) (Note 4) | | | | | | | | | | | | |
| Osc. or Ampl. | 6.3/10% | --- | 1000 | --- | 125 | 100 | -150 | 175 | 2 | --- | 50 | 60 | 10,000 |
| Plate Mod. Osc. or Ampl. (Note 5) | 6.3/10% | 1200 | --- | --- | 100 | 100 | -150 | 175 | 2 | --- | 50 | 60 | --- |
| Test Cond.: | 6.3 | --- | --- | 600 | --- | --- | --- | --- | --- | 30 | --- | 300 | --- |
| Dimensions: | Per Outline (Note 7) | | | | | | | **Cathode: Coated Unipotential | | | | | |

Pack in sealed water-vapor-proof bag. If opaque bag is used, the tube type number shall be stamped thereon.

For miscellaneous requirements see par. 3.3 of Inspection Instructions for Electron Tubes.

| <u>Ref.</u> | <u>Test</u> | <u>Conditions</u> | <u>Min.</u> | <u>Max.</u> |
|-------------|-----------------------------------|--|--------------------------------------|-------------|
| 3.1 | Qualification Approval: | Required for JAN Marking | | |
| 4.9.13.1.8 | Carton Drop: | (d) Package Group 1; Carton Size G; | | |
| 4.9.5.1 | *Torque: | Note 9 | | |
| 4.5 | Holding Period: | 10 days | | |
| 4.9.19.1 | *Low Frequency Vibration: | Ec/Ib=10mAde; Rp=10,000; Rk=0; Ebb=300 Vdc | Ep: --- | 100 mVac |
| 4.9.20.5 | **Shock Test: | Note 8; No Voltages hammer angle -16°; Y1, Y2, X2 | | |
| 4.10.8 | *Heater Current: | | If: .95 | 1.1A |
| 4.8 | *Insulation of Electrodes: | | Rgk: 10 --- Meg. Rgp: 25 --- Meg. | |
| 4.10.6.1 | $\frac{I}{T}$ Total Grid Current: | | Ic: --- | -10 uAde |
| 4.10.4.1 | Plate Current (1): | | Ib: 60.0 | 95.0 mAde |
| 4.10.4.1 | *Plate Current (2): | Ec/Ib=1.0 mAde | Ec: --- | -15 Vdc |
| 4.10.9 | Transconductance: | | Sm: 20,000 | 30,000 |

CV 2516

| Ref. | Test | Conditions | Min. | Max. |
|----------|-------------------------------------|---|------------------|----------|
| 4.10.1.5 | Pulsing Emission: | eb=ec=225v(max.); tp=3us(max.);prp=600 (max.);Note 10 | is: 6.0 | --- a |
| 4.10.6.6 | Grid Sparking: | Pg=3W;ec=30 v to -400v; Note 11 | | |
| 4.10.2.2 | Power Oscillation: | F=2460Mc(min.);Ebb=900Vdc; Po: 12 Ib=90mAdc;Ec/Max. Po; Ef=5.0V; Note 13 | | --- W |
| --- | *Tuning Range: | Po; F=2000 \angle 1Mc; Note 18 | F: 1960 | 2030 Mc |
| --- | **Frequency Drift: | Po; Note 14 | Δ Ic: --- | 10 % |
| | | | Δ Ib: --- | 10 % |
| | | | Δ F: --- | 3 Mc |
| 4.10.1.4 | *Direct-interelectrode capacitance: | Note 12 | Cgk: 5.60 | 7.60 uuf |
| | | | Cgp: 1.86 | 2.16 uuf |
| | | | Cpk: --- | .035 uuf |
| 4.11 | Life Test (1): | Group C; F=500Mc(min.); Ebb=800Vdc; Ib=80mAdc; Initial Po=27W(min.); Note 15 | t: 500 | --- hrs |
| 4.11.4 | Life Test End Point(1): | Life Test (1) | Po: 20 | --- W |
| 4.11 | Life Test (2): | Group D; F=2000 Mc(min.) Ebb=900 Vdc; Ib=80mAdc; Ec/Max. Po; Note 16 | t: 100 | --- hrs |
| 4.11.4 | Life Test End Point(2): | Life Test (2) | Po: 8 | --- W |

Note 1: The transit time heating effect of the cathode must be compensated by a reduction in heater voltage after dynamic operation of the tube has started. The back heating is a function of frequency, grid current, and grid bias. For satisfactory life the heater voltage must be adjusted to the value indicated by chart below. The rated variation of $\pm 10\%$ Ef will apply to the value selected on this chart. Conditions of operation are limited to those which indicate a heater voltage of 4.5 volts or more.

| Mc | Ef |
|----------------|-----|
| up to 400 | 6.3 |
| 400 to 1000 | 6.0 |
| 1000 to 1500 | 5.5 |
| 1500 to 2000 | 5.0 |
| 2000 and above | 4.5 |

Note 2: Up to 100 watts dissipation shall be allowable with forced-air cooling sufficient to limit seal temperature to 175°C. Recommended air flow is 12.5 cubic ft/min., with cowling per drawing (157-JAN), under ambient conditions of 25°C and 14.7 lbs/sq. in. pressure.

Note 3: Sufficient conduction and/or convection cooling must be provided for the heater, cathode, and grid seals to limit the maximum seal temperatures to the specified maximum of 175°C under all operating conditions.

Note 4: Max. instantaneous peak grid voltage $\angle 30$ to -400Vdc.

CV2516

- Note 5: 1200 volts is at the crest of the audio wave.
- Note 6: For 100% modulation.
- Note 7: With respect to paragraph 4.1.2 of MIL-E-1, the tests called for in the tube outline drawing shall be considered separately from the rest of the specification.
- Note 8: Test in jig made in accordance with JAN drawing No. 159-JAN.
- Note 9: (a) The Tube shall be held securely at the cathode connection. A force of five (5) pounds shall be applied to the heater cup without perceptible shock. This test may be made by applying the force at right angles to the inside of the cup at a point $7/64" \pm 1/64"$ from the cathode end of the tube. An approved equivalent method may be used. The heater cup shall not loosen or short on the cathode connection. This test shall be applied on all tubes before the holding period. This test shall revert to qualification approval test if the spaces between the heater cup and the cathode sleeve are completely filled with insulating material.
- (b) A torque of 15 in-lbs shall be applied between anode and cathode without shock on a design check basis.
- Note 10: Test conditions may be $I_s=6a$: and limit $=e_b-e_c=225v$ max.
- Note 11: Test to be made in accordance with the procedure specified and in the circuit (Figure 1) or an approved equivalent.
- Note 12: Measured in socket per drawing 158-JAN.
- Note 13: Test to be made in cavity per drawing 160-JAN. The cavity shall be connected to a standard load approved by a government laboratory, with a VSWR less than 1.15. The output coupling from the oscillator and grid resistor are to be adjusted for maximum power output.
- Note 14: The bias, tuning, or coupling shall not be adjusted during the test period. The maximum changes one minute after power output has reached maximum shall be within the limits specified. With $E_f=5.0$ volts and full power output, reduce E_f to 4.5 volts; allow oscillator to reach equilibrium operation and observe frequency, then increase E_f to 5.5 volts, allow to reach equilibrium operation and observe frequency.
- Note 15: Life test shall be run in cavity per drawing 160-JAN (probe feedback and probe output, coupling), or equivalent, as a self-excited oscillator.
- Note 16: Life test shall be run in a self-excited cavity oscillator with nominal efficiency of 15 per cent.
- Note 17: Drawings may be obtained upon request from Armed Services Electro Standards Agency, Attn: Armed Services Electron Tube Committee, Fort Monmouth, New Jersey.
- Note 18: Test in cavity per drawing 160-JAN. Calibrate the circuit by adjusting the plate cavity until the frequency of oscillation for maximum P_o is $2000Mc \pm 1Mc$ with a standard tube, selected for $C_{gp}=2.01 \pm .02$ uuf and C_{gk} within limits (standard tubes will be provided by services). An alternate test may be made at $2500 Mc \pm 1.0Mc$ with the same spread as shown for the 2000 Mc test. The plate cavity shall then be locked in place for test. The cathode cavity and coupling, may be adjusted during test for maximum P_o . An approved resonance test may be substituted for the above.
- Note 19: Reference specification shall be of the issue in effect on the date of invitation for bid.

CV2516

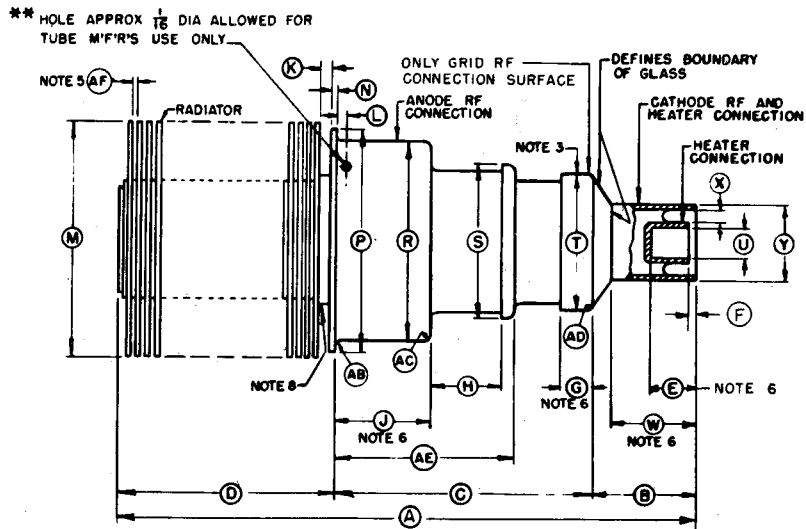

- *NOTE 1. THE ANODE, GRID, AND CATHODE CONNECTIONS SHALL BE CONCENTRIC WITH RESPECT TO EACH OTHER WITHIN .020 (TIR=.040)
- *NOTE 2. ECCENTRICITY BETWEEN THE HEATER AND THE CATHODE CONNECTOR SLEEVE SHALL NOT EXCEED .012".
- *NOTE 3. SOLDER SHALL NOT EXTEND BEYOND CYLINDRICAL SURFACE DEFINED BY DIMENSION (M)
- NOTE 4. INNER EDGE OF HEATER AND OUTER EDGE OF CATHODE RF CONNECTION SHALL BE FREE FROM BURRS AND SHARP EDGES.
- NOTE 5. DISTORTION OF FINS PERMISSIBLE PROVIDED DISTANCE BETWEEN ADJACENT FINS AT ANY POINT AROUND CIRCUMFERENCE IS NOT LESS THAN SPECIFIED.
- NOTE 6. PORTION AVAILABLE FOR CONTACT AREA MUST BE CLEAN AND SMOOTH.
- NOTE 7. SILVER PLATE 30 MSI OR GOLD PLATE 10 MSI ON ALL EXTERNAL METAL SURFACES. THIS TEST MAY BE LIMITED TO TWO (2) TUBES PER DAY WHEN IN CONTINUOUS PRODUCTION.
- NOTE 8. RADIATOR AND RADIATOR SUPPORT NEED NOT BE PLATED WHEN MADE OF COPPER OR APPROVED EQUIVALENT.
- NOTE 9. FIN AT OUTER END OF TUBE MUST HAVE SUFFICIENT STRENGTH TO WITHSTAND A DROP TEST FROM A SIX INCH HEIGHT WITHOUT DISTORTION AS JUDGED BY ABILITY TO MAINTAIN DIMENSION (AF) AND NOT LOOSENING. ON EVIDENCE OF SATISFACTORY QUALITY, TEST MAY BE REDUCED TO TWO (2) TUBES PER LOT, OR WHEN IN CONTINUOUS PRODUCTION TO TWO (2) PER DAY.
- NOTE 10. GOLD OR SILVER PLATING MAY BE OMITTED FROM THESE SURFACES IF THEY ARE COPPER PLATED MIN 0.0005 THICKNESS. CHECK TWO (2) TUBES PER DAY WHEN IN CONTINUOUS PRODUCTION.

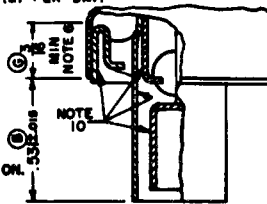

ALTERNATE CONSTRUCTION OF CATHODE END OF TUBE

| REF | DIMENSION | | |
|-----|-----------|---------|---------|
| | NOMINAL | MINIMUM | MAXIMUM |
| A | | | *2 3/4 |
| B | | *.516 | *.546 |
| C | | *1.289 | *1.329 |
| D | | *.736 | *.826 |
| E | | *.341 | |
| F | | | *.086 |
| G | | *.140 | |
| H | ** 3/16 | | |
| J | | *.459 | *.479 |
| K | | * 1/8 | |
| L | * 1/16 | | |
| M | | * 1/64 | * 1/64 |
| N | ** 1/32 | | |
| P | | *1.175 | *1.199 |
| R | | *1.021 | *1.039 |
| S | ** 5/32 | | |
| T | | *.652 | *.668 |
| U | | *.213 | *.223 |
| W | | *.400 | |
| X | | *.010 | |
| Y | | *.312 | *.328 |
| AB | | | * 3/32 |
| AC | | | * 3/32 |
| AD | | | * 1/32 |
| AE | | | ** 1/16 |
| AF | | * 1/8 | |

CV2516

GRID ARC TEST SET WIRING DIAGRAM

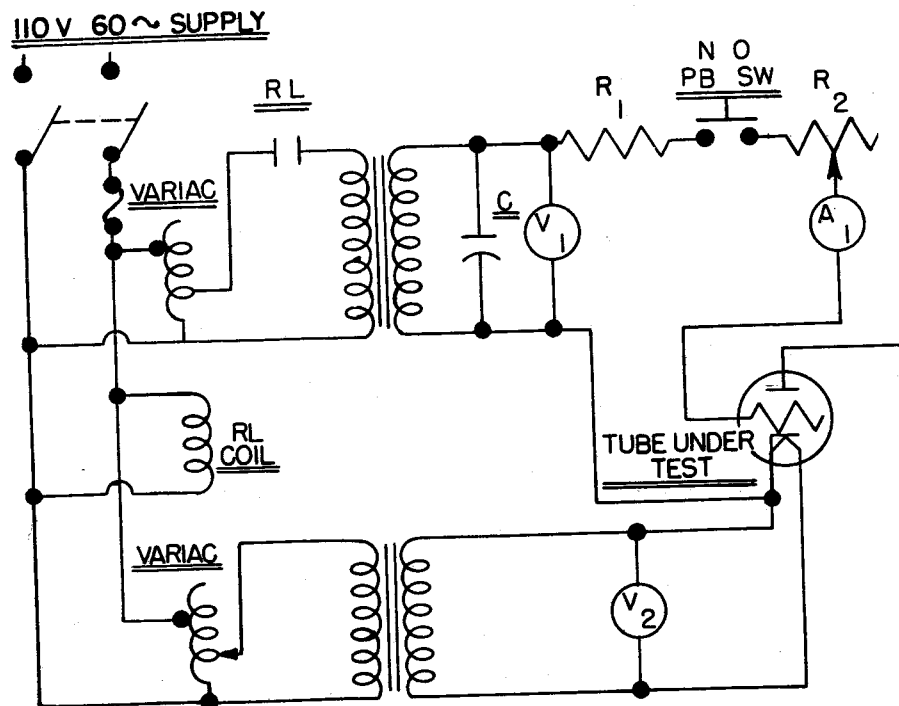

$C = 1 \text{ ufd, } 1000 \text{ volts}$
 $R_1 = 500 \text{ ohms, } 10 \text{ watts}$
 $R_2 = 1000 \text{ ohms, } 50 \text{ watts, variable}$
 $V_1 = 0 - 400 \text{ volts a.c.}$
 $V_2 = 0 - 10 \text{ volts a.c.}$
 $A_1 = 0 - 150 \text{ ma d.c.}$

PROCEDURE:

1. Tube is taken from pre-heat rack and placed in test socket.
2. Check heater voltage at 6.3 volts a.c. and grid voltage at 285 volts a.c.
3. Press the normally open push button switch, applying voltage between grid and cathode, adjusting R_2 if necessary to 100 ma d.c.
4. Press the button and hold for at least a 10-second interval. If the current drops to zero or fluctuates and continuous arcing is observed, reject the tube.

Figure 1

JAN-2C39A